

Data Projector

Operating Instructions

GB

VPL-PX32

WARNING

To prevent fire or shock hazard, do not expose the unit to rain or moisture.

To avoid electrical shock, do not open the cabinet. Refer servicing to qualified personnel only.

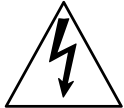

This symbol is intended to alert the user to the presence of uninsulated “dangerous voltage” within the product’s enclosure that may be of sufficient magnitude to constitute a risk of electric shock to persons.



This symbol is intended to alert the user to the presence of important operating and maintenance (servicing) instructions in the literature accompanying the appliance.

For the customers in the USA

This equipment has been tested and found to comply with the limits for a Class A digital device, pursuant to Part 15 of the FCC Rules. These limits are designed to provide reasonable protection against harmful interference when the equipment is operated in a commercial environment. This equipment generates, uses, and can radiate radio frequency energy and, if not installed and used in accordance with the instruction manual, may cause harmful interference to radio communications. Operation of this equipment in a residential area is likely to cause harmful interference in which case the user will be required to correct the interference at his own expense.

You are cautioned that any changes or modifications not expressly approved in this manual could void your authority to operate this equipment.



This label is located on the rear of the Remote Commander.



This label is located on the side of the Remote Commander.

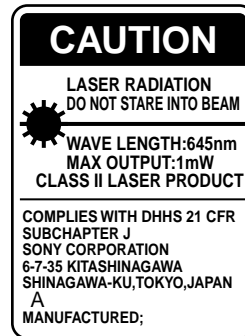

This label is located on the rear of the Remote Commander.

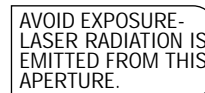

This label is located on the rear of the Remote Commander.

Laser light shines out of this window.



Caution

use of controls or adjustments or performance of procedures other than those specified herein may result in hazardous radiation exposure.

Notes

- Do not aim the laser at people or not look into the laser transmitter.
- When the Remote Commander causes malfunction, consult with qualified Sony personnel. We change the Remote Commander as new one according to the guarantee.

For the customers in Canada

This Class A digital apparatus complies with Canadian ICES-003.

For the customers in the United Kingdom

WARNING

THIS APPARATUS MUST BE EARTHED

IMPORTANT

The wires in this mains lead are coloured in accordance with the following code:

Green-and-Yellow: Earth
Blue: Neutral
Brown: Live

As the colours of the wires in the mains lead of this apparatus may not correspond with the coloured markings identifying the terminals in your plug proceed as follows:

The wire which is coloured green-and-yellow must be connected to the terminal in the plug which is marked by the letter E or by the safety earth symbol \perp or coloured green or green-and-yellow.

The wire which is coloured blue must be connected to the terminal which is marked with the letter N or coloured black.

The wire which is coloured brown must be connected to the terminal which is marked with the letter L or coloured red.

Voor de klanten in Nederland

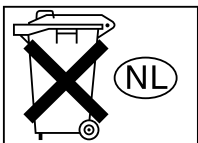

Gooi de batterij niet weg maar lever deze in als klein chemisch afval (KCA).

The socket-outlet should be installed near the equipment and be easily accessible.

Warning on power connection

Use a proper power cord for your local power supply.

	The United States, Canada		Continental Europe		UK, Ireland, Australia, New Zealand	Japan
Plug type	VM0233	290B	YP-12A	COX-07	— ¹⁾	YP332
Female end	VM0089	386A	YC-13B	COX-02	VM0310B	YC-13
Cord type	SJT	SJT	H05VV-F	H05VV-F	N13237/CO-228	VCTF
Rated Voltage & Current	10A/125V	10A/125V	10A/250V	10A/250V	10A/250V	7A/125V
Safety approval	UL/CSA	UL/CSA	VDE	VDE	VDE	DENAN

1) Use the correct plug for your country.

Table of Contents

Overview

Precautions	7 (GB)
Features	8 (GB)
Location and Function of Controls	9 (GB)
Front/Left Side	9 (GB)
Rear/Right Side/Bottom	9 (GB)
Control panel	11 (GB)
Connector panel	12 (GB)
Remote Commander	13 (GB)

Setting up and projecting

Installing the Projector	14 (GB)
Connecting	15 (GB)
Connecting with a Computer	15 (GB)
Connecting with a VCR/15k RGB/Component Equipment	18 (GB)
Selecting the Menu Language	19 (GB)
Projecting	19 (GB)
Effective tools for your presentation	21 (GB)

Adjustments and settings using the menu

Using the MENU	22 (GB)
The PICTURE CTRL Menu	22 (GB)
The INPUT SETTING Menu	24 (GB)
The SET SETTING Menu	26 (GB)
The INSTALL SETTING Menu	27 (GB)

Installation

Installation Examples	28 (GB)
Floor Installation	28 (GB)
Ceiling Installation	29 (GB)
Notes for Installation	30 (GB)
Unsuitable Installation	30 (GB)
Unsuitable Conditions for Use	30 (GB)

Maintenance

Maintenance	32 (GB)
Replacing the Lamp	32 (GB)
Cleaning the Air Filter	33 (GB)
Troubleshooting	34 (GB)

Other

Specifications	36 (GB)
Index	42 (GB)

Precautions

On safety

- Check that the operating voltage of your unit is identical with the voltage of your local power supply.
- Should any liquid or solid object fall into the cabinet, unplug the unit and have it checked by qualified personnel before operating it further.
- Unplug the unit from the wall outlet if it is not to be used for several days.
- To disconnect the cord, pull it out by the plug. Never pull the cord itself.
- The wall outlet should be near the unit and easily accessible.
- The unit is not disconnected to the AC power source (mains) as long as it is connected to the wall outlet, even if the unit itself has been turned off.
- Do not look into the lens while the lamp is on.
- Do not aim the laser at people or not look into the laser transmitter.
- Do not place your hand or objects near the ventilation holes — the air coming out is hot.
- Be careful not to catch your fingers by the adjuster when you lift up the projector. Do not push hard on the top of the projector with the adjuster out.

On illumination

- To obtain the best picture, the front of the screen should not be exposed to direct lighting or sunlight.
- Ceiling-mounted spot lighting is recommended. Use a cover over fluorescent lamps to avoid lowering the contrast ratio.
- Cover any windows that face the screen with opaque draperies.
- It is desirable to install the projector in a room where floor and walls are not of light-reflecting material. If the floor and walls are of reflecting material, it is recommended that the carpet and wall paper be changed to a dark color.

On preventing internal heat build-up

After you turn off the power with the I / ⏻ key on the Remote Commander or on the control panel, do not disconnect the unit from the wall outlet while the cooling fan is still running.

Caution

The projector is equipped with ventilation holes (intake) on the bottom and ventilation holes (exhaust) on rear. Do not block or place anything near these holes, or internal heat build-up may occur, causing picture degradation or damage to the projector.

On cleaning

- To keep the cabinet looking new, periodically clean it with a soft cloth. Stubborn stains may be removed with a cloth lightly dampened with a mild detergent solution. Never use strong solvents, such as thinner, benzene, or abrasive cleansers, since these will damage the cabinet.
- Avoid touching the lens. To remove dust on the lens, use a soft dry cloth. Do not use a damp cloth, detergent solution, or thinner.
- Clean the filter at regular intervals every 300 hours.

On repacking

- Save the original shipping carton and packing material; they will come in handy if you ever have to ship your unit. For maximum protection, repack your unit as it was originally packed at the factory.

On data projector

The data projector is manufactured using high-precision technology. You may, however, see tiny black points and/or bright points (red, blue, or green) that continuously appear on the data projector. This is a normal result of the manufacturing process and does not indicate a malfunction.

Features

High brightness, high picture quality

- **High brightness**

The high aperture ratio LCD panel with a microlens and the 200 W UHP lamp allow high brightness (light output 3000 ANSI lumen) and excellent uniformity on the picture.

- **High resolution**

By adopting three 1.3-inch, approximately 790,000-pixels XGA panels, this projector can project sharp picture with the resolutions of 1024 × 768 pixels for RGB input and 750 horizontal TV lines for video input.

- **High picture performance**

This projector utilizes 3D Digital Gamma correction for good picture uniformity. And the internal RGB enhancer provides sharper RGB images.

Simple setup

- **Sony original high performance APA (Auto Pixel Alignment) function**

You can get the clearest picture automatically by simply pressing the APA key when the signal is input from a computer.

- **Simple setup with external equipment**

This projector has 43 kinds of preset data for input signals. You can get a suitable picture by connecting an equipment with supplied cable and pressing the APA key.

- **USB, Digital RGB and 5BNC connectors**

USB equipment (e.g., USB mouse) allows you to expand your system. The Digital RGB connector allows you to connect the projector to a Digital RGB equipment. The 5BNC input connector allows you to connect the projector to a workstation output high-resolution signals and to connect the projector to a computer from a long distance.

Easy presentation

- **Remote Commander with mouse control and laser pointer functions**

With the built-in mouse receiver, you can operate a computer with the Remote Commander. For presentations, you can use the laser pointer built into the Remote Commander.

- **Digital ZOOM and HELP keys on the Remote Commander**

The Digital ZOOM allows you to enhance your presentation by zooming in on the image. The HELP key will be helpful if you encounter a problem during operation.

- **High portability**

This projector is compact-7.2kg (15lb 14oz), portable size. With such a feature, a carrying handle contributes to a convenient carrying, and you can carry it everywhere you want.

Multi scan compatibility

- **Scan converter built-in**

This projector has a built-in scan converter which converts the input signal within 1024 × 768 pixels.

- **Accept various input signals**

This projector accepts video signals of the composite, S video, and component as well as the 15k RGB, VGA¹⁾, SVGA¹⁾, XGA¹⁾ and SXGA¹⁾ signals, which all can be displayed.

- **Compatible with six color systems**

NTSC^{3,58}, PAL, SECAM, NTSC^{4,43²⁾}, PAL-M or PAL-N color system can be selected automatically or manually.

Other functions

Plug & Play

This projector complies with DDC1 and DDC2B. (DDC1 and DDC2B are the Display Data Channel (DDCTM)³⁾ standard in the VESA standard.)

When connecting a DDC1 host system, the projector synchronizes with V.CLK that follows the VESA standard and outputs EDID (Extended Display Identification Data) to the data line.

When connecting a DDC2B host system, the projector automatically switches to the appropriate communication mode.

1) VGA, SVGA, XGA and SXGA are registered trademarks of the International Business Machines Corporation, U.S.A.

2) NTSC^{4,43} is the color system used when playing back a video recorded on NTSC on an NTSC^{4,43} system VCR.

3) DDCTM is a registered trademark of the Video Electronics Standard Association.

Location and Function of Controls

Front/Left Side

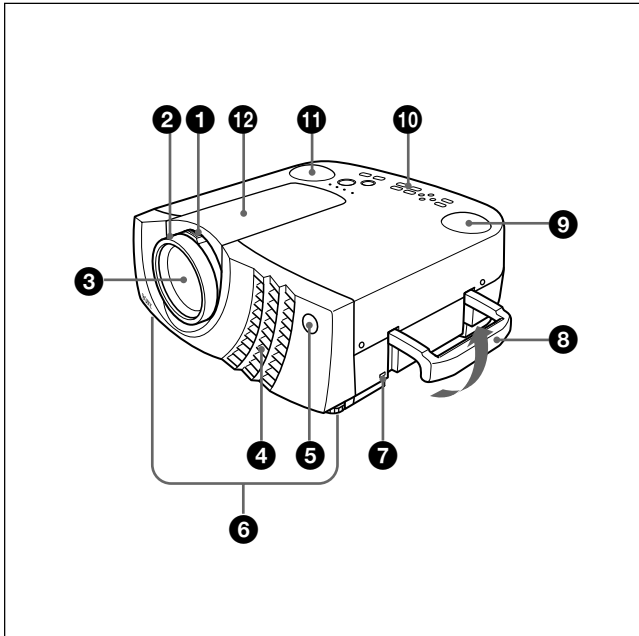

Rear/Right Side/Bottom

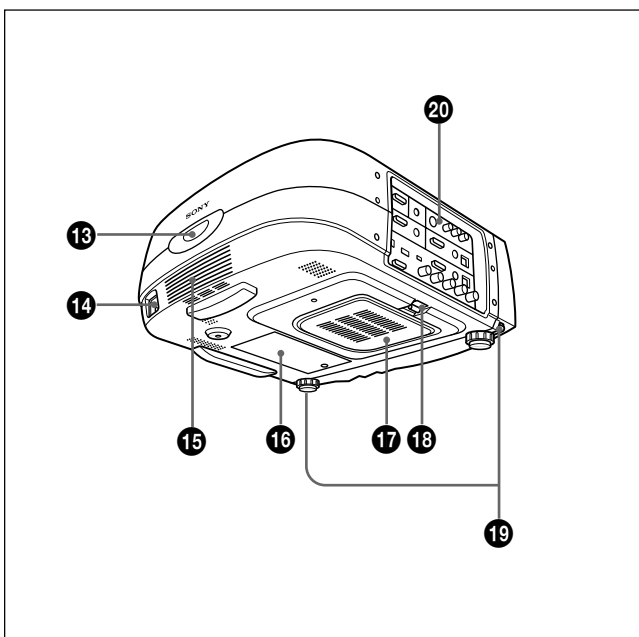

1 Zoom ring
Adjusts the size of the picture.

2 Focus ring
Adjusts the picture focus.

3 Lens
Open the lens cap before projection.

4 Ventilation holes (exhaust)

5 Front remote control detector (SIRCS receiver)

6 Adjuster
When a picture is projected on the out of the screen, adjust the picture using this adjuster.
For details on how to use the adjusters, see "How to use the adjuster" on page 10 (GB).

7 Security lock
Connects to an optional security cable (made by Kensington)¹⁾.
Home page address:
<http://www.kensington.com/>

8 Carrying handle
Pull up the handle from the projector for carrying.

9 Left speaker

10 Control panel
For details, see "Control panel" on page 11 (GB).

11 Right speaker

12 Lens hood

13 Rear remote control detector (SIRCS receiver)

14 AC IN socket
Connects the supplied AC power cord.

15 Rear speaker

16 Lamp cover

17 Ventilation holes (intake)/air filter cover

Notes

- Do not place anything near the ventilation holes as it may cause internal heat build-up.
- Do not place your hand or objects near the ventilation holes — the air coming out is hot.

1) Kensington and MicroSaver are registered trademarks of Kensington Technology Group.

18 Air filter cover button

Used to remove the air filter cover.

For details, see “Cleaning the Air Filter” on page 33 (GB).

Note

Clean the air filter every 300 hours to ensure optimal performance.

19 Adjuster buttons

20 Connector panel

For details, see page 12 (GB).

How to use the adjuster

To adjust the height

Adjust the height of the projector as follows:

- 1** Lift the projector and press the adjuster buttons. The adjusters will extend from the projector.

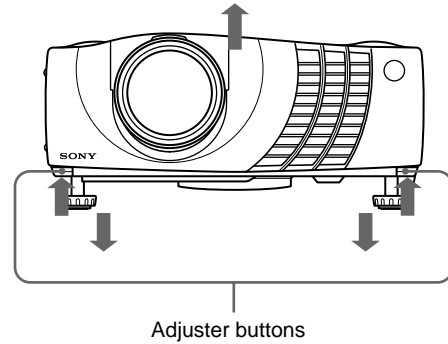

- 2** While pressing the buttons, lower the projector. Then, release the buttons. The adjusters will lock, then the height of the projector will be fixed. For fine adjustment, turn the adjusters to the right and the left.

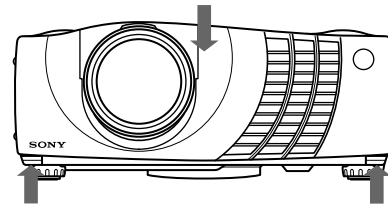

Notes

- Be careful not to let the projector down on your fingers.
- Do not push hard on the top of the projector with the adjusters out.

Control panel

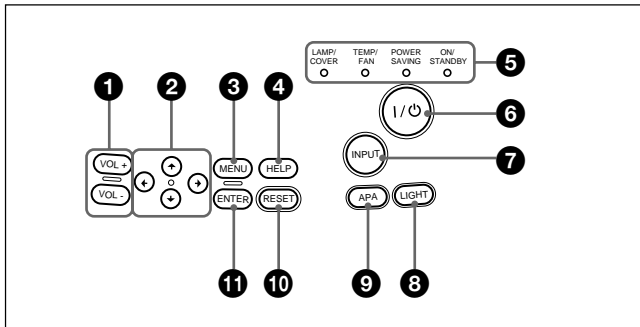

1 VOL +/- keys

Adjust the volume of the built-in speakers and output level of the AUDIO jack.

- + : Increases the volume.
- : Decreases the volume.

2 Arrow keys (↑/↓/←/→)

Used to select the menu or to make various adjustments.

3 MENU key

Displays the on-screen menu. Press again to clear the menu.

4 HELP key

If you need help information during an operation, press this key to display help messages. The Help menu lists error recoveries depending on problem type.

5 Indicators

LAMP/COVER: Lights up or flashes under the following conditions:

- Lights up when the lamp has reached the end of its life or becomes a high temperature.
- Flashes when the lamp cover or air filter cover is not secured firmly.

TEMP (Temperature)/FAN: Lights up or flashes under the following conditions:

- Lights up when temperature inside the projector becomes unusually high.
- Flashes when the fan is broken.

POWER SAVING: Lights up when the projector is in the power saving mode. When POWER SAVING in the SET SETTING menu is set to ON, the projector goes into the power saving mode if no signal is input for 10 minutes. Although the lamp goes out, the cooling fan keeps running. In the power saving mode, any key does not function for the first 40 seconds. The power saving mode is canceled when a signal is input or any key is pressed.

ON/STANDBY: Lights up or flashes under the following conditions:

- Lights in red when the AC power cord is plugged into the wall outlet. Once in the standby mode, you can turn on the projector with the I / ⏻ key.

- Lights in green when the power is turned on.
- Flashes in green while the cooling fan runs after turning off the power with the I / ⏻ key. The fan runs for about 120 seconds after turning off the power. The ON/STANDBY indicator flashes quickly for the first 40 seconds. During this time, you cannot turn the power back on with the I / ⏻ key.

For details on the LAMP/COVER and the TEMP/FAN indicators, see page 35 (GB).

6 I / ⏻ (on / standby) key

Turns on and off the projector when the projector is in the standby mode. The ON/STANDBY indicator lights in green when the power is turned on.

When turning off the power, press the I / ⏻ key twice following the message on the screen, or press and hold the key for about one second.

For details on steps for turning off the power, see “To turn off the power” on page 21 (GB).

7 INPUT key

Selects the input signal. Each time you press the key, the input signal switches as follows:

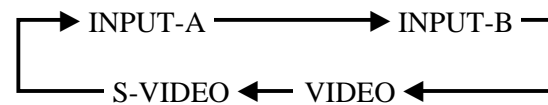

The audio signals are common to the VIDEO and S-VIDEO.

8 LIGHT key

If you press this key while the power is on, the keys on the control panel will be displayed in orange. Press this key to turn off the light.

9 APA (Auto Pixel Alignment) key

Adjusts a picture to be projected clearest automatically while a signal from the computer is input. Adjust the shift (up/down and left/right) at the same time automatically.

Note

Press the APA key when the full image is displayed on the screen. If there are black edges around the image, the APA function will not function properly and the image may extend beyond the screen.

10 RESET key

Resets the value of an item back to its factory preset value. This key functions when the menu or a setting item is displayed on the screen.

11 ENTER key

Enters the settings of items in the menu system.

Connector panel

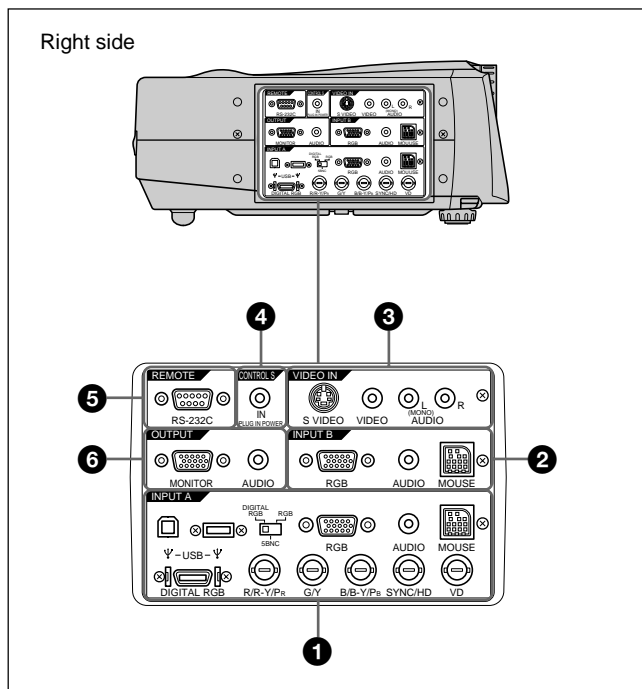

1 INPUT A connectors

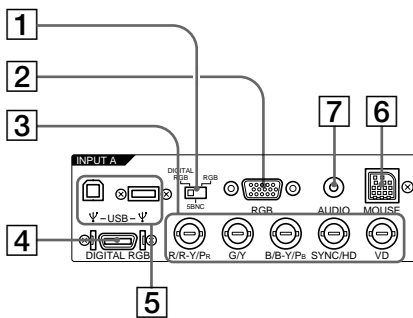

1 DIGITAL RGB/5BNC/RGB switch: Selects DIGITAL RGB, 5BNC or RGB on INPUT A connectors. Select the appropriate position depending on the input signal.

DIGITAL RGB: Signal input from DIGITAL RGB connector.

5BNC: Signal input from the 5BNC connector.

RGB: Signal input from the RGB connector.

2 RGB input connector (HD D-sub 15-pin, female): Connects to the monitor output on a computer using the supplied cable. This connector only accepts signals from a computer.

3 5BNC input connectors (R/R-Y/Pr, G/Y, B/B-Y/Pb, SYNC/HD, VD connectors) (BNC type): Connect to a high-resolution computer or VCR where signals are transmitted long distances; for example, when the projector has been hung from the ceiling.

According to the connected equipment, computer, component (R-Y/Y/B-Y), HDTV or DTV (DTV GBR, DTV YPbPr) signal is selected.

4 DIGITAL RGB input connector (DFP 20-pin, TMDS): Connects to a digital RGB output connector on external equipment.

5 USB connector: Connects your computer or USB equipment.

A plug: (Right, for downstream, 4-pin):

Connects to USB equipment.

B plug: (Left, for upstream, 4-pin): Connects to a computer. If you connect the projector and a computer, the projector automatically assumes that a USB mouse is connected; this allows you to control the mouse from the Remote Commander.

6 MOUSE (13-pin) connector: Connects to the mouse port on a computer to control the mouse function using the supplied mouse cable.

7 AUDIO (stereo mini-jack) jack: Connects to the audio output on a computer.

2 INPUT B connectors

Connect to external equipment such as a computer. You can control the mouse signal with the Remote Commander.

RGB input (HD D-sub 15-pin, female): Connects to the monitor output on a computer using the supplied cable. This connector only accepts signals from a computer.

AUDIO (stereo mini-jack): Connects to the audio output on a computer.

MOUSE (13-pin): Connects to the mouse port on a computer to control the mouse function using the supplied mouse cable.

3 VIDEO IN jacks

Connect to external video equipment such as a VCR.

S VIDEO (mini DIN 4-pin): Connects to the S video output (Y/C video output) on video equipment.

VIDEO (phono type): Connects to the composite video output.

AUDIO input L (MONO)/R (phono type): Connect to the audio output of equipment. For stereo equipment, use both the L and R jacks; for monaural equipment, use the L (MONO) jack only.

The audio signals are common to the VIDEO and S VIDEO.

4 CONTROL S IN/PLUG IN POWER (DC 5V output) jack

Connects to the control S out jacks of the Sony equipment. Connects to the CONTROL S OUT jack on the supplied Remote Commander when using it as a wired Remote Commander. In this case, you do not need to install the batteries in the Remote Commander, since the power is supplied from this jack.

5 RS-232C connector (D-sub 9-pin, female)

Connects to a computer to operate the projector from the computer.

6 OUTPUT connectors

MONITOR (HD D-sub 15-pin, female): Connects to the video input connector on the monitor.

Outputs signals from the selected channel in the INPUT A (RGB or 5BNC) or INPUT B (RGB) connector. This connector does not output any signals from the DIGITAL RGB connector.

AUDIO (phono type): Connects to external active speakers.

The volume of the speakers can be controlled by the VOLUME +/- keys on the Remote Commander or the VOL +/- keys on the control panel.

Remote Commander

The keys which have the same names as on the control panel function identically.

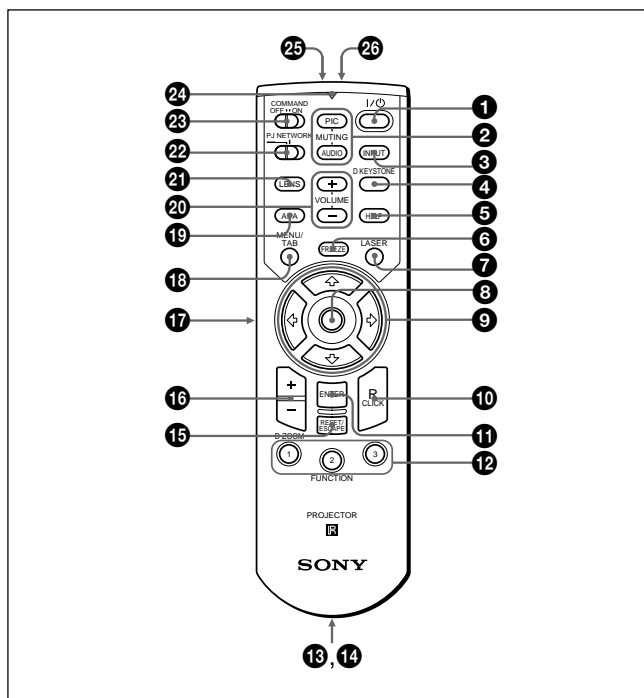
**Note**

There may be no LENS key in your Remote Commander. Moreover, the position of the HELP key and the FREEZE key on your Remote Commander may differ.

Notes on laser beam

- Do not look into the laser transmitter.
- Do not aim the laser at people.

1 I / \odot key**2 MUTING keys**

Cut off the picture and sound.

PIC: Cuts off the picture. Press again to restore the picture.

AUDIO: Cuts off the sound from speakers and AUDIO jack. Press again or press the VOLUME + key to restore the sound.

3 INPUT key**4 D KEYSTONE key**

Corrects the trapezoidal distortion caused by the projection angle. Use the arrow keys ($\uparrow/\downarrow/\leftarrow/\rightarrow$) to display the image as a rectangle.

5 HELP key

If you need help information during an operation, press this key to display help messages.

6 FREEZE key

This key does not work in the unit.

7 Laser transmitter**8 Joy stick**

Functions as a mouse of a computer connected to the unit.

9 Arrow keys ($\uparrow/\downarrow/\leftarrow/\rightarrow$)**10 R CLICK key**

Functions as a right button on a mouse of a computer connected to the unit.

11 ENTER key**12 FUNCTION 1/2/3 keys**

This key does not work in the unit.

13 Strap holder

Attaches the supplied strap.

14 CONTROL S OUT jack (stereo minijack)

Connects to the CONTROL S IN jack on the projector with the connecting cable (not supplied) when using the Remote Commander as a wired one. In this case, you do not need to install the batteries since the power is supplied via the CONTROL S IN jack on the projector.

15 RESET/ESCAPE key

Functions as a RESET key.

16 D ZOOM +/- key

Enlarges the image at a desired location on the screen.

+: Pressing the + key once displays the icon. This icon indicates the point you want to enlarge. Use an arrow key ($\uparrow/\downarrow/\leftarrow/\rightarrow$) to move the icon to the point to be enlarged. Press the + key repeatedly until the image is enlarged to your requirements.

-: Pressing the - key reduces an image that has been enlarged with the D ZOOM + key.

17 L CLICK key

Functions as a left button on a mouse of a computer connected to the unit.

18 MENU/TAB key

Functions as a MENU key.

19 APA (Auto Pixel Alignment) key

20 VOLUME +/- keys

21 LEMS key

This key does not work in the unit.

22 PJ/NETWORK (Projector/Network) selector switch

Set this switch to PJ always.

23 COMMAND ON/OFF switch

When this switch is set to OFF, no key on the Remote Commander function. This saves the battery power.

24 Transmission indicator

Lights up when you press a key on the Remote Commander.

This indicator does not light up when you use the laser pointer.

25 Infrared transmitter

26 LASER key

Emits laser beam from the laser transmitter when you press this key.

Battery installation

- 1 Push and slide to open the lid, then install the two size AA (R6) batteries (supplied) with the correct polarity.

Slide while pressing down on the lid.

Be sure to install the battery from the ⊖ side.

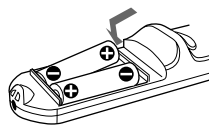
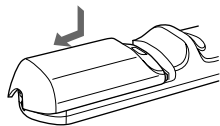

- 2 Replace the lid.

Notes on batteries

- Make sure that the battery orientation is correct when inserting batteries.
- Do not mix an old battery with a new one, or different types of batteries.
- If you will not use the Remote Commander for a long time, remove the batteries to avoid damage from battery leakage. If batteries have leaked, remove them, wipe the battery compartment dry and replace the batteries with new ones.

Notes on Remote Commander operation

- Make sure that there is nothing to obstruct the infrared beam between the Remote Commander and the remote control detector on the projector.
- The operation range is limited. The shorter the distance between the Remote Commander and the projector is, the wider the angle within which the commander can control the projector.

Installing the Projector

This section describes the installation arrangements for installing the projector.

Horizontal center of the screen

The distance between the lens and the screen varies depending on the size of the screen. Use the following table as a guide.

Distance between the screen and the center of the lens

Unit: m (feet)

Screen size (inches)	40	60	80	100	120	150	200	300
Minimum Distance	1.5 (4.9)	2.3 (7.5)	3.1 (10.0)	3.9 (12.6)	4.6 (15.2)	5.8 (19.1)	7.8 (25.5)	11.7 (38.4)
Maximum Distance	1.8 (6.0)	2.8 (9.1)	3.7 (12.3)	4.7 (15.4)	5.7 (18.6)	7.1 (23.3)	9.5 (31.2)	14.3 (46.9)

Connecting

Connecting with a Computer

This section describes how to connect the projector to a computer.

You can control the projector from your computer by using USB equipment. For details, see “Using USB equipment (e.g., USB mouse)”.

Also refer to the instruction manual of equipment to be connected.

Notes

- This unit accepts the VGA, SVGA, XGA or SXGA signals. However, we recommend you to set the output signal of your computer to the XGA.
- If you set your computer, such as a notebook type IBM PC/AT¹⁾ compatible, to output the signal to both the display of your computer and the external monitor, the picture of the external monitor may not appear properly. In such cases, set the output mode of your computer to output the signal to only the external monitor.

For details, refer to the operating instructions supplied with your computer.

- The RGB input connectors of the INPUT A/B and DIGITAL RGB connector of the INPUT A comply with the VESA DDC2B. If your computer or graphics board is compatible with DDC, turn on the power of the equipment as follows:
 - 1 Connect the projector to the computer with the HD D-sub 15-pin cable.
 - 2 Turn on the power of the projector.
 - 3 Boot up the computer.

When making connections, be sure to:

- turn off all equipment before making any connections.
- use the proper cables for each connection.
- insert the plugs of the cables properly; plugs that are not fully inserted often generate noise. When pulling out a cable, be sure to pull it out from the plug, not the cable itself.

Notes

- Connect all the connecting cables to the INPUT A connector when you input a signal from the INPUT A connector.
Connect all the cables to the INPUT B connector when you input a signal from the INPUT B connector as well.
- Supplied mouse cables may not work properly according to your computer.

1) IBM and PC/AT are a trademark and a registered trademark of International Business Machines Corporation, U.S.A.

When connecting with an IBM PC/AT compatible computer

When connecting with a Macintosh¹⁾ computer

To connect a Macintosh computer equipped with video output connector of a type having two rows of pins, use a commercially available plug adaptor. In this case, however, you can not control the mouse of the computer by the Remote Commander.

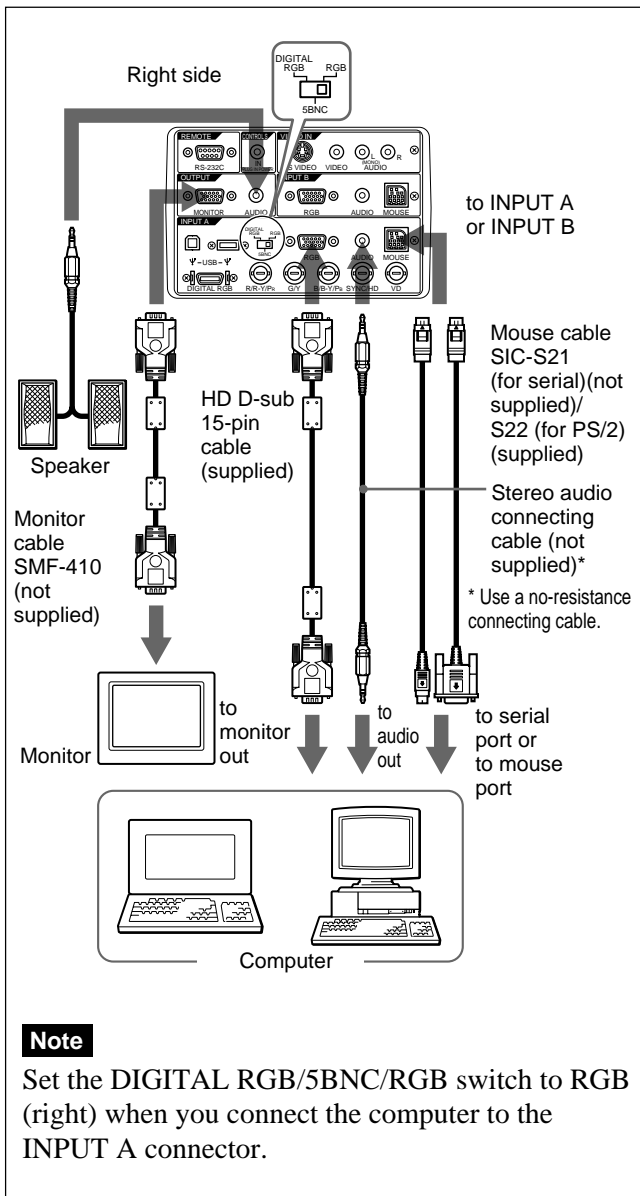

1) Macintosh is a registered trademark of Apple Computer, Inc.

Using the DIGITAL RGB (TMDS) connector

Connect the computer to the DIGITAL RGB (TMDS) connector on the connector panel.

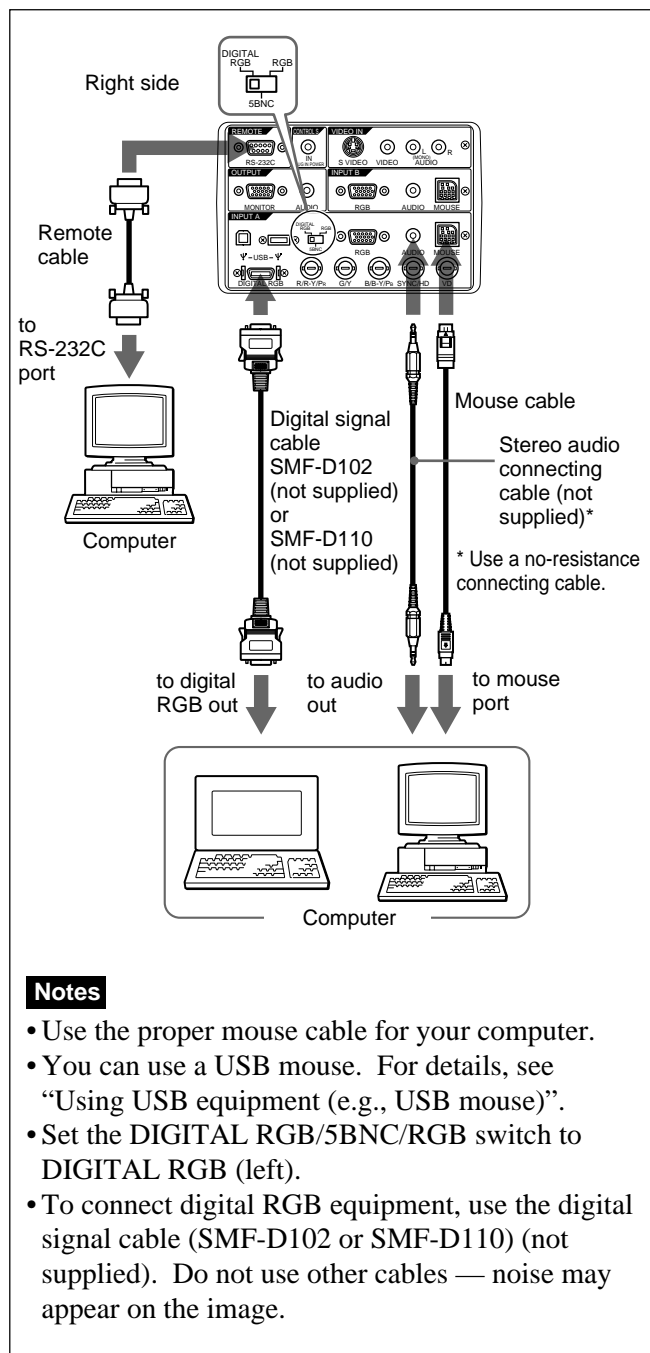

Note
If you use the DIGITAL RGB (TMDS) connector, the MONITOR connector will not output image signals.

Using USB equipment (e.g., USB mouse)

Connect the USB equipment to the USB connector on the connector panel.

You can connect your computer to the projector via the RGB connector, 5BNC connector or DIGITAL RGB connector. (The example below uses the RGB connector.)

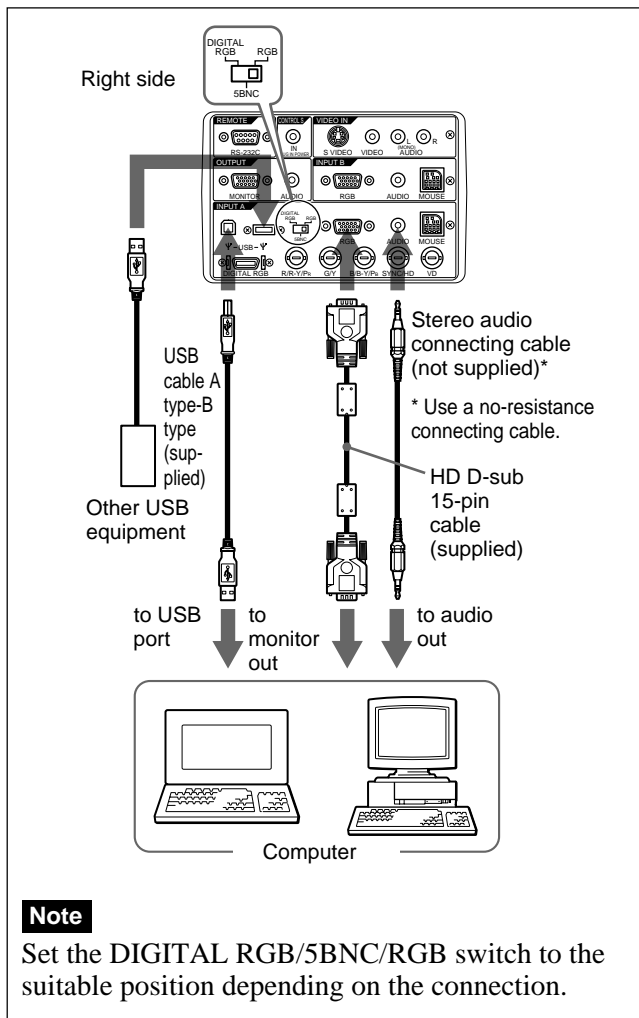

On the USB function

When connecting the projector to a computer by using the USB cable for the first time, the computer recognizes the following devices automatically.

- 1 USB hub (general use)
- 2 USB human interface device (wireless mouse function)
- 3 USB human interface device (projector control function)

The computer also recognizes the device connected to the downstream connector on the projector.

Recommended operating environment

When you use the USB function, connect your computer as illustrated above. The USB function can be used on a computer loaded with Windows¹⁾ 98, Windows 98 SE or Windows 2000 preinstall models.

1) Windows is registered trademark of Microsoft Corporation (U.S.A. and other countries).

Notes

- As the projector recognizes the USB mouse when the computer is connected to the USB connector, do not connect anything to the MOUSE connector.
- Your computer may not start correctly when connected to the projector via the USB cable. In this case, disconnect the USB cable, restart the computer, then connect the computer to the projector using the USB cable.
- This projector is not guaranteed for suspend, standby mode. When you use the projector in suspend, standby mode, disconnect the projector from the USB port on the computer.
- Operations are not guaranteed for all the recommended computer environments.

Connecting with a VCR/15k RGB/Component Equipment

This section describes how to connect the projector with a VCR, external active speakers, and 15k RGB/component equipment. Also refer to the instruction manuals of the equipment to be connected.

When making connections, be sure to:

- turn off all equipment before making any connections.
- use the proper cables for each connection.
- insert the plugs of the cables properly; plugs that are not fully inserted often generate noise. When pulling out a cable, be sure to pull it out from the plug, not the cable itself.

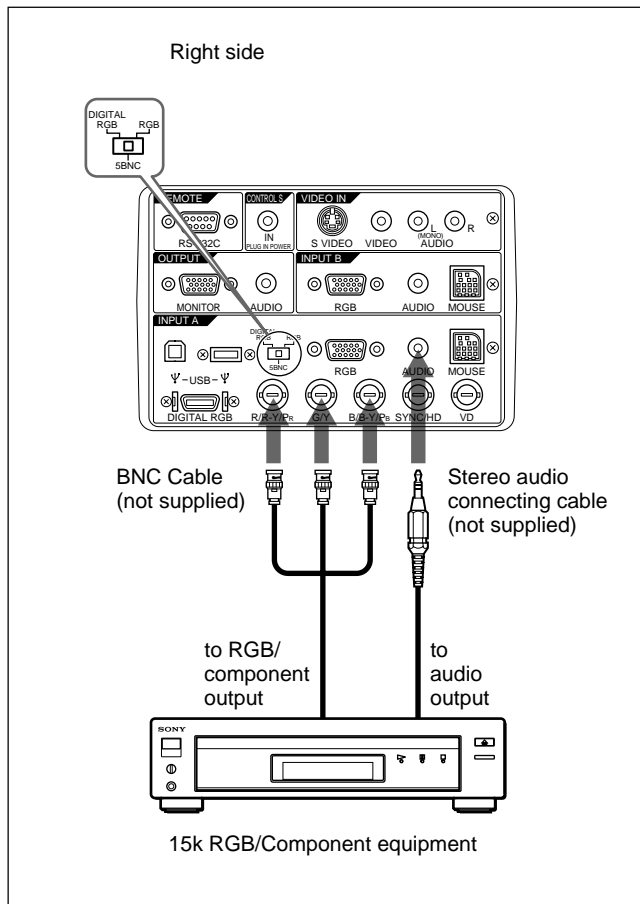

Notes

- Set the aspect ratio using ASPECT in the INPUT SETTING menu according to the input signal.
- To connect a 15k RGB/Component equipment, select the COMPUTER/COMPONENT/DTV YPbPr/DTV GBR in the INPUT-A in the SET SETTING menu according to the input signal.
- Use the composite sync signal when you input the external sync signal from 15k RGB/component equipment.

Connecting to a HDTV 1035/60i

Since the screen ratio of a high definition image is 16:9 and 576 lines are displayed in the vertical direction, the image displayed is not a high-definition image.

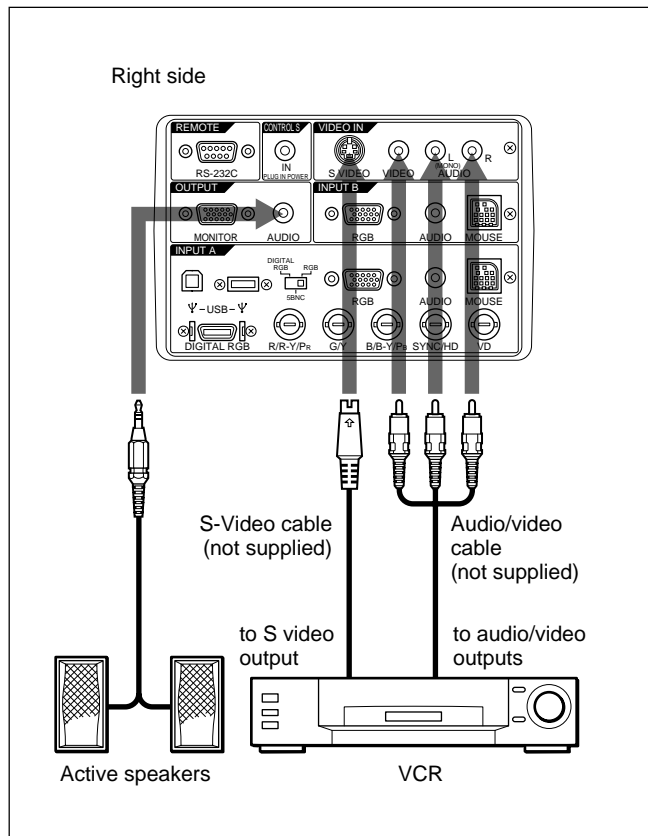

Selecting the Menu Language

You can select the language for displaying in the menu and other on screen displays. The factory setting is ENGLISH.

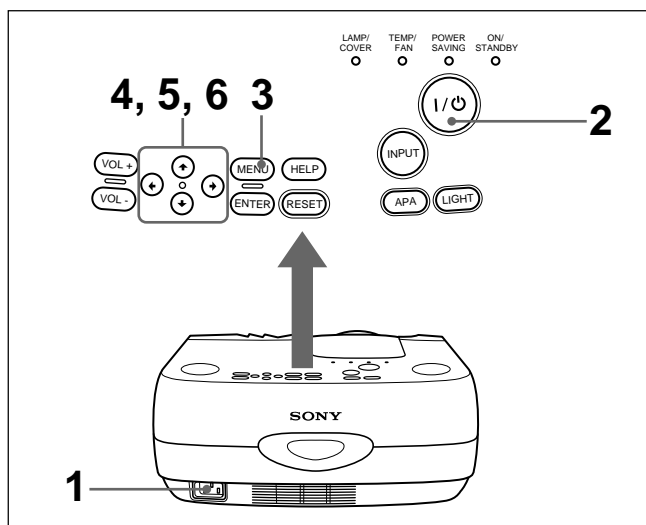

- 1** Plug the AC power cord into the wall outlet.
- 2** Press the I / ⏻ key to turn on the power.
- 3** Press the MENU key.
The menu display appears.
- 4** Select the icon of SET SETTING Menu, the third one, with the ↑ or ↓ key, then press the → or ENTER key.

The SET SETTING Menu appears.

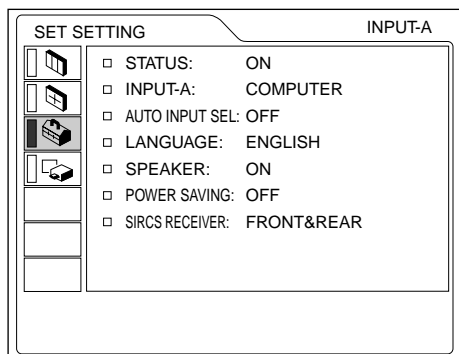

- 5** Select LANGUAGE with the ↑ or ↓ key, then press the → or ENTER key.
- 6** Select the language desired with the ↑ or ↓ key, then press the ← or ENTER key.
The menu changes into the selected language .

To clear the menu display

Press the MENU key.

The menu display disappears automatically if no key is pressed for one minute.

Projecting

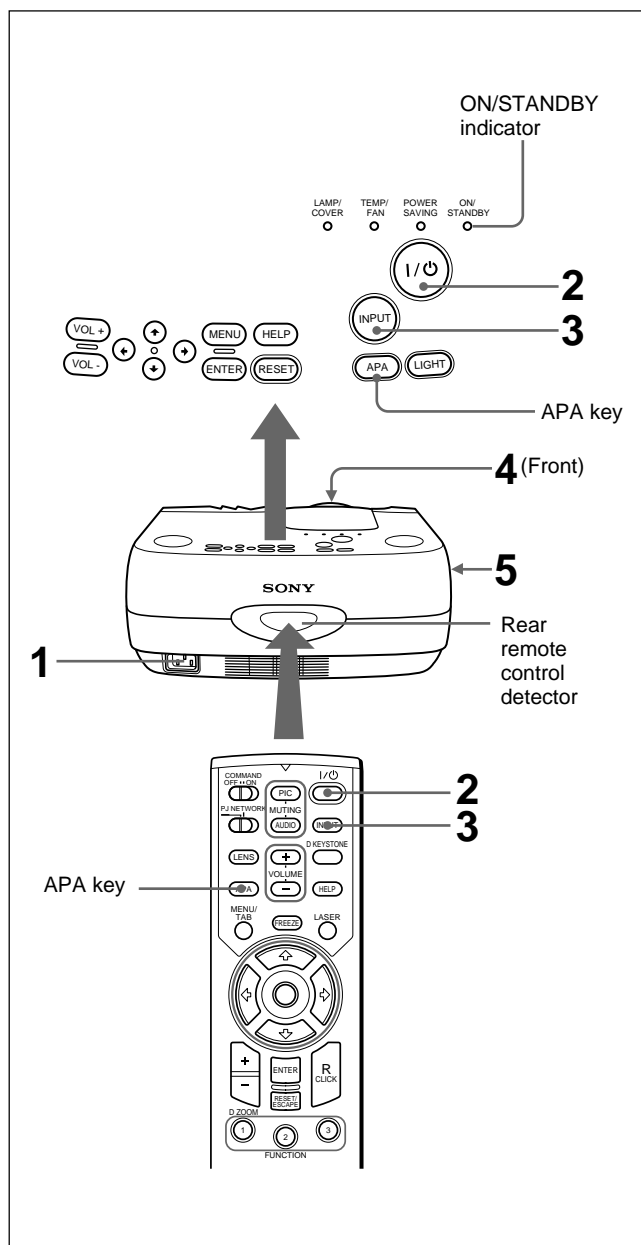

- 1** After all equipment is connected completely, plug the AC power cord into the wall outlet.
The ON/STANDBY indicator lights in red and the projector goes into the standby mode.
- 2** Press the I / ⏻ key.
The ON/STANDBY indicator lights in green.
- 3** Turn on equipment connected to the projector. Press the INPUT key to select the input source.
INPUT-A: Selects audio and video signals input from the INPUT A connector.

- INPUT-B:** Selects audio and video signals input from the INPUT B connector.
- VIDEO:** Selects audio and video signals input from the AUDIO/VIDEO (VIDEO IN) jacks.
- S-VIDEO:** Selects audio and video signals input from the AUDIO/S VIDEO (VIDEO IN) jacks.

Note

The AUDIO (VIDEO IN) jacks are used as audio outputs of both VIDEO and S-VIDEO.

- 4 Turn the zoom ring to adjust the size of the picture.
- 5 Turn the focus ring to adjust the focus.

Note

Looking into the lens when projecting may cause injury to your eyes.

To	Press
Adjust the volume	the VOL +/- keys on the control panel or the VOLUME +/- keys on the Remoter Commander.
Cut off the sound	the AUDIO MUTING key on the Remote Commander. To restore the sound, press the AUDIO MUTING key again or press the VOL + key on the control panel or the VOLUME + key on the Remote Commander.
Cut off the picture	the PIC MUTING key on the Remote Commander. To restore the picture, press the PIC MUTING key again.

To get the clearest picture

You can get the suitable picture when a signal from the computer is input. Press the APA key. The picture is automatically adjusted to be projected clearest.

Notes

- Adjust the signal when the still picture is displayed on the screen.
- Press the APA key when the full image is displayed on the screen. If there are black edges around the image, the APA function will not function properly and the image may extend beyond the screen.
- If you switch the input signal or re-connect a computer, press the APA key again to get the suitable picture.

- “ADJUSTING” appears on the screen. Press the APA key again during the adjustment to restore the original screen.
- “Complete!” appears on the screen when the picture is adjusted properly. The picture may not be adjusted properly depending on the kinds of input signals.
- Adjust the items in the INPUT SETTING menu when you adjust the picture manually.
For details, see page 24 (GB).

To correct the trapezoid

When the projecting image is a trapezoid, change the projector’s position/height by moving the adjuster.
For details on “How to use the adjuster”, see page 10 (GB).

If the image is still a trapezoid, correct it in DIGIT KEYSTONE in the INSTALL SETTING menu.

When the base edge is longer than the upper edge as shown in the figure below:

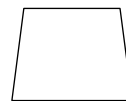

Set the value to negative.

When the upper edge is longer than the base edge as shown in the figure below:



Set the value to positive.

For details on “DIGIT KEYSTONE”, see page 27 (GB).

To turn off the power

- 1 Press the I / ⏻ key.

“Power OFF?” appears on the screen.

Note

The message will disappear if you press any key except the I / ⏻ key, or if you do not press any key for five seconds.

- 2 Press the I / ⏻ key.

The ON/STANDBY indicator flashes in green and the fan continues to run for about 120 seconds to reduce the internal heat. Also, the ON/STANDBY indicator flashes quickly for the first 40 seconds. During this time, you will not be able to turn the power back on with the I / ⏻ key.

- 3 Unplug the AC power cord from the wall outlet after the fan stops running and the ON/STANDBY indicator lights in red.

When you cannot confirm the on-screen message

When you cannot confirm the on-screen message in a certain condition, you can turn off the power by holding the I / ⏻ key for about one second.

Note

Do not unplug the AC power cord while the fan is still running; otherwise, the fan will stop although the internal heat is still high, leading to breakdown of the projector.

About the air filter cleaning

Clean the air filter every 300 hours to ensure optimal performance.

Effective tools for your presentation

To enlarge the image (Digital Zoom function)

You can select a point in the image to enlarge.

- 1 Press the D ZOOM + key on the Remote Commander.

The Digital Zoom icon appears at the center of the image.

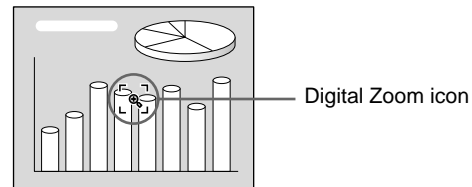

- 2 Move the icon to the point on the image you want to enlarge. Use the arrow keys (↑/↓/←/→) to move the icon.

- 3 Press the D ZOOM + key again.

The image where the icon is located is enlarged. By pressing the + key repeatedly, the image size increases. (ratio of enlargement: max. 4 times)

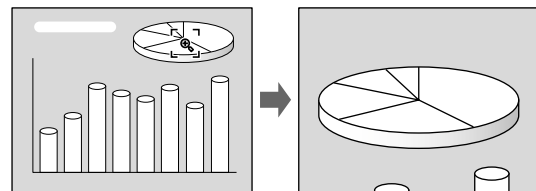

Use the arrow keys (↑/↓/←/→) to scroll the enlarged image.

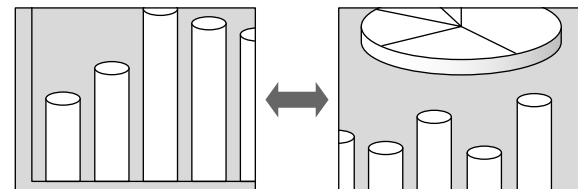

To return the image back to its original size

Press the D ZOOM – key on the Remote Commander.

To use the Laser Pointer function

Press the LASER key on the Remote Commander. The laser pointer appears. The pointer is helpful in indicating a particular point on the screen.

Using the MENU

The projector is equipped with an on-screen menu for making various adjustments and settings.

To select the language used in the menu, see page 26 (GB).

- 1 Press the MENU key.
The menu display appears.
The bar on the icon of the currently selected menu is highlighted in yellow.

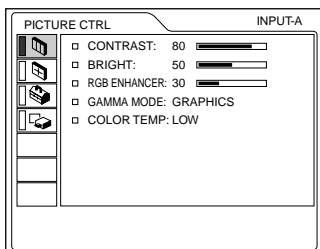

- 2 Use the ↑ or ↓ key to select a menu, then press the → or ENTER key.
The selected menu appears.

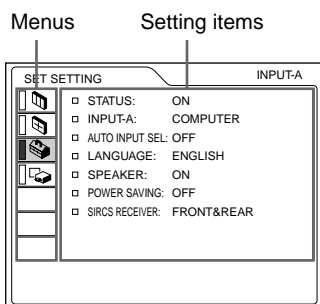

- 3 Make setting or adjustment on an item.
For details on setting individual items, see the relevant menu pages.

To clear the menu display

Press the MENU key.

The menu display disappears automatically if no key is pressed for one minute.

To reset items that have been adjusted

Press the RESET key.

“Complete!” appears on the screen and the settings appearing on the screen will be reset to their factory preset values.

Items which can be reset are:

- “CONTRAST”, “BRIGHT”, “COLOR”, “HUE”, “SHARP” and “RGB ENHANCER” in the PICTURE CTRL menu.
- “DOT PHASE”, “SIZE H” and “SHIFT” in the INPUT SETTING menu.

About the memory of the settings

The settings are automatically stored in the projector memory.

When no signal is input

When there is no input signal, “NO INPUT–Cannot adjust this item.” appears on the screen, and each item cannot be adjusted.

The PICTURE CTRL Menu

The PICTURE CTRL (control) menu is used for adjusting the picture.

Unadjustable items depending on the input signal are not displayed in the menu.

When the video signal is input

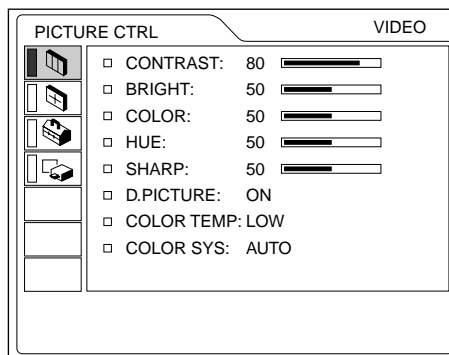

When the RGB signal is input

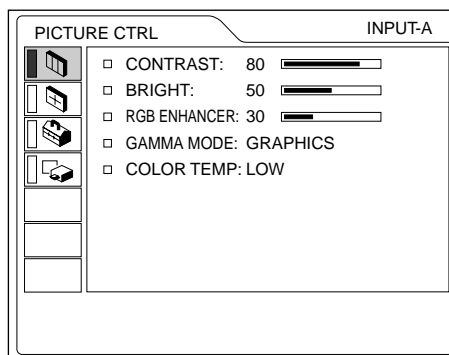

Operation

1. Select an item

Use the ↑ or ↓ key to select the item, then press the → or ENTER key.

2. Adjust an item

- When changing the adjustment level:
To increase the number, press the ↑ or → key.

To decrease the number, press the **↓** or **←** key.
Press the **ENTER** key to restore the original screen.

- When changing the setting:
Press the **↑** or **↓** key to change the setting.
Press the **ENTER** or **←** key to restore the original screen.

CONTRAST

Adjusts the picture contrast.
The higher the setting, the greater the contrast.
The lower the setting, the lower the contrast.

BRIGHT

Adjusts the picture brightness.
The higher the setting, the brighter the picture.
The lower the setting, the darker the picture.

COLOR

Adjusts color intensity.
The higher the setting, the greater the intensity.
The lower the setting, the lower the intensity.

HUE

Adjusts color tones.
The higher the setting, the picture becomes greenish.
The lower the setting, the picture becomes purplish.

SHARP

Adjusts the picture sharpness.
The higher the setting, the sharper the picture.
The lower the setting, the softer the picture.

RGB ENHANCER

Adjusts the picture sharpness when the RGB signals are input.
The higher the setting, the sharper the picture.
The lower the setting, the softer the picture.

D. (Dynamic) PICTURE

Emphasizes the black color.
ON: Emphasizes the black color to produce a bolder “dynamic” picture.
OFF: Reproduces the dark portions of the picture accurately, in accordance with the source signal.

GAMMA MODE

Selects a gamma correction curve.

- GRAPHICS:** Improves the reproduction of half tones. Photos can be reproduced in natural tones.
- TEXT:** Contrasts black and white. Suitable for images that contain lots of text.

COLOR TEMP

Adjusts the color temperature.
HIGH: Makes the white color bluish.
LOW: Makes the white color reddish.

COLOR SYS (System)

Selects the color system of the input signal.
AUTO: Automatically selects one of the following signals: NTSC_{3.58}, PAL, SECAM, NTSC_{4.43}.
PAL-M/N: Automatically selects one of the following signals: PAL-M/PAL-N, NTSC_{3.58}.
Normally, set to AUTO.
If the picture is distorted or colorless, select the color system according to the input signal.

Input signals and adjustable/setting items

Item	Input signal				
	Video or S video (Y/C)	Component	HDTV	RGB ¹⁾	B&W
CONTRAST	●	●	●	●	●
BRIGHT	●	●	●	●	●
COLOR	●	●	●	–	–
HUE	● (NTSC3.58/ 4.43 only)	●	●	–	–
SHARP	●	●	●	–	●
RGB ENHANCER	–	–	–	●	–
D. PICTURE	●	● (15k 60/50 only)	–	–	●
GAMMA MODE	–	–	–	●	–
COLOR TEMP	●	●	●	●	●
COLOR SYS	●	–	–	–	●

● : Adjustable/can be set
– : Not adjustable/can not be set

1) The RGB signals of a computer

The INPUT SETTING Menu

The INPUT SETTING menu is used to adjust the input signal.

Unadjustable items depending on the input signal are not displayed in the menu.

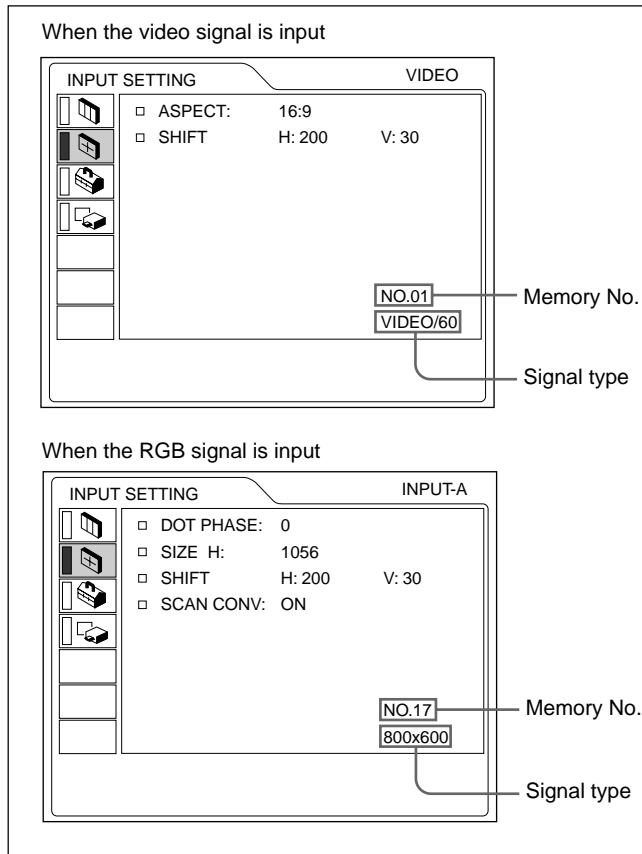

Operation

1. Select an item

Use the \uparrow or \downarrow key to select the item, then press the \rightarrow or ENTER key.

2. Adjust an item

- When changing the adjustment level:
 - To increase the number, press the \uparrow or \rightarrow key.
 - To decrease the number, press the \downarrow or \leftarrow key.
 - Press the ENTER key to restore the original screen.
- When changing the setting:
 - Press the \uparrow or \downarrow key to change the setting.
 - Press the ENTER or \leftarrow key to restore the original screen.

DOT PHASE

Adjusts the dot phase of the LCD panel and the signal input from the INPUT A/B connector. Adjust the picture further for finer picture after the picture is adjusted with pressing the APA key. Adjust the picture to where it looks clearest.

SIZE H

Adjusts the horizontal size of picture input from the INPUT A/B connector.

The higher the setting, the larger the horizontal size of the picture.

The lower the setting, the smaller the horizontal size of the picture. Adjust the setting according to the dots of the input signal. For details on the suitable value for the preset signals, see page 25 (GB).

SHIFT

Adjusts the position of the picture input from the INPUT A/B connectors or VIDEO IN jacks.

H adjusts the horizontal position of the picture.

V adjusts the vertical position of the picture.

As the setting for H increases, the picture moves to the right, and as the setting decreases, the picture moves to the left.

As the setting for V increases, the picture moves up, and as the setting decreases, the picture moves down.

Use the \leftarrow or the \rightarrow key to adjust the horizontal position and the \uparrow and \downarrow key for the vertical position.

ASPECT

Sets the aspect ratio of the picture.

When inputting 16:9 (squeezed) signal from equipment such as a DVD player, set to 16:9.

4:3 : When the picture with ratio 4:3 is input.

16:9 : When the picture with ratio 16:9 (squeezed) is input.

SCAN CONV (Scan converter)

Converts the signal to display the picture according to the screen size.

ON: Displays the picture according to the screen size. The picture will lose some clarity.

OFF: Displays the picture while matching one pixel of input picture element to that of the LCD. The picture will be clear but the picture size will be smaller.

Note

When the XGA or SXGA signal is input, this item will not be displayed.

Input signals and adjustable/setting items

Item	Input signal				
	Video or S video (Y/C)	15k RGB/Component	HDTV	RGB ¹⁾	B&W
DOT PHASE	–	–	●	●	–
SIZE H	–	–	●	●	–
SHIFT	●	●	●	●	●
ASPECT	●	●	–	–	●
SCAN CONV	–	–	–	● (lower than SVGA only)	–

- : Adjustable/can be set
 – : Not adjustable/can not be set

About the preset memory No.

This projector has 43 kinds of preset data for input signals (the preset memory). The memory number of the current input signal and the signal type are displayed when the preset signal is input. This projector automatically detects the signal type. When the signal is registered to the preset memory, a suitable picture is displayed on the screen according to the signal type. You can adjust the picture through the INPUT SETTING menu.

This projector also has 20 kinds of user memories for each INPUT-A/B. When an unpreset signal is input for the first time, memory number is displayed as 0. If the input signal is adjusted in the INPUT SETTING menu, the setting via INPUT-A/B is stored. When more than 20 user memories are registered for each INPUT-A/B, the newest memory is automatically stored over the oldest one.

Preset signals

Memory No.	Preset signal	fH (kHz)	fV (Hz)	Sync	SIZE H	
1	Video 60 Hz	15.734	59.940	H-neg V-neg		
2	Video 50 Hz	15.625	50.000	H-neg V-neg		
3	15k RGB/Component 60 Hz	15.734	59.940	S on G/Y		
4	15k RGB/Component 50 Hz	15.625	50.000	or		
5	HDTV	33.750	60.000	Composite sync		
6	640 × 350	VGA mode 1	31.469	70.086	H-pos V-neg	800
7		VGA VESA ²⁾ 85 Hz	37.861	85.080	H-pos V-neg	832
8	640 × 400	PC-9801 ³⁾ Normal	24.823	56.416	H-neg V-neg	848
9		VGA mode 2	31.469	70.086	H-neg V-pos	800
10		VGA VESA 85 Hz	37.861	85.080	H-neg V-pos	832
11	640 × 480	VGA mode 3	31.469	59.940	H-neg V-neg	800
12		Macintosh 13"	35.000	66.667	H-neg V-neg	864
13		VGA VESA 72 Hz	37.861	72.809	H-neg V-neg	832
14		VGA VESA 75 Hz	37.500	75.000	H-neg V-neg	840
15		VGA VESA 85 Hz	43.269	85.008	H-neg V-neg	832
16	800 × 600	SVGA VESA 56 Hz	35.156	56.250	H-pos V-pos	1024
17		SVGA VESA 60 Hz	37.879	60.317	H-pos V-pos	1056
18		SVGA VESA 72 Hz	48.077	72.188	H-pos V-pos	1040
19		SVGA VESA 75 Hz	46.875	75.000	H-pos V-pos	1056
20		SVGA VESA 85 Hz	53.674	85.061	H-pos V-pos	1048
21	832 × 624	Macintosh 16"	49.724	74.550	H-neg V-neg	1152
22	1024 × 768	XGA VESA 43 Hz	35.524	43.479	H-pos V-pos	1264
23		XGA VESA 60 Hz	48.363	60.004	H-neg V-neg	1344
24		XGA VESA 70 Hz	56.476	69.955	H-neg V-neg	1328
25		XGA VESA 75 Hz	60.023	75.029	H-pos V-pos	1312
26		XGA VESA 85 Hz	68.677	84.997	H-pos V-pos	1376
27		1152 × 864	SXGA VESA 70 Hz	63.995	70.016	H-pos V-pos
28	SXGA VESA 75 Hz		67.500	75.000	H-pos V-pos	1600
29	SXGA VESA 85 Hz		77.487	85.057	H-pos V-pos	1568
30	1152 × 900	Sunmicro LO	61.795	65.960	H-neg V-neg	1504
31		Sunmicro HI	71.713	76.047	Composite sync	1472
32	1280 × 960	SXGA VESA 60 Hz	60.000	60.000	H-pos V-pos	1800
33		SXGA VESA 75 Hz	75.000	75.000	H-pos V-pos	1728
34	1280 × 1024	SXGA VESA 43 Hz	46.433	43.436	H-pos V-pos	1696
35		SXI-5	53.316	50.062	S on G	1680
36		SXGA VESA 60 Hz	63.974	60.013	H-pos V-pos	1696
37		SXGA VESA 75 Hz	79.976	75.025	H-pos V-pos	1688
38		SXGA VESA 85 Hz	91.146	85.024	H-pos V-pos	1728

43	PC Component 480/60P	480/60P (Double frequency NTSC)	31.470	60.000	S on G	
44	575/50P	575/50P (Double frequency PAL)	31.250	50.000	S on G	
45	1080/50I	1080/50I	28.130	50.000		

47	720/60P	720/60P	45.000	60.000		
48	720/50P	720/50P	37.500	50.000		

- 1) The RGB signals of a computer
 2) VESA is a registered trademark of Video Electronics Standard Association.
 3) PC-98 is a registered trademark of NEC Corporation.

Since the data is recalled from the preset memory about the following signals, you can use these preset data by adjusting SIZE H. Make fine adjustment by adjusting SHIFT.

Signal	Memory No.	SIZE H
Super Mac-2	23	1312
SGL-1	23	1320
Macintosh 19"	25	1328
Macintosh 21"	28	1456
Sony News	36	1708
PC-9821 1280 × 1024	36	1600
WS Sunmicro	37	1664

Note

When the aspect ratio of input signal is other than 4:3, a part of the screen is displayed in black.

The SET SETTING Menu

The SET SETTING menu is used for changing the settings of the projector.

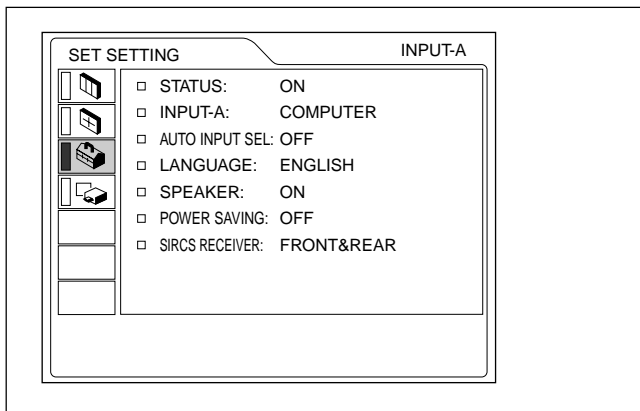

Operation

1. Select an item

Use the **↑** or **↓** key to select the item, then press the **→** or ENTER key.

2. Change the setting

Press the **↑** or **↓** key to change the setting. To restore the original screen, press the ENTER or **←** key.

STATUS (on-screen display)

Sets up the on-screen display.

ON: Shows all of the on-screen displays.

OFF: Turns off the on-screen displays except for the menus, a message when turning off the power, and warning messages.

For details on the warning messages, see page 35 (GB).

INPUT-A

Selects the computer, component, DTV YPBPR or DTV GBR signal input from the 5BNC connector.

Note

If the setting is not correct, "Please check INPUT-A setting." appears on the screen and the color of the picture becomes strange or the picture is not displayed.

AUTO INPUT SEL

When set to ON, the projector detects input signals in the following order: INPUT-A/INPUT-B/VIDEO/S-VIDEO. It indicates the input channel when the power is turned on or the INPUT key is pressed.

LANGUAGE

Selects the language used in the menu and on-screen displays.

Available languages are: English, French, German, Italian, Spanish, Japanese and Chinese.

SPEAKER

Set to OFF to cut off the sound of the internal speakers. When set to OFF, "SPEAKER OFF" appears on the screen when you turn on the power.

POWER SAVING

When set to ON, the projector goes into the power saving mode if no signal is input for 10 minutes.

SIRCS RECEIVER

Selects the remote control detectors (SIRCS receiver) on the front and rear of the projector.

FRONT & REAR: Activates both the front and rear detectors.

FRONT: Activates the front detector only.

REAR: Activates the rear detector only.

The INSTALL SETTING Menu

The INSTALL SETTING menu is used for changing the settings of the projector.

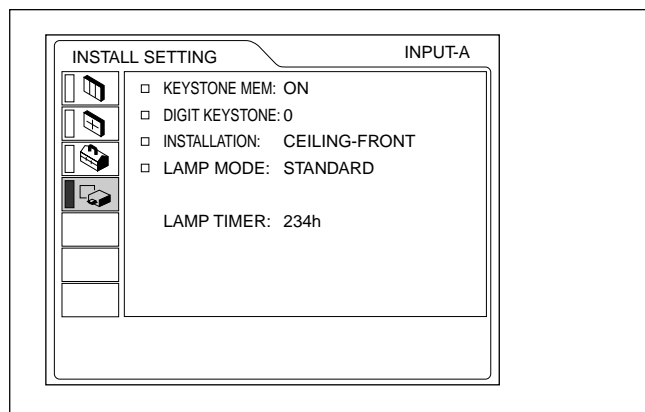

Operation

1. Select an item

Use the **↑** or **↓** key to select the item, then press the **→** or ENTER key.

2. Adjust an item

- When changing the adjustment level:
 - To increase the number, press the **↑** or **→** key.
 - To decrease the number, press the **↓** or **←** key.
 - Press the ENTER key to restore the original screen.
- When changing the setting:
 - Press the **↑** or **↓** key to change the setting.
 - Press the ENTER or **←** key to restore the original screen.

KEYSTONE MEM

ON: DIGIT KEYSTONE setting is stored.

The data is retrieved when the projector power is turned on. The setting will remain the same every time.

OFF: DIGIT KEYSTONE is reset to 0 when the power is turned on next time.

DIGIT KEYSTONE

Corrects the trapezoid caused by the projection angle. If the base edge is longer, set a negative value; if the upper edge is longer, set a positive value to square the image.

INSTALLATION

Sets to reverse the picture horizontally or vertically.

FLOOR-FRONT: The picture is not reversed.

CEILING-FRONT: The picture is reversed horizontally and vertically.

FLOOR-REAR: The picture is reversed horizontally.

CEILING-REAR: The picture is reversed vertically.

Note

In case of using a mirror, be careful of installation since the picture may be reversed.

LAMP MODE

Sets the lamp brightness in the projection.

STANDARD: Illuminates with normal brightness.

LOW: Reduces fan noise and power consumption.

Compared with the STANDARD setting, the brightness of an image projecting under the LOW setting will be low.

If the LAMP MODE is set to LOW, the next time the power is turned on, the lamp will use the STANDARD setting for the first minute, and then go to LOW.

LAMP TIMER

Indicates how long the lamp has been turned on.

Note

This only displays the time. You cannot alter the display.

Installation Examples

Floor Installation

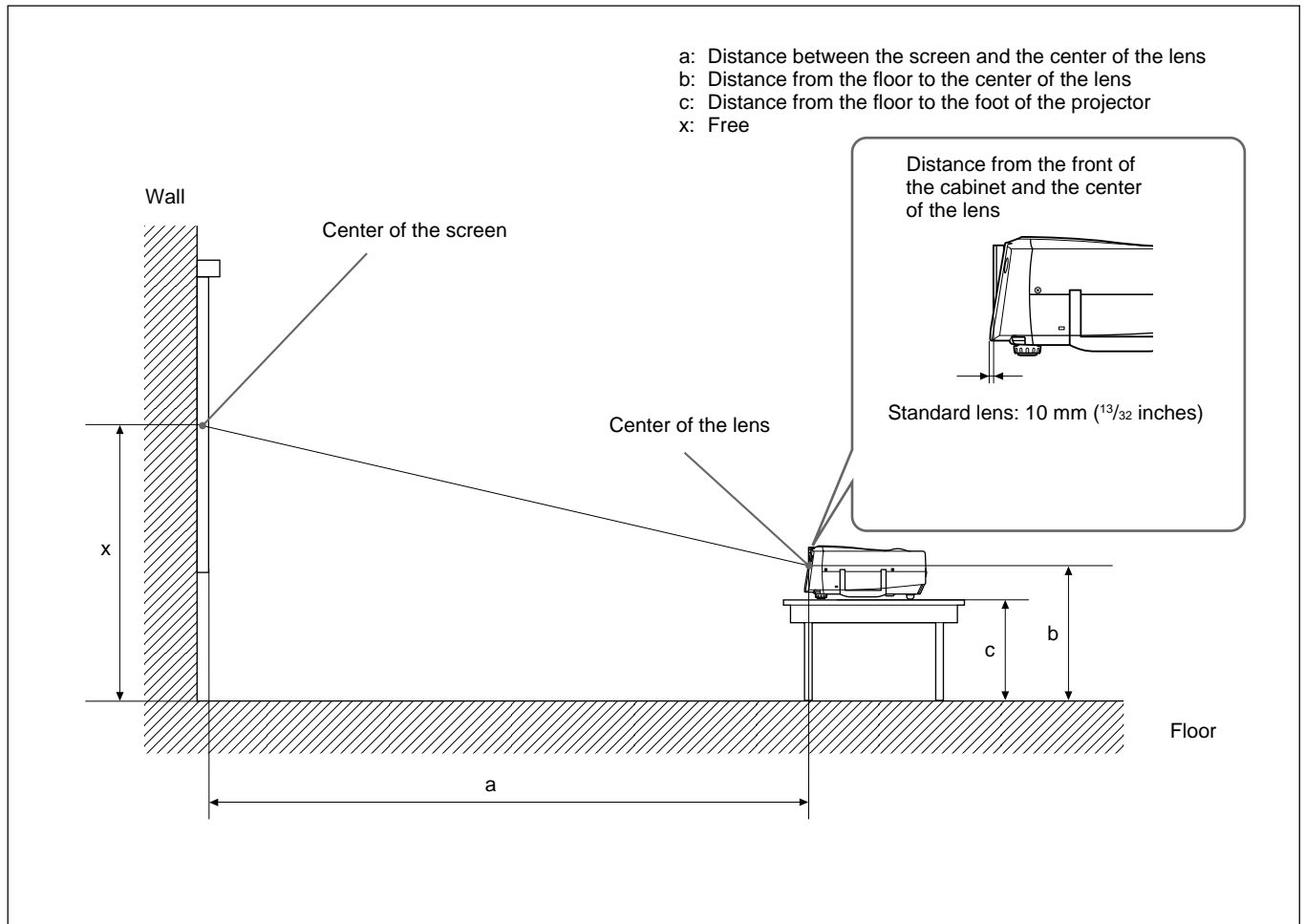

Unit: mm (inches)

Screen size (inches)		40	60	80	100	120	150	180	200	250	300
a	Minimum	1490 (58 ³ / ₄)	2280 (89 ⁷ / ₈)	3060 (120 ¹ / ₂)	3850 (151 ⁵ / ₈)	4630 (182 ³ / ₈)	5810 (228 ⁷ / ₈)	6990 (275 ¹ / ₄)	7770 (306)	9740 (383 ⁵ / ₈)	11700 (460 ³ / ₄)
	Maximum	1820 (71 ³ / ₄)	2780 (109 ¹ / ₂)	3740 (147 ³ / ₈)	4700 (185 ¹ / ₈)	5660 (222 ⁷ / ₈)	7100 (279 ⁵ / ₈)	8540 (336 ³ / ₈)	9500 (374 ¹ / ₈)	11900 (468 ⁵ / ₈)	14300 (563 ¹ / ₈)
b		x-305 (12)	x-457 (18)	x-610 (24)	x-762 (30)	x-914 (36)	x-1143 (45)	x-1372 (54)	x-1524 (60)	x-1905 (75 ¹ / ₈)	x-2286 (90 ¹ / ₈)
c		x-394 (15 ⁵ / ₈)	x-546 (21 ⁵ / ₈)	x-699 (27 ⁵ / ₈)	x-851 (33 ⁵ / ₈)	x-1003 (39 ⁵ / ₈)	x-1232 (48 ⁵ / ₈)	x-1461 (57 ⁵ / ₈)	x-1613 (63 ⁵ / ₈)	x-1994 (78 ⁵ / ₈)	x-2375 (93 ⁵ / ₈)

To calculate the installation measurement (unit: mm)

SS: screen size diagonal (inches)

$$a \text{ (minimum)} = \{(SS \times 50.18/1.3102) - 75.10104\} \times 1.025$$

$$a \text{ (maximum)} = \{(SS \times 64.518746/1.3102) - 107.8977\} \times 0.975$$

$$b = x - (SS/1.3102 \times 9.984)$$

$$c = x - (SS/1.3102 \times 9.984 + 89)$$

Ceiling Installation

When installing the projector on the ceiling, use the PSS-610 Projector Suspension Support.

For ceiling installation, consult with qualified Sony personnel.

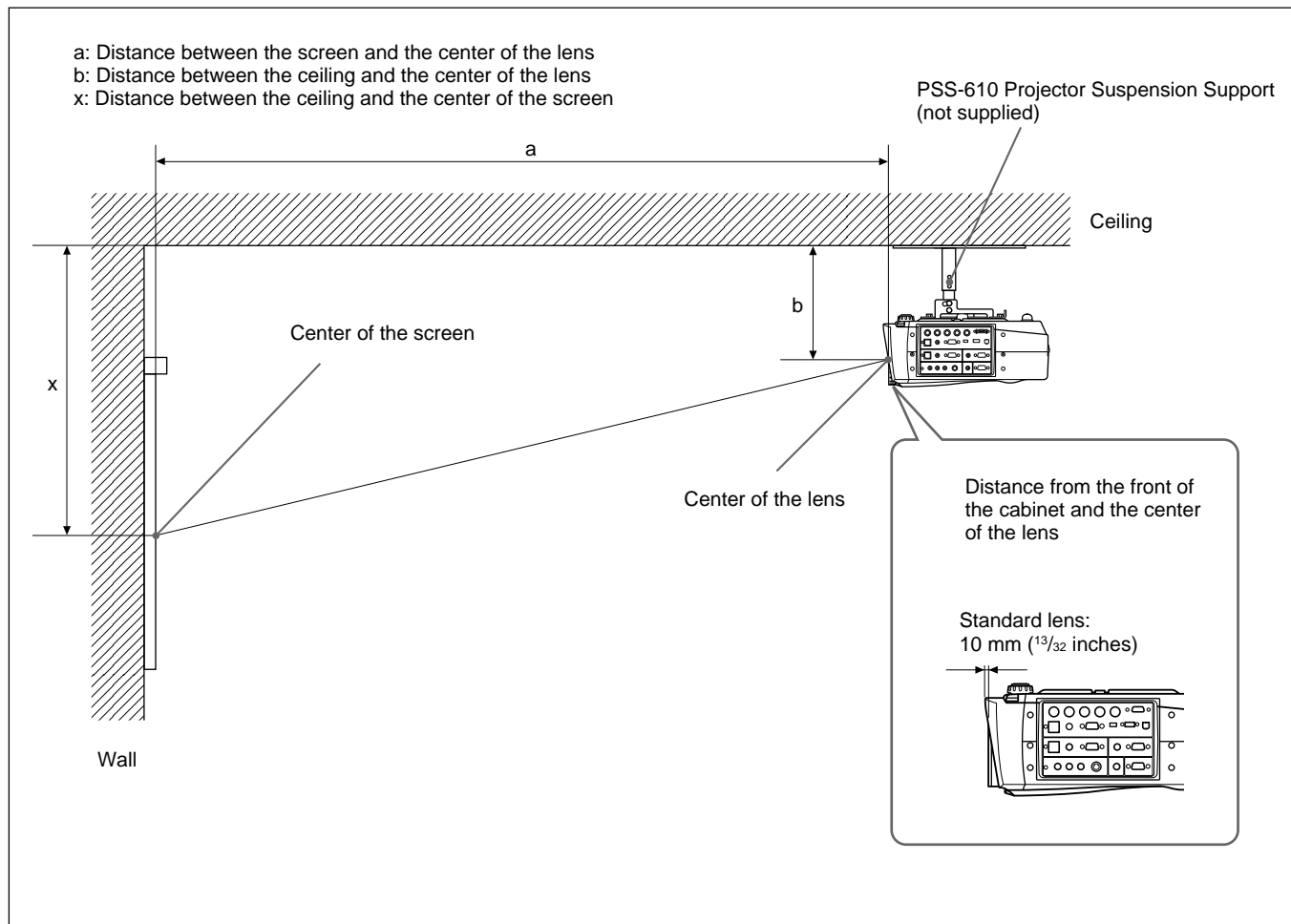

Unit: mm (inches)

Screen size (inches)	80	100	120	150	180	200	250	300	
a	Minimum	3060 (120 1/2)	3850 (151 5/8)	4630 (182 3/8)	5810 (228 7/8)	6990 (275 1/4)	7770 (306)	9740 (383 5/8)	11700 (460 3/4)
	Maximum	3740 (147 3/8)	4700 (185 1/8)	5660 (222 7/8)	7100 (279 5/8)	8540 (336 3/8)	9500 (374 1/8)	11900 (468 5/8)	14300 (563 1/8)
x	b+610 (24)	b+762 (30)	b+914 (36)	b+1143 (45)	b+1372 (54)	b+1524 (60)	b+1905 (75 1/8)	b+2286 (90 1/8)	
b	231/256/281/331/356/381 mm (9 1/8/10 1/8/11 1/8/13 1/8/14 1/8/15 inches) adjustable when using PSS-610								

To calculate the installation measurement (unit: mm)

SS: screen size diagonal (inches)

$$a \text{ (minimum)} = \{(SS \times 50.18/1.3102) - 75.10104\} \times 1.025$$

$$a \text{ (maximum)} = \{(SS \times 64.518746/1.3102) - 107.8977\} \times 0.975$$

$$x = b + (SS/1.3102 \times 9.984)$$

Notes for Installation

Unsuitable Installation

Do not install the projector in the following situations. These installations may cause malfunction or damage to the projector.

Poorly ventilated

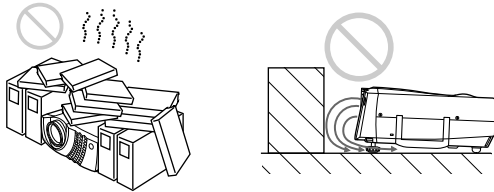

- Allow adequate air circulation to prevent internal heat build-up. Do not place the unit on surfaces (rugs, blankets, etc.) or near materials (curtains, draperies) that may block the ventilation holes. When the internal heat builds up due to the block-up, the temperature sensor will function with the message “High temp.! Lamp off in 1 min.” The power will be turned off automatically after one minute.
- Leave space of more than 30 cm (11 7/8 inches) around the unit.
- Be careful that the ventilation holes may inhale tininess such as a piece of paper.
- If you put something in front of the front ventilation holes, the exhaust may be inhaled into the projector through the ventilation holes at the bottom, causing the internal temperature to rise, which activates the protection circuit. Install the projector so that the exhaust is not blocked.

Highly heated and humid

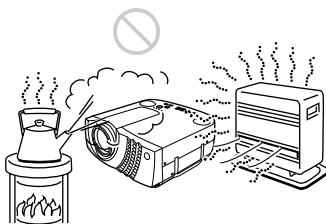

- Avoid installing the unit in a location where the temperature or humidity is very high, or temperature is very low.
- To avoid moisture condensation, do not install the unit in a location where the temperature may rise rapidly.

Very dusty

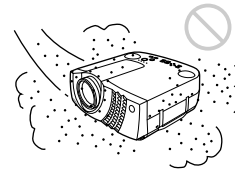

Avoid installing the unit in a location where there is a lot of dust; otherwise, the air filter will be obstructed. The dust blocking the air through the filter may cause raising the internal heat of the projector. Clean it up periodically.

Unsuitable Conditions for Use

Do not do any of the following.

Topping of the unit

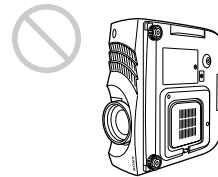

Avoid using as the unit topples over on its side. It may cause malfunction.

Tilting front/rear and right/left

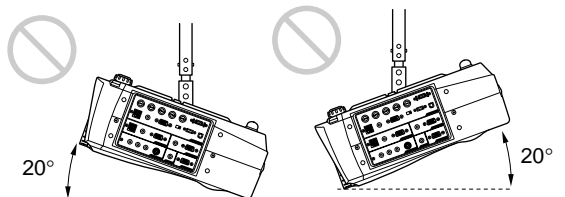
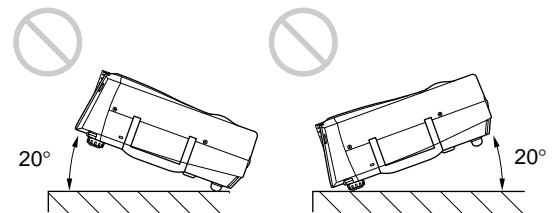
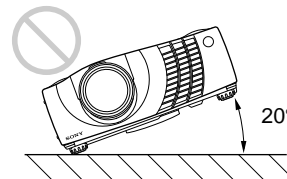

Avoid using as the unit tilts more than 20 degrees. Do not install the unit other than on the floor or ceiling. These installation may cause malfunction.

Blocking the ventilation holes

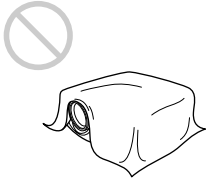

Avoid using something to cover over the ventilation holes; otherwise, the internal heat may build up.



Maintenance

Notes

- If the lamp breaks, consult with qualified Sony personnel.
- Pull out the lamp unit by holding the handle. If you touch the lamp unit, you may be burned or injured.
- When removing the lamp unit, make sure it remains horizontal, then pull straight up. Do not tilt the lamp unit. If you pull out the lamp unit while tilted and if the lamp breaks, the pieces may scatter, causing injury.

Replacing the Lamp

When it is time to replace the lamp, replace the lamp promptly with a new LMP-P201 Projector Lamp. The lamp reaches the end of its life after about 1500 hours for the STANDARD setting, or about 3000 hours for the LOW setting in the LAMP MODE. When it is time to change the lamp, a message which says, "Please replace the LAMP." will be displayed.

When replacing the lamp after using the projector

Turn off the projector, then unplug the power cord. Wait for at least an hour for the lamp to cool.

Note

The lamp becomes a high temperature after turning off the projector with the I / ⏻ key. If you touch the lamp, you may scald your finger. When you replace the lamp, wait for at least an hour for the lamp to cool.

- 1 Place a protective sheet (cloth) beneath the projector.
Hold the projector handle and turn the projector toward the control panel as shown below.

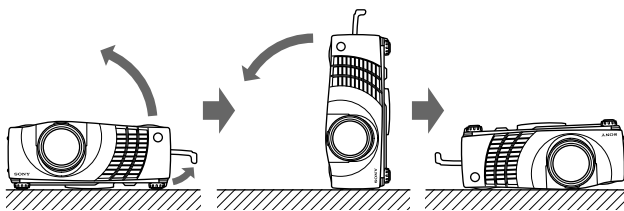

Note

When replacing the lamp, be sure it is on a flat and stable surface.

- 2 Open the lamp cover by loosening one screw with the Philips screwdriver (supplied with the LMP-P201 Projector Lamp).

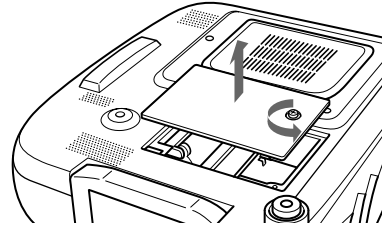

- 3 Loosen two screws on the lamp unit with the Philips screwdriver.

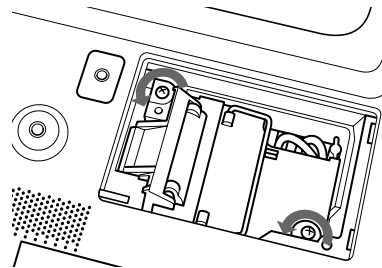

- 4 While holding the handle and keeping the lamp unit horizontal, pull straight up.

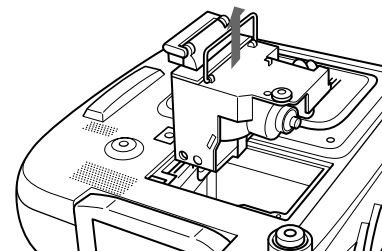

- 5 Insert the new lamp all the way in until it is securely in place. Tighten the screws. Fold down the handle.

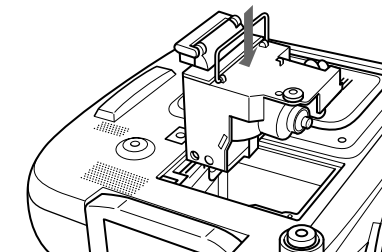

Notes

- Be careful not to touch the glass surface of the lamp.
- The power will not turn on if the lamp is not secured properly.

- 6 Close the lamp cover and tighten the screw.
- 7 Turn the projector back over.
- 8 Connect the power cord and turn the projector to the standby mode.
- 9 Press the following keys on the control panel in the following order for less than in five seconds each: RESET, ←, →, ENTER.

Notes

- Be sure to use the LMP-P201 Projector Lamp for replacement. If you use lamps other than LMP-P201, the projector may cause a malfunction.
- Be sure to turn off the projector and unplug the power cord before replacing the lamp.
- Do not put your hands into the lamp replacement spot, or not fall any liquid or object into it to avoid electrical shock or fire.

Disposal of used projector lamp

As the materials used in this lamp are similar to those of a fluorescent lamp, you should dispose of a used projector lamp in the same way as a fluorescent lamp.

Cleaning the Air Filter

The air filter should be cleaned every 300 hours.

When it becomes difficult to remove the dust from the filter, replace the filter with a new one.

To clean the air filter, follow the steps below:

- 1 Turn off the power and unplug the power cord.
- 2 Remove the air filter cover while holding down the air filter cover button on the filter cover.

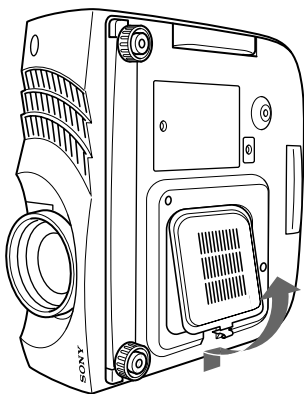

- 3 Peel off the air filter. (The air filter is secured with Velcro tape (3).)

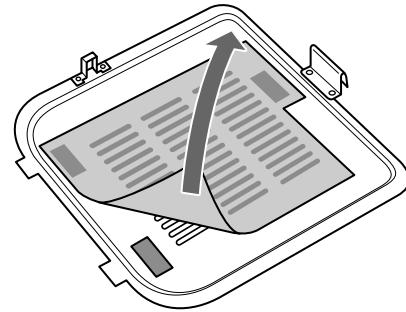

- 4 Remove the dust from the filter with a vacuum cleaner.

- 5 Install the air filter as shown in the figure. Install the air filter cover on the projector.

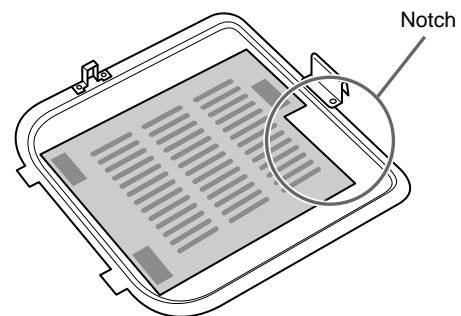

Notes

- Just placing the air filter on the Velcro tapes will not lock the air filter in place. When installing the air filter, place it on the air filter cover and attach by pressing down hard on the three Velcro tapes. Make sure that the air filter is not bent.
- Set the air filter correctly (straight) in the air filter cover. If the air filter is not straight, the filter may malfunction.
- If the air filter is excessively dirty, wash it with a mild detergent solution and dry it in a shaded place. If the dust cannot be removed, replace the air filter with the supplied new one.
- The air filter has front and back sides. Make sure you install the air filter in the right direction. Check the notch on the filter as shown in the figure above and install properly.
- Be sure to attach the air filter cover firmly; the power will not be turned on if it is not closed securely.

Troubleshooting

If you encounter a problem during operation, press the HELP key to display the help messages.

You can get these kinds of help messages:

- Image: A menu is not displayed. Colors are not correct.
- Sound: Sound is not output correctly.
- Other: The indicator lights up/flashes.

If you still have a problem after consulting the help messages, please check the following. If the problem persists, contact your Sony dealer.

Power

Symptom	Cause	Remedy
The power is not turned on.	The power has been turned off and on with the I / ⏻ key at a short interval.	Wait for about 120 seconds before turning on the power (see page 21 (GB)).
	The lamp cover is detached.	Close the lamp cover securely (see page 32 (GB)).
	The air filter cover is detached.	Close the air filter cover securely (see page 33 (GB)).

Image

Symptom	Cause	Remedy
No picture.	Cable is disconnected or not connected properly.	Check that the proper connections have been made (see pages 15 (GB) to 18 (GB)).
	Input selection is incorrect.	Select the input source correctly using the INPUT key (see page 19 (GB)).
	The picture is cut off.	Press the PIC MUTING key to release the muting function (see page 20 (GB)).
	The computer signal is not set to output to external monitor.	Set the computer signal to output to external monitor (see page 15 (GB)).
	The computer signal is set to output to both the LCD of the computer and external monitor.	Set the computer signal to output only to external monitor (see page 15 (GB)).
The picture is noisy.	Noise may appear on the background depending on the combination of the numbers of dot input from the connector and numbers of pixel on the LCD panel.	Change the desktop pattern on the connected computer.
On-screen display does not appear.	STATUS in the SET SETTING menu has been set to OFF.	Set STATUS in the SET SETTING menu to ON (see page 26 (GB)).

Sound

Symptom	Cause	Remedy
No Sound.	Cable is disconnected or not connected properly.	Check that the proper connections have been made (<i>see pages 15 (GB) to 18 (GB)</i>).
	The sound is cut off.	Press the AUDIO MUTING key to release the muting function (<i>see page 20 (GB)</i>).
When inputting sound through AUDIO jack, sound comes through one channel only.	Monaural sound is being input through the AUDIO jack.	Input stereo sound.

Others

Symptom	Cause	Remedy
The LAMP/COVER indicator flashes.	The lamp cover or the air filter cover is detached.	Attach the cover securely (<i>see pages 32 (GB) and 33 (GB)</i>).
The LAMP/COVER indicator lights up.	The lamp has reached the end of its life.	Replace the lamp (<i>see page 32 (GB)</i>).
	The lamp becomes a high temperature.	Wait for 120 seconds to cool down the lamp and turn on the power again (<i>see page 21 (GB)</i>).
The TEMP/FAN indicator flashes.	The fan is broken.	Consult with qualified Sony personnel.
The TEMP/FAN indicator lights up.	The internal temperature is unusually high.	Check to see if nothing is blocking the ventilation holes.
Both LAMP/COVER and TEMP/FAN indicators light up.	The electric system failed.	Consult with qualified Sony personnel.

Warning messages

Use the list below to check the meaning of the messages displayed on the screen.

Message	Meaning	Remedy
High temp.! Lamp off in 1 min.	Internal temperature is too high.	Turn off the power. Check to see if nothing is blocking the ventilation holes.
Frequency is out of range!	This input signal cannot be projected as the frequency is out of the acceptable range of the projector.	Input a signal that is within the range of the frequency.
	The resolution setting of the output signal of a computer is too high.	Set the setting of output to the XGA (<i>see page 15 (GB)</i>).
Please check INPUT-A setting.	You have input RGB signal from the computer when INPUT-A in the SET SETTING menu is set to COMPONENT, DTV YPbPr or DTV GBR.	Set INPUT-A correctly (<i>see page 26 (GB)</i>).
Please replace the LAMP.	It is time to replace the lamp.	Please replace the lamp.

Caution messages

Use the list below to check the meaning of the messages displayed on the screen.

Message	Meaning	Remedy
NO INPUT	No input signal	Check connections (<i>see page 15 (GB) to 18 (GB)</i>).
Not applicable!	You have pressed the wrong key.	Press the appropriate key.
SPEAKER OFF	SPEAKER in the SET SETTING menu has been set to OFF.	Set SPEAKER to ON if necessary (<i>see page 26 (GB)</i>).

Specifications

Optical characteristics

Projection system	3 LCD panels, 1 lens, projection system
LCD panel	1.3-inch TFT SONY LCD panel with micro-lens array, 2,359,296 pixels (1024 × 768 pixels × 3)
Lens	Approx. 1.3 times zoom lens f 50.8 to 64.0 mm/F 1.7 to 2.0
Lamp	200 W UHP
Projection picture size	Range: 40 to 300 inches (diagonal measure)
Light output	ANSI lumen ¹⁾ 3000 lm
Throwing distance	40-inch: 1490 to 1820 mm (58 3/4 to 71 3/4 inches) 60-inch: 2280 to 2780 mm (89 7/8 to 109 1/2 inches) 80-inch: 3060 to 3740 mm (120 1/2 to 147 3/8 inches) 100-inch: 3850 to 4700 mm (151 5/8 to 185 1/8 inches) 120-inch: 4630 to 5660 mm (182 3/8 to 222 7/8 inches) 150-inch: 5810 to 7100 mm (228 7/8 to 279 5/8 inches) 180-inch: 6990 to 8540 mm (275 1/4 to 336 3/8 inches) 200-inch: 7770 to 9500 mm (306 to 374 1/8 inches) 250-inch: 9740 to 11900 mm (383 5/8 to 468 5/8 inches) 300-inch: 11700 to 14300 mm (460 3/4 to 563 1/8 inches)

Electrical characteristics

Color system	NTSC _{3.58} /PAL/SECAM/NTSC _{4.43} /PAL-M/PAL-N system, switched automatically/manually
Resolution	750 horizontal TV lines (Video input) 1024 × 768 pixels (RGB input)
Acceptable computer signals	fH: 19 to 95 kHz fV: 50 to 92 Hz (up to SXGA)
Acceptable video signals	15 kHz RGB/Component 50/60Hz, Progressive component 50/60Hz, DTV (480/60P, 575/50P, 720/60P, 720/50P, 1080/60I, 1080/50I), Composite video, Y/C video

Speaker	Wide frequency range 3 speakers system, Woofers: 65 mm (2 5/8 inches) diameter, max. 3 W Tweeter: 45 mm (1 3/16 inches) diameter, max. 1 W × 2 (stereo)
---------	---

Input/Output

Video/audio input	VIDEO: phono type Composite video: 1 Vp-p ±2 dB sync negative (75 ohms terminated) S VIDEO: Y/C mini DIN 4-pin type (male) Y (luminance): 1 Vp-p ±2 dB sync negative (75 ohms terminated) C (chrominance): burst 0.286 Vp-p ±2 dB (NTSC) (75 ohms terminated), burst 0.3 Vp-p ±2 dB (PAL) (75 ohms terminated) AUDIO: Phono type × 2 500 mVrms, impedance more than 47 kilohms
INPUT A	HD D-sub15-pin (female)/ 5BNC (female)/ Digital Interface Switched Analog RGB: HD D-sub15-pin (female) R: 0.7 Vp-p ±2 dB (75 ohms terminated) G: 0.7 Vp-p ±2 dB (75 ohms terminated) G with sync: 1 Vp-p ±2 dB sync negative (75 ohms terminated) B: 0.7 Vp-p ±2 dB (75 ohms terminated) SYNC/HD: Composite sync input: 1-5 Vp-p high impedance, positive/negative Horizontal sync input: 1-5 Vp-p high impedance, positive/negative VD: Vertical sync input: 1-5 Vp-p high impedance, positive/negative Analog RGB/component: 5BNC (female) R/R-Y: 0.7 Vp-p ±2 dB (75 ohms terminated)

1) ANSI lumen is a measuring method of American National Standard IT 7.228.

G: 0.7 Vp-p ±2 dB (75 ohms terminated)
 G with sync/Y: 1 Vp-p ±2 dB sync negative (75 ohms terminated)
 B/B-Y: 0.7 Vp-p ±2 dB (75 ohms terminated)
 SYNC/HD:
 Composite sync input: 1-5 Vp-p high impedance, positive/negative
 Horizontal sync input: 1-5 Vp-p high impedance, positive/negative
 VD:
 Vertical sync input: 1-5 Vp-p high impedance, positive/negative
DIGITAL RGB: DFP 20-pin (TMDS)
USB HUB: Up (B type: female) × 1, Down (A type: female) × 1
MOUSE (output): 13-pin (female)
(For details, see “Pin assignment” on page 38 (GB).)
AUDIO: Stereo minijack
 500 mVrms, impedance more than 47 kilohms
INPUT B
Analog RGB: HD D-sub15-pin (female)
 R: 0.7 Vp-p ±2 dB (75 ohms terminated)
 G: 0.7 Vp-p ±2 dB (75 ohms terminated)
 G with sync: 1 Vp-p ±2 dB sync negative (75 ohms terminated)
 B: 0.7 Vp-p ±2 dB (75 ohms terminated)
 SYNC/HD:
 Composite sync input: 1-5 Vp-p high impedance, positive/negative
 Horizontal sync input: 1-5 Vp-p high impedance, positive/negative
 VD:
 Vertical sync input: 1-5 Vp-p high impedance, positive/negative
MOUSE (output): 13-pin (female)
(For details, see “Pin assignment” on page 38 (GB).)
AUDIO: Stereo minijack
 500 mVrms, impedance more than 47 kilohms
OUTPUT
MONITOR OUT: HD D-sub 15-pin (female)

R/R-Y,G/Y,B/B-Y: Gain Unity,75ohms
 SYNC/HD,VD: 4Vp-p (open), 1Vp-p (75ohms)
 * DIGITAL RGB signal is not output from MONITOR OUT terminal.
AUDIO OUT (variable out):
 Stereo minijack
 max. 1 Vrms, When an input signal is 500 mVrms, impedance less than 5 kilohms
REMOTE CONTROL S IN/PLUG IN POWER
 RS-232C: D-sub 9-pin (female)
 Stereo minijack 5Vp-p, plug in power, DC5V
Safety regulations: UL1950, cUL1950, DHHS (Laser), DNHW (Laser), FCC Class A, IC Class A, EN60 950 (NEMKO), CE, C-Tick, EN60 825-1 (Laser), VCCI class B, JEITA

Laser beam

Laser type Class 2
 Wavelength 645 nm
 Output 1 mW

General

Dimensions 339 × 142 × 335 mm (13 3/8 × 5 5/8 × 13 1/4 inches) (w/h/d)
Mass Approx. 7.2 kg (15 lb 14 oz)
Power requirements AC 100 to 240 V, 50/60 Hz
Power consumption Max. 290 W (Standby mode: 5 W)
Heat dissipation 989.6 BTU
Operating temperature 0°C to 40°C (32°F to 104°F)
Operating humidity 35% to 85% (no condensation)
Storage temperature -20°C to 60°C (-4°F to 140°F)
Storage humidity 10% to 90%
Supplied accessories
 Remote Commander (1)
 Size AA (R6) batteries (2)
 HD D-sub 15-pin Cable (1) (1-791-992-11)

(Continued)

- Mouse Cable
 - SIC-S22 (for PS/2) (2 m) (1)
(1-783-501-11)
- USB Cable A type – B type (2 m)
(1) (1-790-081-11)
- Lens Cap (1)
- AC power cord (1)
- Air filter (for replacement) (1)
- Operating Instructions (1)
- Installation Manual for Dealers (1)
- Warranty Booklet (1)

Design and specifications are subject to change without notice.

Optional accessories

- Projector Lamp LMP-P201 (for replacement)
- Projector Suspension Support PSS-610
- Carrying Case VLC-600¹⁾
- Monitor Cable
 - SMF-400 (HD D-sub 15-pin (male) ↔ 5 × BNC (male))
 - SMF-410 (HD D-sub 15-pin (male) ↔ HD D-sub 15-pin (male))
- Signal cable
 - SMF-402 (HD D-sub 15-pin (male) ↔ 3 × phono type (male))
- Signal Interface Cable
 - SIC-10 (5 × BNC (male) ↔ 5 × BNC (male))
- Digital Signal Cable
 - SMF-D102 (DFP 20-pin ↔ DFP 20-pin)
 - SMF-D110 (DFP 20-pin ↔ DFP 20-pin)
- Mouse Cable
 - SIC-S21 (for Serial) (2 m)
 - SIC-S22 (for PS/2) (2 m)
- Projection Lens
 - Long Focus Zoom Lens VPLL-ZM101
 - Short Focus Zoom Lens VPLL-ZM31
 - Fixed Short Focus Lens VPLL-FM21

Some of the items may not be available in some areas. For details, please consult your nearest Sony office.

Pin assignment

RGB input connector (HD D-sub 15-pin, female)

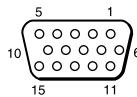

1	R	9	N.C.
2	G	10	GND
3	B	11	GND
4	N.C.	12	DDC/SDA
5	GND	13	HD/C.Sync
6	GND (R)	14	VD
7	GND (G)	15	DDC/SCL
8	GND (B)		

MOUSE connector (13-pin, female)



1	RTS	8	R
2	GND	9	98/AT/TXD
3	XA	10	+5V/DTR
4	XB	11	CLOCK
5	YA	12	DATA
6	YB	13	RXD
7	L/PS		

RS-232C connector (D-sub 9-pin, female)

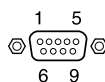

1	DCD	6	DSR
2	RX DA	7	RTS
3	TX DA	8	CTS
4	DTR	9	RI
5	GND		

1) VLC-600 may not be available in some areas. For details, please consult your nearest Sony office.

DIGITAL RGB input connector (DFP 20-pin, female)

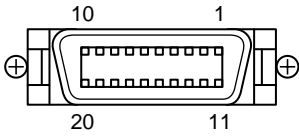

1	TX0-	11	TXC-
2	TX0+	12	TXC+
3	TX0 SHIELD	13	TXC SHIELD
4	TX2 SHIELD	14	TX1 SHIELD
5	TX2-	15	TX1-
6	TX2+	16	TX1+
7	DDC/SCL	17	NC
8	DDC/SDA	18	SENSE
9	NC	19	+5V DC
10	NC	20	GND

USB connector

Plug B
(female)

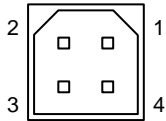

Plug A

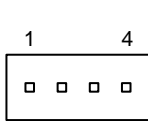

1	+5V
2	D-
3	D+
4	GND

Mouse cable pin assignment

SIC-S22

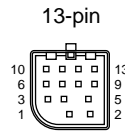

mini DIN 6-pin

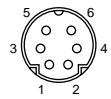

1	RTS	8	R
2	GND	9	98/AT/TXD
3	XA	10	+5V/DTR
4	XB	11	CLOCK
5	YA	12	DATA
6	YB	13	RXD
7	L/PS		

1	DATA
2	NC
3	GND
4	+5V
5	CLOCK
6	NC

Dimensions

Front

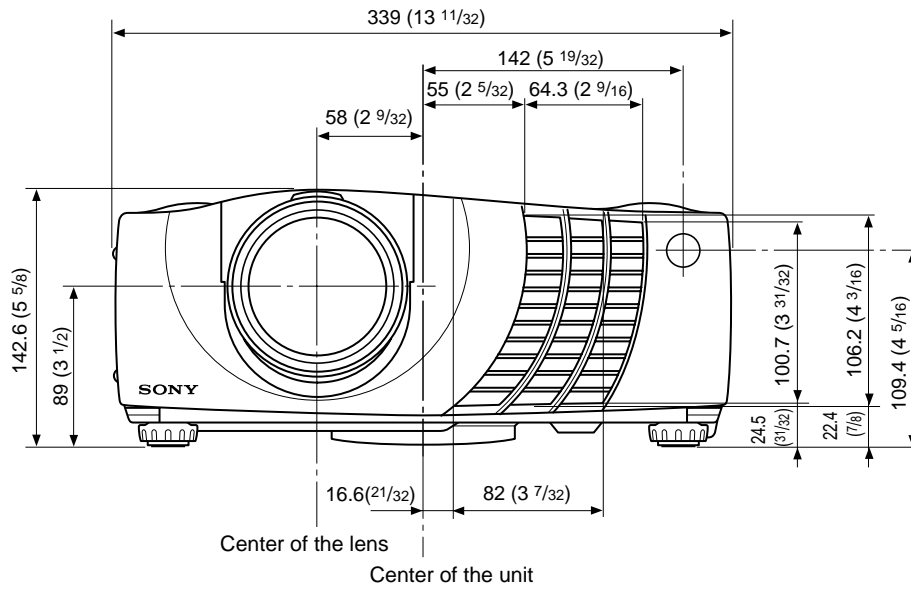

Top

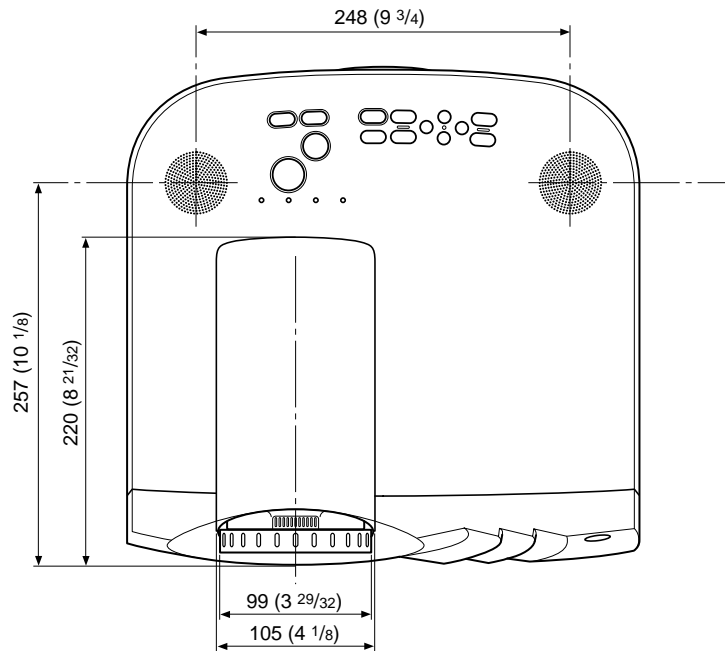

Unit: mm (inches)

Side

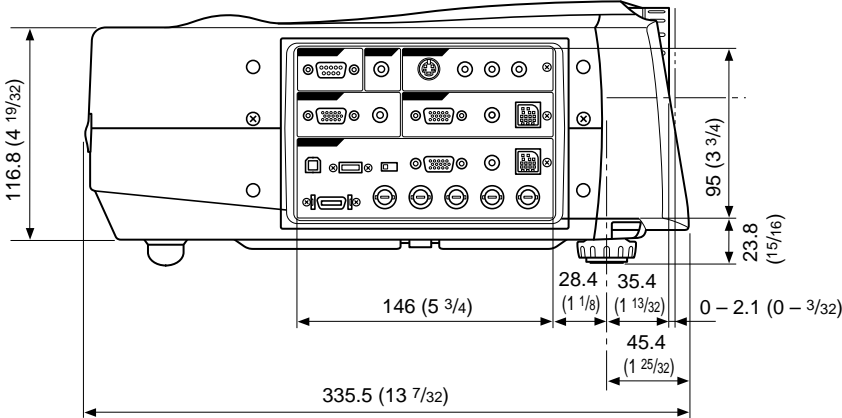

Bottom

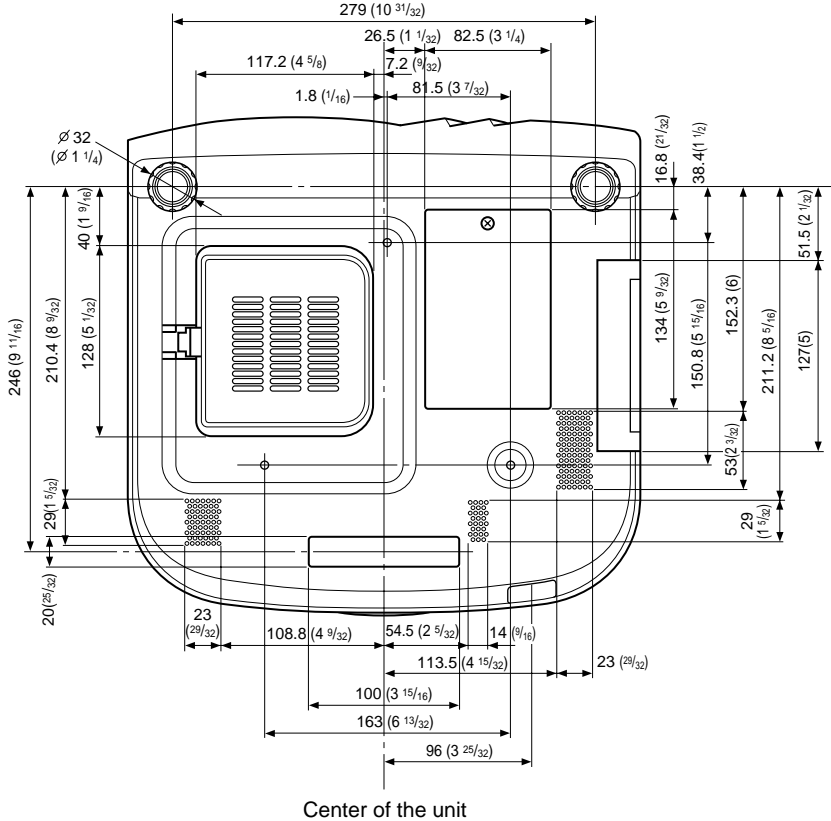

Center of the unit

Unit: mm (inches)

Index

A

- Adjuster 10 (GB)
- Adjusting
 - memory of the settings 22 (GB)
 - the picture 22 (GB)
 - the picture size/shift 24 (GB)
- Air filter 33 (GB)
- APA function 11 (GB), 20 (GB)
- ASPECT 24 (GB)
- AUTO INPUT SEL 26 (GB)

B

- Battery
 - installation 14 (GB)
 - notes 14 (GB)
- BRIGHT 23 (GB)

C

- Carrying handle 9 (GB)
- COLOR 23 (GB)
- COLOR SYS (System) 23 (GB)
- COLOR TEMP 23 (GB)
- Condensation 30 (GB)
- Connections
 - component equipment 18 (GB)
 - computer 15 (GB)
 - VCR 18 (GB)
- CONTRAST 23 (GB)
- Cut off
 - the picture 20 (GB)
 - the sound 20 (GB)

D, E, F

- DIGIT KEYSTONE 27 (GB)
- DIGITAL RGB input connector 12 (GB)
 - pin assignment 39 (GB)
- DIGITAL RGB/5BNC/RGB switch 12 (GB)
- Dimensions 40 (GB)
- D. (Dynamic) PICTURE 23 (GB)
- DOT PHASE 24 (GB)
- 5BNC input connectors 12 (GB)

G

- GAMMA MODE 23 (GB)

H

- HUE 23 (GB)

I, J, K

- INPUT-A 26 (GB)
- INPUT SETTING menu 24 (GB)
- INSTALL SETTING menu 27 (GB)
- INSTALLATION 27 (GB)
- Installation examples 28 (GB)
 - on a ceiling 29 (GB)
 - on a floor 28 (GB)
- KEYSTONE MEM 27 (GB)

L

- LAMP MODE 27 (GB)
- Lamp replacement 32 (GB)
- LAMP TIMER 27 (GB)
- LANGUAGE 26 (GB)
- Location and function of controls
 - connector panel 12 (GB)
 - control panel 11 (GB)
 - front/left side 9 (GB)
 - rear/right side/bottom 9 (GB)
 - Remote Commander 13 (GB)

M, N

- Menu
 - clearing the menu display 22 (GB)
 - INPUT SETTING menu 24 (GB)
 - INSTALL SETTING menu 27 (GB)
 - PICTURE CTRL menu 22 (GB)
 - SET SETTING menu 26 (GB)
 - using the menu 22 (GB)
- Messages
 - cautions 35 (GB)
 - warnings 35 (GB)
- Mouse cable
 - connection 16 (GB)
 - pin assignment 39 (GB)
- Mouse connector 12 (GB)
 - pin assignment 38 (GB)
- Notes for installation 30 (GB)
 - unsuitable conditions for use 30 (GB)
 - unsuitable installation 30 (GB)

O

- Optional accessories 38 (GB)

P, Q

- PICTURE CTRL menu 22 (GB)
- Pin assignment 38 (GB)
- Power
 - turn off 21 (GB)
 - turn on 19 (GB)
- POWER SAVING 11 (GB), 27 (GB)
- Precautions 7 (GB)
- Projecting 19 (GB)
- PSS-610 Projector Suspension Support 29 (GB)

R

- Remote Commander
 - battery installation 14 (GB)
 - D ZOOM key 13 (GB), 21 (GB)
 - FUNCTION key 13 (GB)
 - HELP key 14 (GB)
 - laser pointer function 13 (GB), 21 (GB)
 - location and function of controls 13 (GB)
- Remote control detector
 - front 9 (GB)
 - rear 9 (GB)
 - setting 27 (GB)
- Reset
 - resettable items 22 (GB)
 - resetting the item 22 (GB)
- RGB ENHANCER 23 (GB)
- RGB input connector 12 (GB)
 - pin assignment 38 (GB)
- RS-232C connector 12 (GB)
 - pin assignment 38 (GB)

S

- SCAN CONV (Scan converter) 24 (GB)
- Screen size 14 (GB), 25 (GB), 36 (GB)
- SET SETTING menu 26 (GB)
- SHARP 23 (GB)
- SHIFT 24 (GB)
- SIRCS RECEIVER 9 (GB), 27 (GB)
- SIZE H 24 (GB)
- SPEAKER 26 (GB)
- Specifications 36 (GB)
- STATUS (on-screen display) 26 (GB)
- Supplied accessories 37 (GB)

T, U

- Troubleshooting 34 (GB)
- USB connector 12 (GB)
 - pin assignment 39 (GB)

V, W, X, Y, Z

- Ventilation holes
 - exhaust 9 (GB)
 - intake 9 (GB)