

LCD Data Projector

Operating Instructions

GB

VPL-PX1

WARNING

To prevent fire or shock hazard, do not expose the unit to rain or moisture.

To avoid electrical shock, do not open the cabinet. Refer servicing to qualified personnel only.

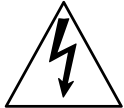

This symbol is intended to alert the user to the presence of uninsulated “dangerous voltage” within the product’s enclosure that may be of sufficient magnitude to constitute a risk of electric shock to persons.



This symbol is intended to alert the user to the presence of important operating and maintenance (servicing) instructions in the literature accompanying the appliance.

For the customers in the USA

This equipment has been tested and found to comply with the limits for a Class A digital device, pursuant to Part 15 of the FCC Rules. These limits are designed to provide reasonable protection against harmful interference when the equipment is operated in a commercial environment. This equipment generates, uses, and can radiate radio frequency energy and, if not installed and used in accordance with the instruction manual, may cause harmful interference to radio communications. Operation of this equipment in a residential area is likely to cause harmful interference in which case the user will be required to correct the interference at his own expense.

You are cautioned that any changes or modifications not expressly approved in this manual could void your authority to operate this equipment.

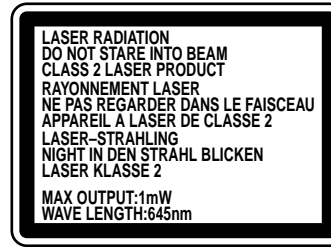

This label is located on the rear of the Remote Commander.



This label is located on the side of the Remote Commander.

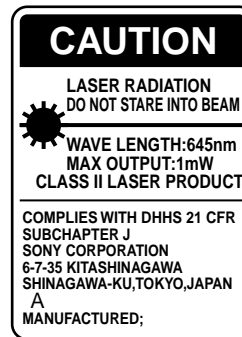

This label is located on the rear of the Remote Commander.



This label is located on the rear of the Remote Commander.

Laser light shines out of this window.



Caution

use of controls or adjustments or performance of procedures other than those specified herein may result in hazardous radiation exposure.

Notes

- Do not aim the laser at people or not look into the laser transmitter.
- When the Remote Commander causes malfunction, consult with qualified Sony personnel. We change the Remote Commander as new one according to the guarantee.

For the customers in Canada

This Class A digital apparatus complies with Canadian ICES-003.

For the customers in the United Kingdom

WARNING

THIS APPARATUS MUST BE EARTHED

IMPORTANT

The wires in this mains lead are coloured in accordance with the following code:

Green-and-Yellow: Earth
Blue: Neutral
Brown: Live

As the colours of the wires in the mains lead of this apparatus may not correspond with the coloured markings identifying the terminals in your plug proceed as follows:

The wire which is coloured green-and-yellow must be connected to the terminal in the plug which is marked by the letter E or by the safety earth symbol \perp or coloured green or green-and-yellow.

The wire which is coloured blue must be connected to the terminal which is marked with the letter N or coloured black.

The wire which is coloured brown must be connected to the terminal which is marked with the letter L or coloured red.

Voor de klanten in Nederland



Bij dit product zijn batterijen geleverd.
Wanneer deze leeg zijn, moet u ze niet weggooien maar inleveren als KCA.

The socket-outlet should be installed near the equipment and be easily accessible.

Warning on power connection

Use a proper power cord for your local power supply.

	The United States, Canada		Continental Europe		UK, Ireland, Australia, Newzealand	Japan
Plug type	VM0233	290B	YP-12A	COX-07	— ¹⁾	VM1296
Female end	VM0089	386A	YC-13B	COX-02	VM0310B	VM10505
Cord type	SJT	SJT	H05VV-F	H05VV-F	N13237/CO-228	HVCTF
Rated Voltage & Current	10A/125V	10A/125V	10A/250V	10A/250V	10A/250V	13A/125V
Safety approval	UL/CSA	UL/CSA	VDE	VDE	VDE	DENTORI

1) Note: Use an appropriate rating plug which is applied to local regulations.

Table of Contents

Overview

Precautions	6 (GB)
Features	7 (GB)
Location and Function of Controls	8 (GB)
Front/Left Side	8 (GB)
Rear/Right Side/Bottom	8 (GB)
Control panel	10 (GB)
Connector panel	11 (GB)
Remote Commander	12 (GB)

Setting up and projecting

Installing the Projector	14 (GB)
Connecting	14 (GB)
Connecting with a Computer	14 (GB)
Connecting with a VCR/15k RGB/ Component Equipment	16 (GB)
Projecting	17 (GB)

Adjustments and settings using the menu

Using the MENU	19 (GB)
The PICTURE CTRL Menu	19 (GB)
The INPUT SETTING Menu	21 (GB)
The SET SETTING Menu	23 (GB)

Maintenance

Maintenance	24 (GB)
Replacing the Lamp	24 (GB)
Cleaning the Air Filter	25 (GB)
Troubleshooting	26 (GB)

Other

Tips for Installation	28 (GB)
Unsuitable Installation	28 (GB)
Notes on Installation	28 (GB)
Specifications	29 (GB)
Index	32 (GB)

Precautions

On safety

- Check that the operating voltage of your unit is identical with the voltage of your local power supply.
- Should any liquid or solid object fall into the cabinet, unplug the unit and have it checked by qualified personnel before operating it further.
- Unplug the unit from the wall outlet if it is not to be used for several days.
- To disconnect the cord, pull it out by the plug. Never pull the cord itself.
- The wall outlet should be near the unit and easily accessible.
- The unit is not disconnected to the AC power source (mains) as long as it is connected to the wall outlet, even if the unit itself has been turned off.
- Do not look into the lens while the lamp is on.
- Do not aim the laser at people or not look into the laser transmitter.
- Do not place your hand or objects near the ventilation holes — the air coming out is hot.
- Be careful not to catch your fingers by the adjuster when you lift up the projector. Do not push hard on the top of the projector with the adjuster out.

On illumination

- To obtain the best picture, the front of the screen should not be exposed to direct lighting or sunlight.
- Ceiling-mounted spot lighting is recommended. Use a cover over fluorescent lamps to avoid lowering the contrast ratio.
- Cover any windows that face the screen with opaque draperies.
- It is desirable to install the projector in a room where floor and walls are not of light-reflecting material. If the floor and walls are of reflecting material, it is recommended that the carpet and wall paper be changed to a dark color.

On preventing internal heat build-up

After you turn off the power with the I / ⏻ key on the Remote Commander or on the control panel, do not disconnect the unit from the wall outlet while the cooling fan is still running.

Caution

The projector is equipped with ventilation holes (intake) on the right side and ventilation holes (exhaust) on front and rear. Do not block or place anything near these holes, or internal heat build-up may occur, causing picture degradation or damage to the projector.

On cleaning

- To keep the cabinet looking new, periodically clean it with a soft cloth. Stubborn stains may be removed with a cloth lightly dampened with a mild detergent solution. Never use strong solvents, such as thinner, benzene, or abrasive cleansers, since these will damage the cabinet.
- Avoid touching the lens. To remove dust on the lens, use a soft dry cloth. Do not use a damp cloth, detergent solution, or thinner.
- Clean the filter at regular intervals.

On repacking

- Save the original shipping carton and packing material; they will come in handy if you ever have to ship your unit. For maximum protection, repack your unit as it was originally packed at the factory.

Features

High portability

- **Light weight/small size**

This projector has come to miniaturized to approx. 4 kg (8 lb 13 oz) of mass by adopting magnesium die-casting body. And a carrying handle is equipped with the projector. You can easily carry it with your computer.

Reduced noise

Because the projector is using a new cooling mechanism, noise has been reduced.

Stability

This projector utilizes a new placing angle adjuster to improve stability.

High brightness, high picture quality

- **High brightness**

Adopting the new developed optical system and the new developed 120 W UHP lamp allow high brightness (light output 1000 ANSI lumen) and excellent uniformity on the picture.

- **High resolution**

Three 0.9-inch, about 790,000 pixel XGA panels with micro-lens arrays provide a resolution of 1024 × 768 dots for RGB input and 750 horizontal TV lines for video input.

Simple setup, easy presentation

- **Simple setup with external equipment**

This projector is preset for 37 kinds of input signals. You can project images from an external signal source just by connecting the equipment with the supplied cable and pushing the APA key.

- **Remote Commander with mouse control and laser pointer functions**

You can operate a computer with the Remote Commander since the unit has a build-in mouse receiver. For your presentation, you can use the laser pointer built in the Remote Commander as well.

Accepts various input signals

- **Scan converter loaded**

This projector has a build-in scan converter which converts the input signal within 1024 × 768 dots.

- **Compatible input signals**

This projector accepts video signals of the composite, S video, and component as well as the 15k RGB, VGA¹⁾, SVGA¹⁾, XGA¹⁾, and SXGA¹⁾ signals, which all can be displayed.

- **Compatible with five color systems**

NTSC, PAL, SECAM, NTSC_{4.43}²⁾, or PAL-M color system can be selected automatically or manually.

1) VGA, SVGA, XGA, and SXGA are registered trademarks of the International Business Machines Corporation, U.S.A.
 2) NTSC_{4.43} is the color system used when playing back a video recorded on NTSC on a NTSC_{4.43} system VCR.

Location and Function of Controls

Front/Left Side

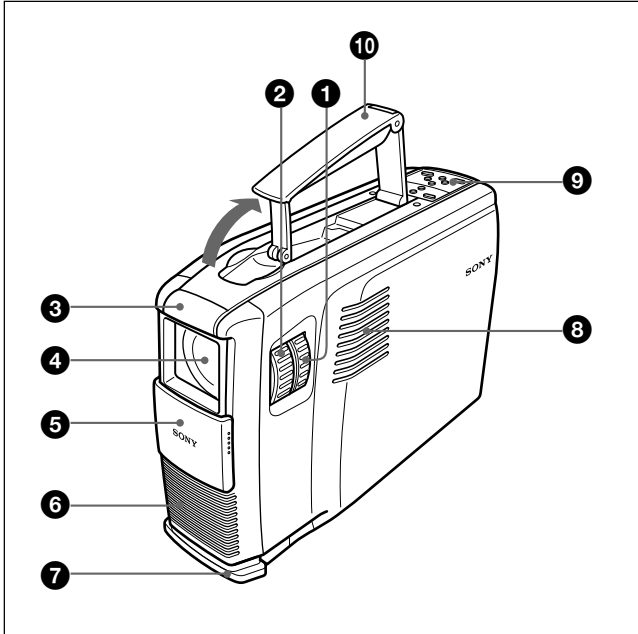

1 Zoom ring

Adjusts the size of the picture.

2 Focus ring

Adjusts the picture focus.

3 Front remote control detector (SIRCS receiver)

4 Lens

Open the lens shutter before projection.

5 Lens shutter

6 Ventilation holes (exhaust)

7 Adjuster

When a picture is projected on the out of the screen, adjust the picture using this adjuster.

For details on how to use the adjusters, see "How to use the adjuster" on page 9 (GB).

8 Left speaker

9 Control panel

For details, see "Control panel" on page 10 (GB).

10 Carrying handle

Pull up the handle from the projector for carrying.

Note

Be careful not to injure your fingers when you fold in the handle.

Rear/Right Side/Bottom

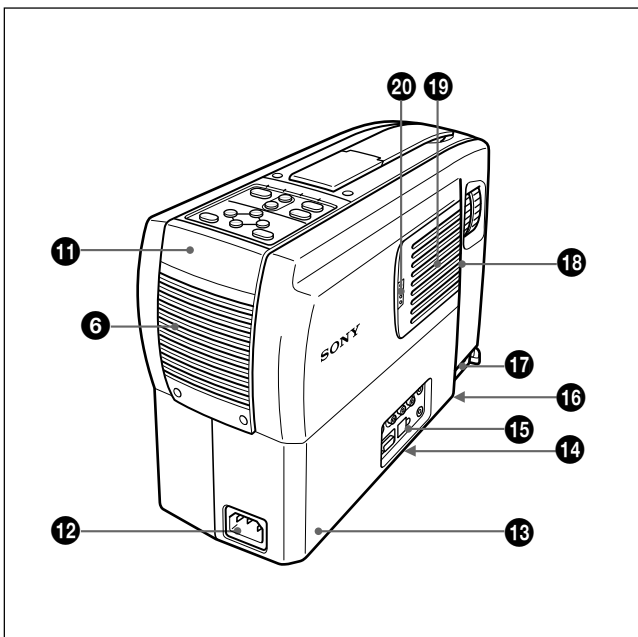

11 Rear remote control detector (SIRCS receiver)

12 AC IN socket

Connects the supplied AC power cord.

13 Security lock

Connects to an optional security cable (Kensington's).

The security lock corresponds to Kensington's MicroSaver Security System.

If you have any comment, contact

Kensington

2853 Campus Drive, San Mateo, CA 94403

U.S.A.

Tel: 800-535-4242: extension 3348

Home page address:

<http://www.kensington.com/>

14 75Ω termination switch (bottom)

Normally set to ON. Set it to OFF when the projector is connected to a computer or a monitor.

15 Connector panel

For details, see page 11 (GB).

16 Lamp cover (bottom)**17 Adjuster button****18 Right speaker****19 Ventilation holes (intake)/air filter cover****Notes**

- Do not place anything near the ventilation holes as it may cause internal heat build-up.
- Do not place your hand or objects near the ventilation holes — the air coming out is hot.

20 Air filter cover button

Used to remove the air filter cover.

For details, see "Cleaning the Air Filter" on page 25 (GB).

How to use the adjuster**To adjust the height**

Adjust the height of the projector as follows:

- 1** Lift the projector and press the adjuster button. The adjuster will extend from the projector.

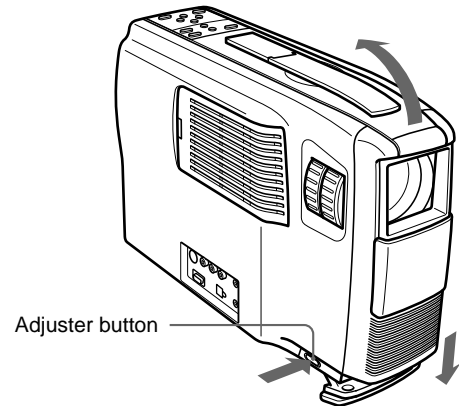

- 2** While pressing the button, lower the projector. Then, release the button.

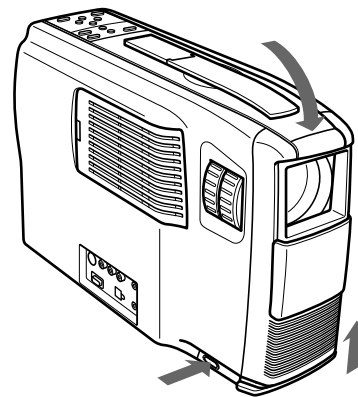
**Note**

The adjuster has 5 settings. After releasing the adjuster button, the height will be locked at next level.

Control panel

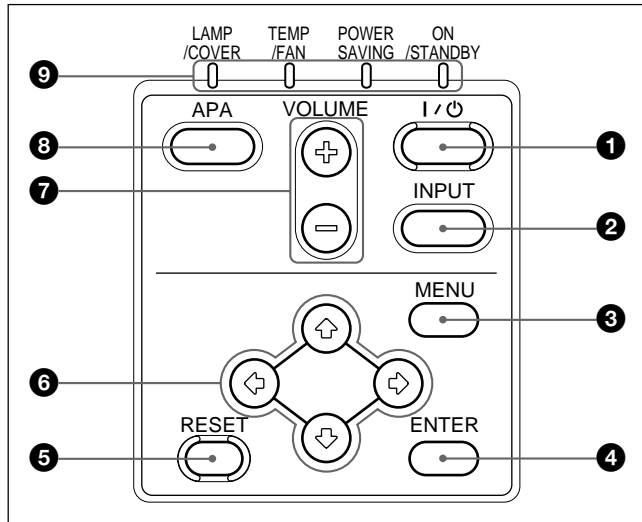

1 I / ⏻ (on / standby) key

Turns on and off the projector when the projector is in the standby mode. The ON/STANDBY indicator lights in green when the power is turned on.

When turning off the power, press the I / ⏻ key twice following the message on the screen, or press and hold the key for about one second.

For details on steps for turning off the power, see “To turn off the power” on page 18 (GB).

2 INPUT key

Selects the input signal. Each time you press the key, the input signal switches between video/audio input and INPUT A connector.

3 MENU key

Displays the on-screen menu. Press again to clear the menu.

4 ENTER key

Enters the settings of items in the menu system.

5 RESET key

Resets the value of an item back to its factory preset value. This key functions when the menu or a setting item is displayed on the screen.

6 Arrow keys (↑/↓/←/→)

Used to select the menu or to make various adjustments.

7 VOLUME +/- keys

Adjust the volume of the built-in speakers and output level of the AUDIO OUT jack.

- + : Increases the volume.
- : Decreases the volume.

8 APA (Auto Pixel Alignment) key

Adjusts a picture to be projected clearest automatically while a signal from the computer is input.

9 Indicators

LAMP/COVER: Lights up or flashes under the following conditions:

- Lights up when the lamp has reached the end of its life or becomes a high temperature.
- Flashes when the lamp cover or air filter cover is not secured firmly.

TEMP (Temperature)/FAN: Lights up or flashes under the following conditions:

- Lights up when temperature inside the projector becomes unusually high.
- Flashes when the fan is broken.

POWER SAVING: Lights up when the projector is in the power saving mode. When POWER SAVING in the SET SETTING menu is set to ON, the projector goes into the power saving mode if no signal is input for 10 minutes.

Although the lamp goes out, the cooling fan keeps running. In the power saving mode, any key does not function for the first 30 seconds. The power saving mode is canceled when a signal is input or any key is pressed.

ON/STANDBY: Lights up or flashes under the following conditions:

- Lights in red when the AC power cord is plugged into the wall outlet. Once in the standby mode, you can turn on the projector with the I / ⏻ key on the Remote Commander or on the control panel.
- Lights in green when the power is turned on.
- Flashes in green while the cooling fan runs after turning off the power with the I / ⏻ key. The fan runs for about 90 seconds after turning off the power. The ON/STANDBY indicator flashes quickly for the first 30 seconds. During this time, you cannot turn the power back on with the I / ⏻ key.

For details on the LAMP/COVER and the TEMP/FAN indicators, see page 27 (GB).

Connector panel

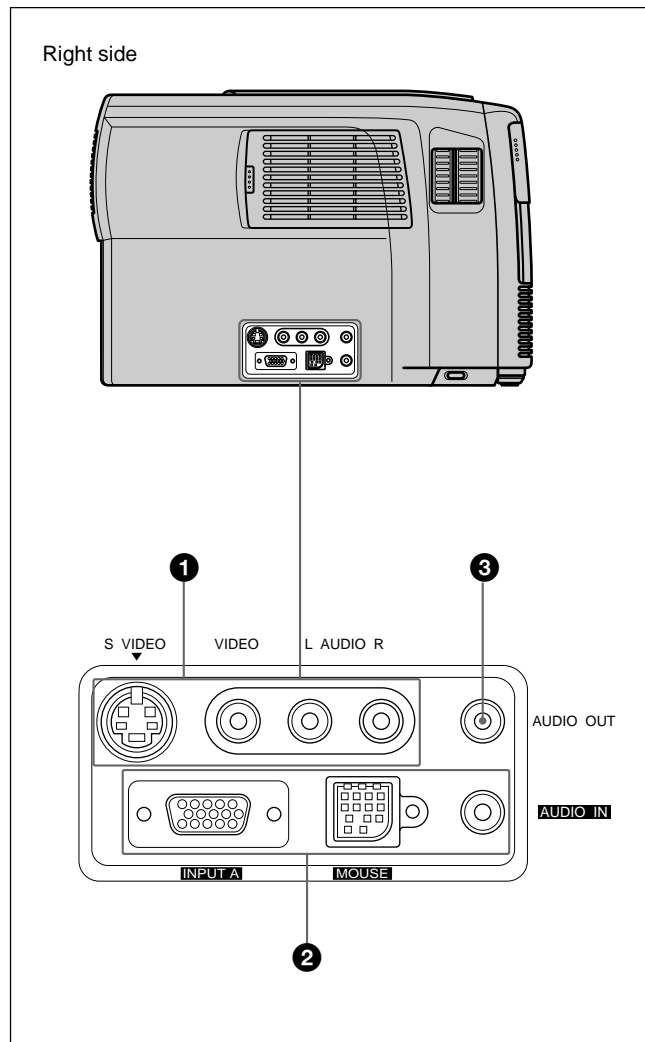

❶ Video/audio input connector

Connect to external video equipment such as a VCR.

S VIDEO (mini DIN 4-pin): Connects to the S video output (Y/C video output) of a video equipment.

VIDEO (phono type): Connects to the composite video output of video equipment.

Note

If you connect video equipment to both the S VIDEO and VIDEO jacks, the signal from the S VIDEO jack is selected. When projecting the picture via the VIDEO jack, be sure not to connect a cable to the S VIDEO jack.

AUDIO input L (MONO)/R jacks (phono type):

Connect to the audio output of equipment. For stereo equipment, use both the L and R jacks; for monaural equipment, use the L (MONO) jack only.

❷ INPUT A connector

Connect to external equipment such as a computer. You can control the mouse signal with the Remote Commander.

INPUT A (HD D-sub 15-pin, female): Connects to the monitor output on a computer using the supplied cable. When inputting a component or, 15k RGB signal, use the optional cable.

MOUSE (13-pin): Connects to the mouse port on a computer to control the mouse function using the supplied mouse cable.

AUDIO IN (stereo minijack): Connects to the audio output on a computer to input the audio signal.

❸ AUDIO OUT jack (stereo minijack)

Connects to external active speakers.

The volume of the speakers can be controlled by the VOLUME keys on the Remote Commander or the control panel.

Remote Commander

The keys which have the same names as on the control panel function identically.

You can control a connected computer using the Remote Commander.

For details, see "Connecting with a Computer" on page 14 (GB).

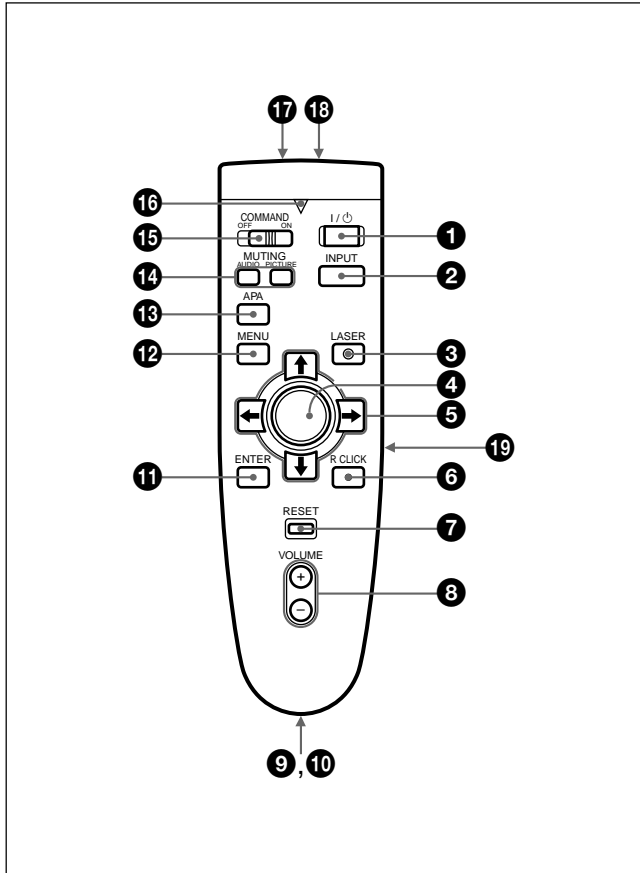

Notes on laser beam

- Do not look into the laser transmitter.
- Do not aim the laser at people.

① I / ⏻ key

② INPUT key

③ LASER key

Emits laser beam from the laser transmitter when you press this key.

④ Joy stick

Functions as a mouse of a computer connected to the unit.

⑤ Arrow keys (↑/↓/←/→)

⑥ R CLICK key

Functions as a right button on a mouse. When connected to a Macintosh¹⁾ computer, the R CLICK key functions as a mouse button.

⑦ RESET key

⑧ VOLUME +/- keys

⑨ Strap holder

Attaches the supplied strap.

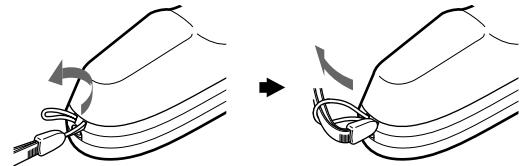

⑩ CONTROL S OUT jack (stereo minijack)

This jack does not operated with this unit.

Note

The Remote Commander does not function if the cable is connected to this jack.

⑪ ENTER key

⑫ MENU key

⑬ APA (Auto Pixel Alignment) key

⑭ MUTING keys

Cut off the picture and sound.

PICTURE: Cuts off the picture. Press again to restore the picture.

AUDIO: Cuts off the sound from speakers and AUDIO OUT jack. Press again or press the VOLUME + key to restore the sound.

⑮ COMMAND ON/OFF switch

When this switch is set to OFF, no key on the Remote Commander function. This saves the battery power.

⑯ Transmission indicator

Lights up when you press a key on the Remote Commander.

This indicator does not light up when you use the laser pointer.

⑰ Infrared transmitter

⑱ Laser transmitter

1) Macintosh is a registered trademark of Apple Computer, Inc.

19 L CLICK key

Functions as a left button on a mouse. When connected to a Macintosh computer, the L CLICK key functions as a mouse button.

Battery installation

- 1 Push and slide to open the lid, then install the two size AA (R6) batteries (supplied) with the correct polarity.

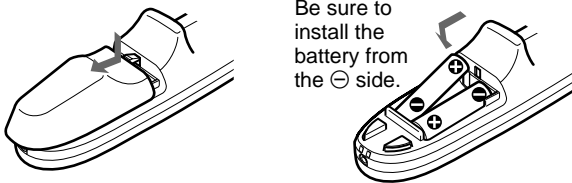

- 2 Replace the lid.

Notes on batteries

- Make sure that the battery orientation is correct when inserting batteries.
- Do not mix an old battery with a new one, or different types of batteries.
- If you will not use the Remote Commander for a long time, remove the batteries to avoid damage from battery leakage. If batteries have leaked, remove them, wipe the battery compartment dry and replace the batteries with new ones.

Notes on Remote Commander operation

- Make sure that there is nothing to obstruct the infrared beam between the Remote Commander and the remote control detector on the projector.
- The operation range is limited. The shorter the distance between the Remote Commander and the projector is, the wider the angle within which the commander can control the projector.

Installing the Projector

This section describes the installation arrangements for installing the projector.

Horizontal center
of the screen

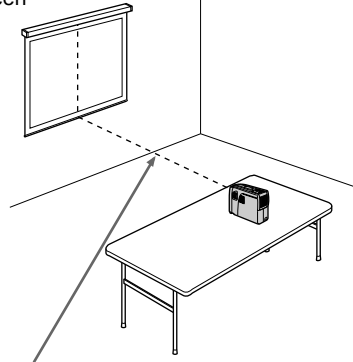

The distance between the lens and the screen varies depending on the size of the screen. Use the following table as a guide.

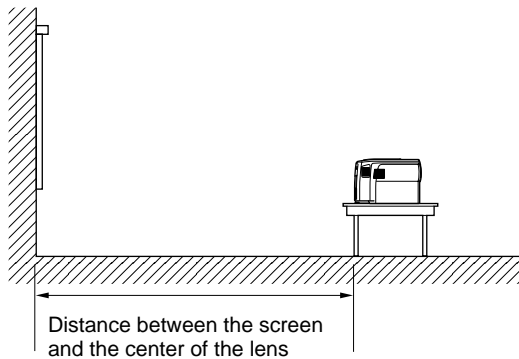

Distance between the screen
and the center of the lens

Unit: m (feet)

Screen size (inches)	40	60	80	100	120	150	200
Minimum Distance	1.6 (5.2)	2.4 (8.0)	3.3 (10.8)	4.1 (13.5)	5.0 (16.3)	6.2 (20.4)	8.3 (27.4)
Maximum Distance	2.0 (6.7)	3.1 (10.2)	4.2 (13.7)	5.2 (17.1)	6.3 (20.6)	7.9 (25.8)	10.5 (34.5)

Note

You can not install the projector upside down, such as on a ceiling.

Connecting

Connecting with a Computer

This section describes how to connect the projector with a computer.

For details on how to connect a VCR, 15k RGB, or component equipment, see page 16 (GB).

When the projector is connected to a computer, you can control the mouse of a computer by the Remote Commander.

The R/L CLICK keys and joy stick function as follows.

Note

Make sure that there is nothing to obstruct the infrared beam between the Remote Commander and the remoter control detector on the projector.

Key and joy stick	Function	
	IBM PC/AT ^{a)} compatible, Serial	Macintosh
R CLICK (front)	Right button	Mouse button
L CLICK (rear)	Left button	Mouse button
Joy stick	Corresponds with the movements of the mouse	

a) IBM PC/AT is a registered trademark of International Business Machines Corporation, U.S.A.

Also refer to the instruction manual of equipment to be connected.

Notes

- This unit accepts the VGA, SVGA, XGA, and SXGA signals. However, we recommend you to set the output mode of your computer to the XGA mode for the external monitor.
- If you set your computer, such as a notebook type IBM PC/AT compatible, to output the signal to both the display of your computer and the external monitor, the picture of the external monitor may not appear properly. In such cases, set the output mode of your computer to output the signal to only the external monitor.

For details, refer to the operating instructions supplied with your computer.

When making connections, be sure to:

- turn off all equipment before making any connections.
- use the proper cables for each connection.
- insert the plugs of the cables properly; plugs that are not fully inserted often generate noise. When pulling out a cable, be sure to pull it out from the plug, not the cable itself.

Note

Supplied mouse cables may not work properly according to your computer.

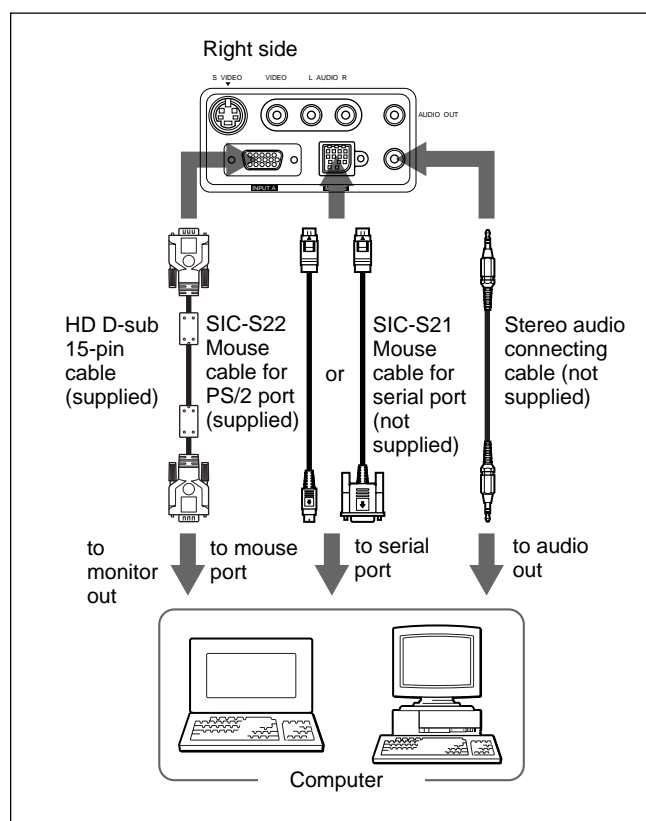
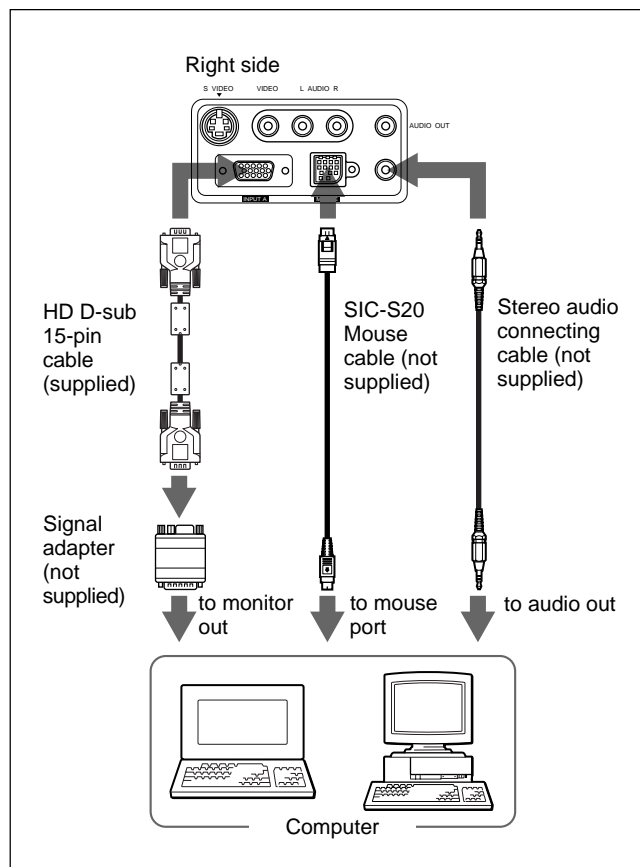
When connecting with an IBM PC/AT compatible computer**When connecting with a Macintosh computer**

Connecting with a VCR/15k RGB/Component Equipment

This section describes how to connect the projector with a VCR, external active speakers, and 15k RGB/component equipment.

For details on how to connect a computer, see page 14 (GB).

Also refer to the instruction manuals of the equipment to be connected.

When making connections, be sure to:

- turn off all equipment before making any connections.
- use the proper cables for each connection.
- insert the plugs of the cables properly; plugs that are not fully inserted often generate noise. When pulling out a cable, be sure to pull it out from the plug, not the cable itself.

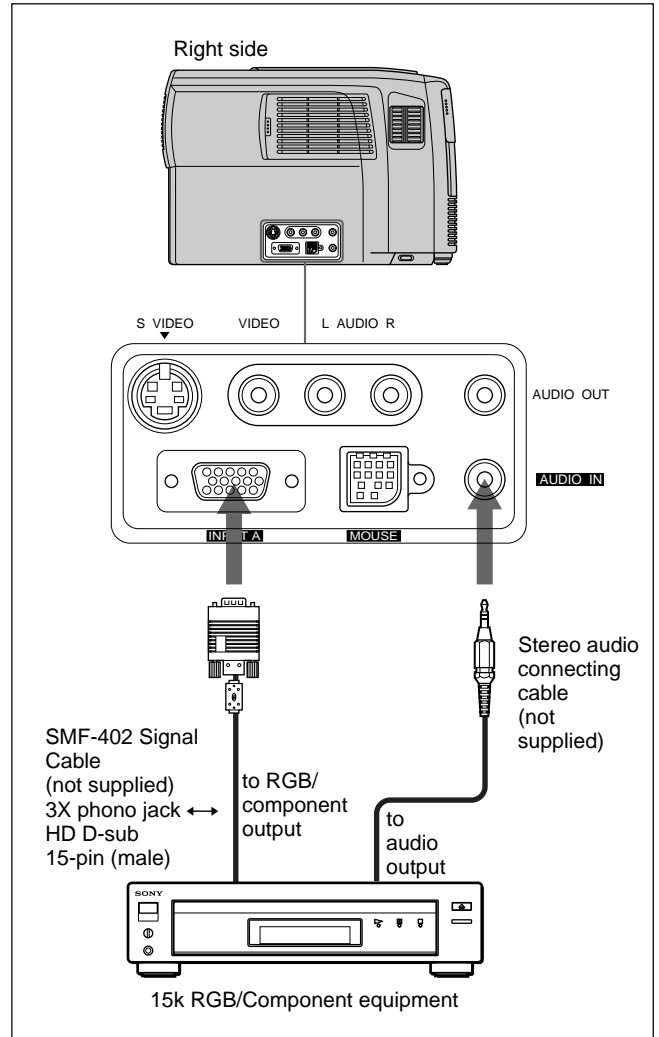
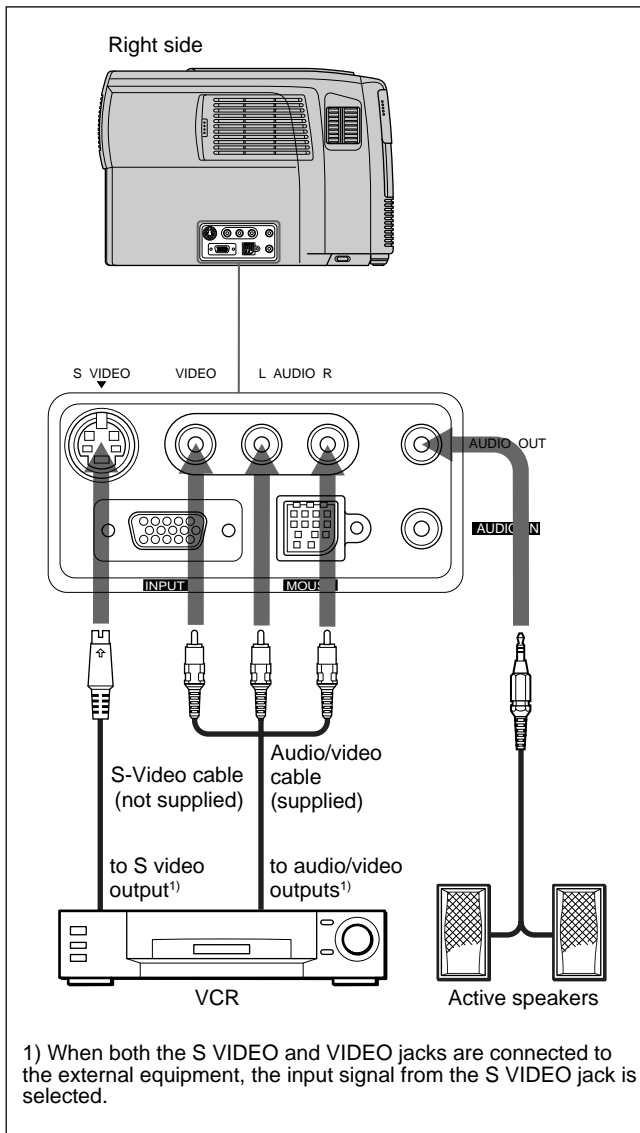

Notes

- Set the aspect ratio using ASPECT in the INPUT SETTING menu according to the input signal.
- When you connect the unit to 15k RGB/component video equipment, select RGB or component with the INPUT-A setting in the SET SETTING menu.
- Use the composite sync signal when you input the external sync signal from 15k RGB/component equipment.

Projecting

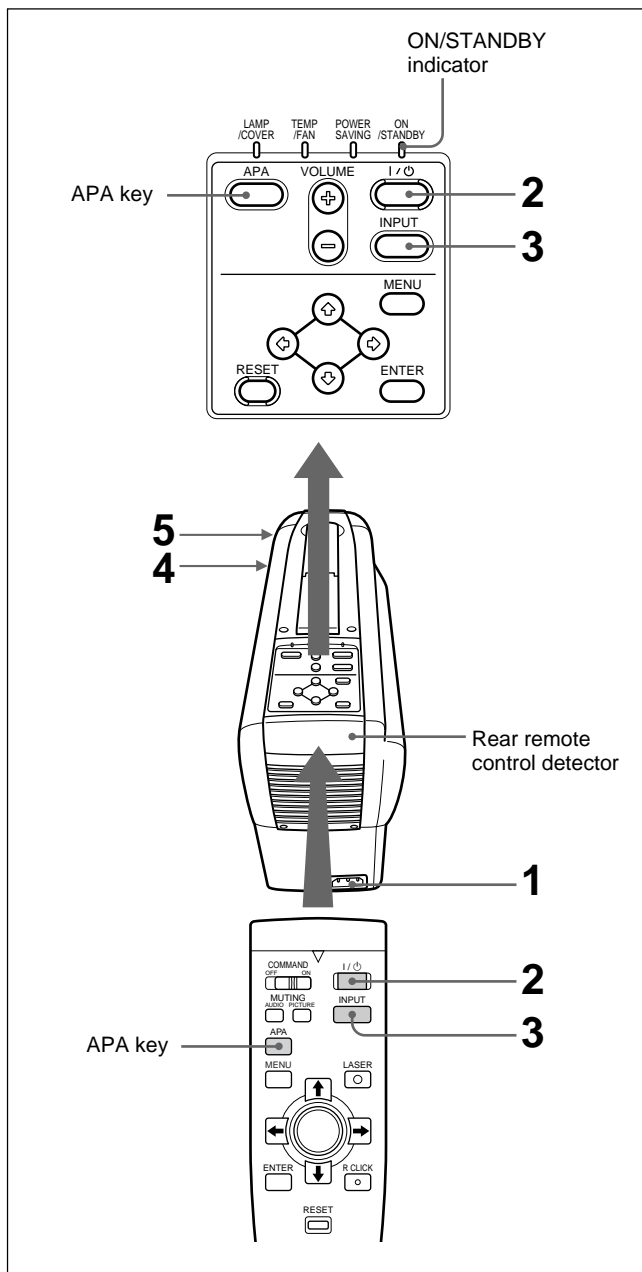

- 1** After all equipment is connected completely, plug the AC power cord into the wall outlet.
The ON/STANDBY indicator lights in red and the projector goes into the standby mode.
- 2** Press the I / ⏻ key on the Remote Commander or on the control panel.
The ON/STANDBY indicator lights in green.
- 3** Turn on equipment connected to the projector. Press the INPUT key on the Remote Commander or on the control panel to select the input source.

INPUT-A: Selects audio and video signals input from the INPUT A connector.

VIDEO: Selects audio and video signals input from the video/audio input connector. (If you connect to both the S VIDEO and VIDEO jacks, the signal from the S VIDEO jack is selected.)

- 4** Turn the zoom ring to adjust the size of the picture.
- 5** Turn the focus ring to adjust the focus.

Note

Looking into the lens when projecting may cause injury to your eyes.

To	Press
Adjust the volume	the VOLUME +/- keys on the control panel or on the Remote Commander.
Cut off the sound	the AUDIO MUTING key on the Remote Commander. To restore the sound, press the AUDIO MUTING key again or press the VOLUME + key.
Cut off the picture	the PICTURE MUTING key on the Remote Commander. To restore the picture, press the PICTURE MUTING key again.

To get the clearest picture

You can get the suitable picture when a signal from the computer is input. Press the APA key on the Remote Commander or on the control panel. The picture is automatically adjusted to be projected clearest.

Notes

- Adjust the signal when the still picture is displayed on the screen.
- If you switch the input signal or re-connect a computer, press the APA key again to get the suitable picture.
- “ADJUSTING” appears on the screen. Press the APA key again during the adjustment to restore the original screen.
- “Complete!” appears on the screen when the picture is adjusted properly. The picture may not be adjusted properly depending on the kinds of input signals.
- Adjust DOT PHASE in the INPUT SETTING menu when you adjust the picture manually.
For details on DOT PHASE, see page 21 (GB).

To turn off the power

- 1 Press the I / ⏻ key on the Remote Commander or on the control panel.

The following message appears to confirm if you want to turn off the power.

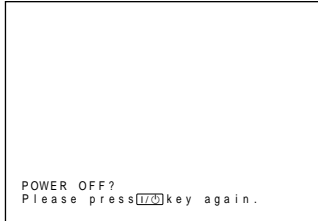

Note

The message will disappear if you press any key except the I / ⏻ key, or if you do not press any key for five seconds.

- 2 Press the I / ⏻ key on the Remote Commander or on the control panel again.

The ON/STANDBY indicator flashes in green and the fan continues to run for about 90 seconds to reduce the internal heat. Also, the ON/STANDBY indicator flashes quickly for the first 30 seconds. During this time, you will not be able to turn the power back on with the I / ⏻ key.

- 3 Unplug the AC power cord from the wall outlet after the fan stops running and the ON/STANDBY indicator lights in red.

When you cannot confirm the on-screen message

When you cannot confirm the on-screen message in a certain condition, you can turn off the power by holding the I / ⏻ key on the Remote Commander or on the control panel for about one second.

Note

Do not unplug the AC power cord while the fan is still running; otherwise, the fan will stop although the internal heat is still high, leading to breakdown of the projector.

Using the MENU

The projector is equipped with an on-screen menu for making various adjustments and settings.

To select the language used in the menu, see page 23 (GB).

- 1 Press the MENU key.
The menu display appears.
The menu presently selected is highlighted in blue.

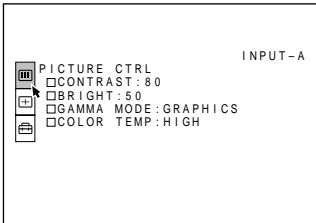

- 2 Use the **↑** or **↓** key to select a menu, then press the **→** or ENTER key.
The selected menu appears.

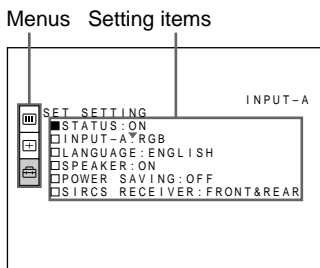

- 3 Make setting or adjustment on an item.
For details on setting individual items, see the relevant menu pages.

To clear the menu display

Press the MENU key.
The menu display disappears automatically if no key is pressed for one minute.

To reset items that have been adjusted

Press the RESET key.
“Complete!” appears on the screen and the settings appearing on the screen will be reset to their factory preset values.

Items which can be reset are:

- “CONTRAST”, “BRIGHT”, “COLOR”, “HUE”, and “SHARP” in the PICTURE CTRL menu
- “DOT PHASE”, “SIZE”, and “SHIFT” in the INPUT SETTING menu.

About the memory of the settings

The settings are automatically stored in the projector memory.

When no signal is input

When there is no input signal, “NO INPUT—Cannot adjust this item.” appears on the screen, and each item cannot be adjusted.

The PICTURE CTRL Menu

The PICTURE CTRL (control) menu is used for adjusting the picture.

Unadjustable items depending on the input signal are not displayed in the menu.

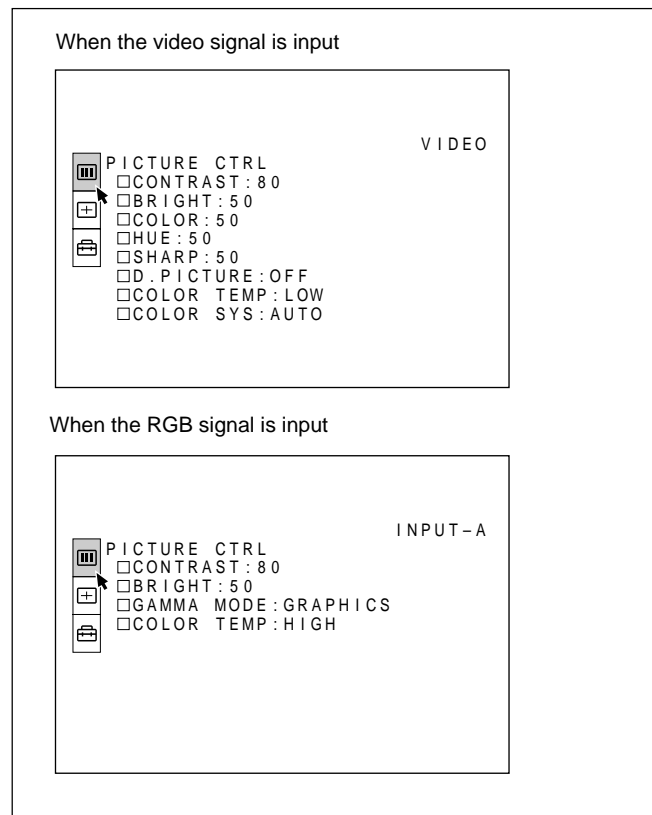

Operation

1. Select an item

Use the **↑** or **↓** key to select the item, then press the **→** or ENTER key.

2. Adjust an item

- When changing the adjustment level:
To increase the number, press the **↑** or **→** key.

(Continued)

To decrease the number, press the ↓ or ← key.
Press the ENTER key to restore the original screen.

- When changing the setting:
Press the ↑ or ↓ key to change the setting.
Press the ENTER or ← key to restore the original screen.

CONTRAST

Adjusts the picture contrast.
The higher the setting, the greater the contrast.
The lower the setting, the lower the contrast.

BRIGHT

Adjusts the picture brightness.
The higher the setting, the brighter the picture.
The lower the setting, the darker the picture.

COLOR

Adjusts color intensity.
The higher the setting, the greater the intensity.
The lower the setting, the lower the intensity.

HUE

Adjusts color tones.
The higher the setting, the picture becomes greenish.
The lower the setting, the picture becomes purplish.

SHARP

Adjusts the picture sharpness.
The higher the setting, the sharper the picture.
The lower the setting, the softer the picture.

D. (Dynamic) PICTURE

Emphasizes the black color.
ON: Emphasizes the black color to produce a bolder “dynamic” picture.
OFF: Reproduces the dark portions of the picture accurately, in accordance with the source signal.

GAMMA MODE

Selects a gamma correction curve.

GRAPHICS: Improves the reproduction of half tones. Photos can be reproduced in natural tones.

TEXT: Contrasts black and white. Suitable for images that contains lots of text.

COLOR TEMP

Adjusts the color temperature.

HIGH: Makes the white color bluish.

LOW: Makes the white color reddish.

COLOR SYS (System)

Selects the color system of the input signal.

Normally, set to AUTO.

If the picture is distorted or colorless, select the color system according to the input signal.

Input signals and adjustable/setting items

Item	Input signal			
	Video or S video (Y/C)	Component	RGB	B&W
CONTRAST	●	●	●	●
BRIGHT	●	●	●	●
COLOR	●	●	–	–
HUE	● (NTSC3.58/ 4.43 only)	–	–	–
SHARP	●	●	–	●
D. PICTURE	●	●	–	●
GAMMA MODE	–	–	●	–
COLOR TEMP	●	●	●	●
COLOR SYS	●	–	–	●

● : Adjustable/can be set

– : Not adjustable/can not be set

The INPUT SETTING Menu

The INPUT SETTING menu is used to adjust the input signal.

Unadjustable items depending on the input signal are not displayed in the menu.

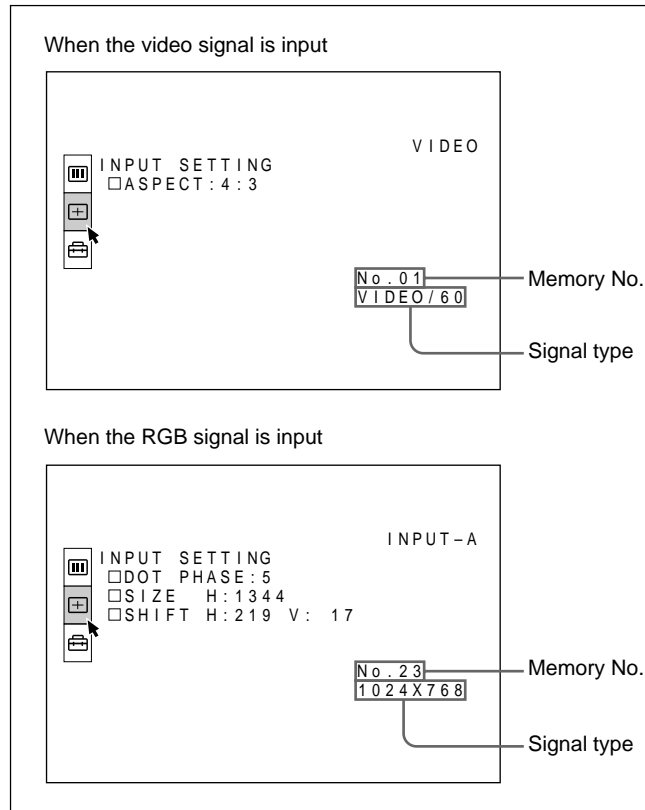

Operation

1. Select an item

Use the \uparrow or \downarrow key to select the item, then press the \rightarrow or ENTER key.

2. Adjust an item

- When changing the adjustment level:
 - To increase the number, press the \uparrow or \rightarrow key.
 - To decrease the number, press the \downarrow or \leftarrow key.
 - Press the ENTER key to restore the original screen.
- When changing the setting:
 - Press the \uparrow or \downarrow key to change the setting.
 - Press the ENTER or \leftarrow key to restore the original screen.

DOT PHASE

Adjusts the dot phase of the LCD panel and the signal input from the INPUT A connector. Adjust the picture further for finer picture after the picture is adjusted with pressing the APA key.

Adjust the picture to where it looks clearest.

SIZE

Adjusts the horizontal size of picture input from the INPUT A connector.

The higher the setting, the larger the horizontal size of the picture.

The lower the setting, the smaller the horizontal size of the picture. Adjust the setting according to the dots of the input signal. For details on the suitable value for the preset signals, see page 22 (GB).

SHIFT

Adjusts the position of the picture input from the INPUT A connector.

H adjusts the horizontal position of the picture.

V adjusts the vertical position of the picture.

As the setting for H increases, the picture moves to the right, and as the setting decreases, the picture moves to the left.

As the setting for V increases, the picture moves up, and as the setting decreases, the picture moves down.

Use the \leftarrow or the \rightarrow key to adjust the horizontal position and the \uparrow and \downarrow key for the vertical position.

ASPECT

Sets the aspect ratio of the picture.

When inputting 16:9 (squeezed) signal from equipment such as a DVD player, set to 16:9.

4:3: When the picture with ratio 4:3 is input.

16:9: When the picture with ratio 16:9 (squeezed) is input.

SCAN CONV (Scan converter)

Converts the signal to display the picture according to the screen size.

ON: Displays the picture according to the screen size. The picture will lose some clarity.

OFF: Displays the picture while matching one pixel of input picture element to that of the LCD. The picture will be clear but the picture size will be smaller.

Note

When the XGA or SXGA signal is input, this item will not be displayed.

(Continued)

Input signals and adjustable/setting items

Item	Input signal			
	Video or S video (Y/C)	15k RGB/Component	RGB	B&W
DOT PHASE	–	–	●	–
SIZE	–	–	●	–
SHIFT	–	–	●	–
ASPECT	●	●	–	●
SCAN CONV	–	–	●	–

● : Adjustable/can be set

– : Not adjustable/can not be set

About the preset memory No.

This projector has 37 kinds of preset data for input signals for INPUT-A (the preset memory). The memory number of the current input signal and the signal type are displayed when the preset signal is input. This projector automatically detects the signal type. When the signal is registered to the preset memory, a suitable picture is displayed on the screen according to the signal type. You can adjust the picture through the INPUT SETTING menu.

This projector also has 20 kinds of user memories for INPUT-A. When an unpreset signal is input for the first time, memory number is displayed as 00. If the input signal is adjusted in the INPUT SETTING menu, the setting via INPUT-A is stored under the memory number 51 to 70. When more than 20 user memories are registered for INPUT-A, the newest memory is automatically stored over the oldest one.

Preset signals

Memory No.	Preset signal	fH (kHz)	fV (Hz)	Sync	SIZE	
1	Video 60 Hz	15.734	59.940	H-neg V-neg		
2	Video 50 Hz	15.625	50.000	H-neg V-neg		
3	15k RGB/Component 60 Hz	15.734	59.940	H-neg V-neg		
4	15k RGB/Component 50 Hz	15.625	50.000	H-neg V-neg		
6	640 × 350	VGA mode 1	31.469	70.086	H-pos V-neg	800
7		VGA VESA ^{a)} 85 Hz	37.861	85.080	H-pos V-neg	832
8	640 × 400	PC-9801 ^{b)} Normal	24.823	56.416	H-neg V-neg	848
9		VGA mode 2	31.469	70.086	H-neg V-pos	800
10		VGA VESA 85 Hz	37.861	85.080	H-neg V-pos	832
11	640 × 480	VGA mode 3	31.469	59.940	H-neg V-neg	800
12		Macintosh 13"	35.000	66.667	H-neg V-neg	864
13		VGA VESA 72 Hz	37.861	72.809	H-neg V-neg	832
14		VGA VESA 75 Hz	37.500	75.000	H-neg V-neg	840
15		VGA VESA 85 Hz	43.269	85.008	H-neg V-neg	832
16		800 × 600	SVGA VESA 56 Hz	35.156	56.250	H-pos V-pos
17	SVGA VESA 60 Hz		37.879	60.317	H-pos V-pos	1056
18	SVGA VESA 72 Hz		48.077	72.188	H-pos V-pos	1040
19	SVGA VESA 75 Hz		46.875	75.000	H-pos V-pos	1056
20	SVGA VESA 85 Hz		53.674	85.061	H-pos V-pos	1048
21	832 × 624	Macintosh 16"	49.724	74.550	H-neg V-neg	1152
22	1024 × 768	XGA VESA 43 Hz	35.522	43.479	H-pos V-pos	1264
23		XGA VESA 60 Hz	48.363	60.004	H-neg V-neg	1344
24		XGA VESA 70 Hz	56.476	70.069	H-neg V-neg	1328
25		XGA VESA 75 Hz	60.023	75.029	H-pos V-pos	1312
26		XGA VESA 85 Hz	68.677	84.997	H-pos V-pos	1376
27	1152 × 864	SXGA VESA 70 Hz	63.995	70.016	H-pos V-pos	1472
28		SXGA VESA 75 Hz	67.500	75.000	H-pos V-pos	1600
29		SXGA VESA 85 Hz	77.487	85.057	H-pos V-pos	1568
30	1152 × 900	Sunmicro LO	61.795	65.960	H-neg V-neg	1504
31		Sunmicro HI	71.713	76.047	H-neg V-neg	1472
32	1280 × 960	SXGA VESA 60 Hz	60.000	60.000	H-pos V-pos	1800
33		SXGA VESA 75 Hz	75.000	75.000	H-pos V-pos	1728
34	1280 × 1024	SXGA VESA 43 Hz	46.433	43.436	H-pos V-pos	1696
35		SXI-5	53.316	50.062	H-neg V-neg	1680
36		SXGA VESA 60 Hz	63.974	60.013	H-pos V-pos	1696
37		SXGA VESA 75 Hz	79.976	75.025	H-pos V-pos	1688
38		SXGA VESA 85 Hz	91.146	85.024	H-pos V-pos	1296

a) VESA is a registered trademark of Video Electronics Standard Association.

b) PC-98 is a registered trademark of NEC Corporation.

Since the data is recalled from the preset memory about the following signals, you can use these preset data by adjusting SIZE. Make fine adjustment by adjusting SHIFT.

Signal	Memory No.	SIZE
Super Mac-2	23	1312
SGL-1	23	1320
Macintosh 19"	25	1328
Macintosh 21"	28	1456
Sony News	36	1708
PC-9821 1280 × 1024	36	1600
WS Sunmicro	37	1664

Note

When the aspect ratio of input signal is other than 4:3, a part of the screen is displayed in black.

The SET SETTING Menu

The SET SETTING menu is used for changing the settings of the projector.

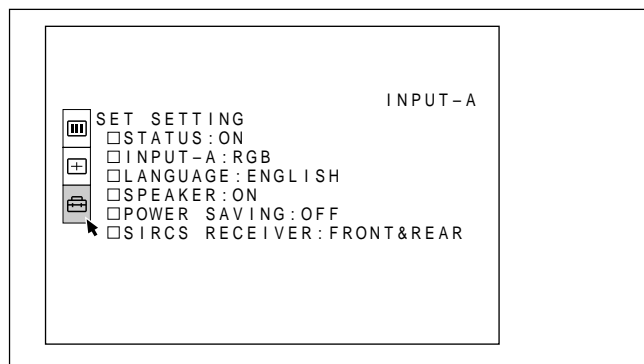

Operation

1. Select an item

Use the **↑** or **↓** key to select the item, then press the **→** or ENTER key.

2. Change the setting

Press the **↑** or **↓** key to change the setting. To restore the original screen, press the ENTER or **←** key.

STATUS (on-screen display)

Sets up the on-screen display.

ON: Shows all of the on-screen displays.

OFF: Turns off the on-screen displays except for the menus, a message when turning off the power, and warning messages.

For details on the warning messages, see page 27 (GB).

INPUT-A

Selects the RGB or component signal input from the INPUT A connector.

Note

If the setting is not correct, “Please check INPUT-A in SET SETTING.” appears on the screen and the color of the picture becomes strange or the picture is not displayed.

LANGUAGE

Selects the language used in the menu and on-screen displays.

Available languages are: English, French, German, Italian, Spanish, Japanese and Chinese.

SPEAKER

Set to OFF to cut off the sound of the internal speakers. When set to OFF, “SPEAKER OFF” appears on the screen when you turn on the power.

POWER SAVING

When set to ON, the projector goes into the power saving mode if no signal is input for 10 minutes.

SIRCS RECEIVER

Selects the remote control detectors (SIRCS receiver) on the front and rear of the projector.

FRONT & REAR: Activates both the front and rear detectors.

FRONT: Activates the front detector only.

REAR: Activates the rear detector only.

Maintenance

Replacing the Lamp

When it is time to replace the lamp, replace the lamp promptly with a new LMP-P120 Projector Lamp.

When replacing the lamp after using the projector

Turn off the projector, then unplug the power cord. Wait for at least an hour for the lamp to cool.

Note

The lamp becomes a high temperature after turning off the projector with the I / ⏻ key. If you touch the lamp, you may scald your finger. When you replace the lamp, wait for at least an hour for the lamp to cool.

- 1 Place a protective sheet (cloth) beneath the projector. Tilt the projector 90 degrees backward so you can see the bottom.

Note

Be careful not to topple over the projector after turning it over.

- 2 Press the adjuster button. The adjuster will extend from the projector.

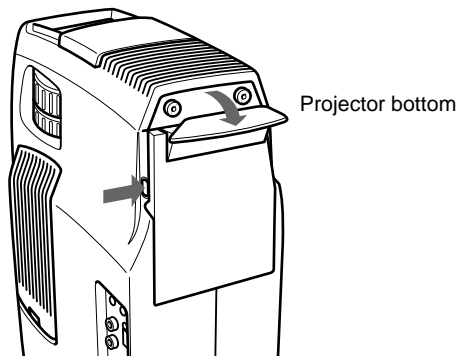

- 3 Open the lamp cover that is a part of the adjuster by loosening two screws with the Philips screwdriver (supplied with the LMP-P120 Projector Lamp).

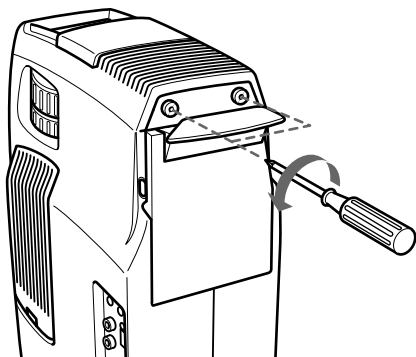

Note

For safety sake, do not loosen any other screws.

- 4 Loosen the screw on the lamp unit with the Philips screwdriver. Pull out the lamp unit by the handle.

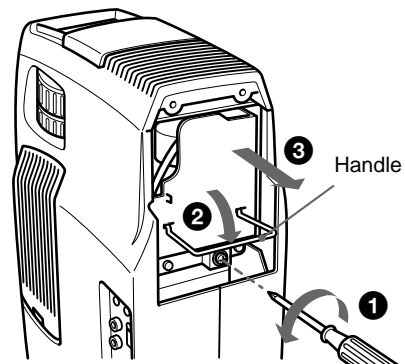

- 5 Insert the new lamp all the way in until it is securely in place. Tighten the screw. Fold up the handle.

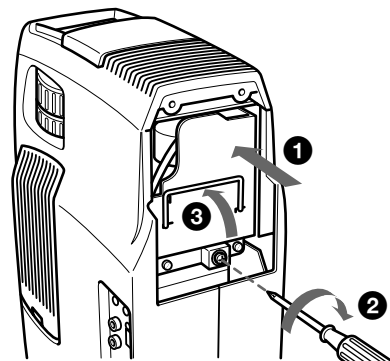

Notes

- Be careful not to touch the glass surface of the lamp.
- The power will not turn on if the lamp is not secured properly.

- 6 Close the lamp cover and tighten the screws.
- 7 Turn the adjuster inward and push it back.
- 8 Turn the projector back over.
- 9 Connect the power cord and turn the projector to the standby mode.
- 10 Press the following keys on the control panel in the following order for less than in five seconds each: RESET, ←, →, ENTER.

Notes

- Be sure to use the LMP-P120 Projector Lamp for replacement. If you use lamps other than LMP-P120, the projector may cause a malfunction.
- Be sure to turn off the projector and unplug the power cord before replacing the lamp.
- Do not put your hands into the lamp replacement spot, or not fall any liquid or object into it to avoid electrical shock or fire.

Cleaning the Air Filter

The air filter should be cleaned every 300 hours. When it becomes difficult to remove the dust from the filter, replace the filter with a new one.

To clean the air filter, follow the steps below:

- 1** Turn off the power and unplug the power cord.
- 2** While holding down the air filter cover button on the filter cover, slide the cover toward the lens to remove it.

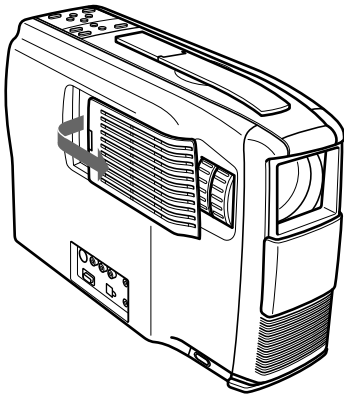

- 3** Pull up the spring.

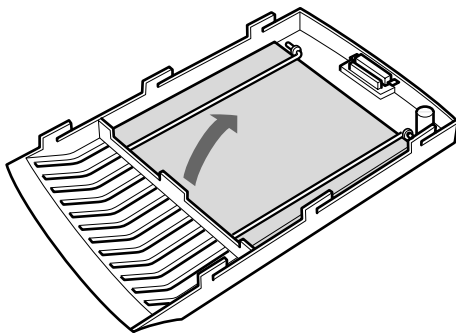

- 4** Remove the air filter.

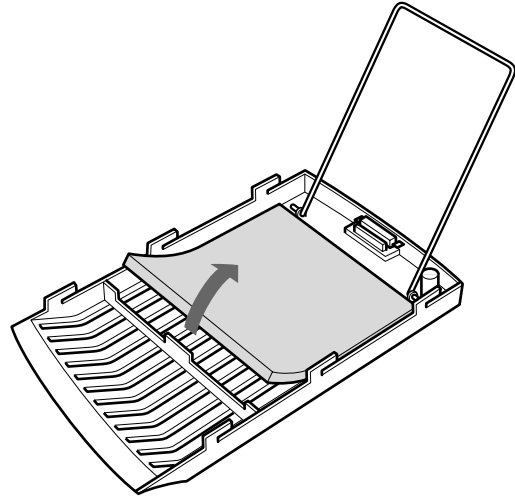

- 5** Remove the dust from the filter with a vacuum cleaner.
- 6** Attach the air filter and replace the cover.

Troubleshooting

If the projector appears to be operating erratically, try to diagnose and correct the problem, using the following guide. If the problem still persists, consult with qualified Sony personnel.

Symptom	Cause	Remedy
The power is not turned on.	The power has been turned off and on with the I / ⏻ key at a short interval.	Wait for about 90 seconds before turning on the power (see page 17 (GB)).
	The lamp cover is detached.	Close the lamp cover securely (see page 24 (GB)).
	The air filter cover is detached.	Close the air filter cover securely (see page 25 (GB)).
No picture and no sound.	Cable is disconnected.	Check that the proper connections have been made (see pages 14 (GB) to 16 (GB)).
	Wrong connection.	Check that the proper connections have been made (see pages 14 (GB) to 16 (GB)).
	Input selection is incorrect.	Select the input source correctly using the INPUT key (see page 17 (GB)).
No picture or no sound.	Either the picture or the sound is cut off.	Press the MUTING keys to release the muting function (see page 17 (GB)).
No picture.	The computer signal is not set to output to external monitor.	Set the computer signal to output to external monitor (see page 14 (GB)).
	The computer signal is set to output to both the LCD of the computer and external monitor.	Set the computer signal to output only to external monitor (see page 14 (GB)).
The picture is noisy.	Noise may appear on the background depending on the combination of the numbers of dot input from the connector and numbers of pixel on the LCD panel.	Change the desktop pattern on the connected computer.
When inputting sound through INPUT A connector, sound comes through one channel only.	Monaural sound is being input through the INPUT A connector.	Input stereo sound.
The picture input from the INPUT A connector is too bright.	The 75-ohm termination switch on the bottom of the VPL-PX1 is set to OFF.	Set the 75-ohm termination switch to ON.
The picture from INPUT A connector is colored strange.	Setting for INPUT-A in the SET SETTING menu is incorrect.	Select RGB or COMPONENT for INPUT-A in the SET SETTING menu according to the input signal (see page 23 (GB)).
"Please check INPUT-A in SET SETTING." appears in spite of inputting the correct signal from INPUT A.	Setting for INPUT-A in the SET SETTING menu is incorrect.	Select RGB or COMPONENT for INPUT-A in the SET SETTING menu according to the input signal (see page 23 (GB)).
On-screen display do not appear.	STATUS in the SET SETTING menu has been set to OFF.	Set STATUS in the SET SETTING menu to ON (see page 23 (GB)).
Color balance is incorrect.	Picture has not been adjusted properly.	Adjust the picture (see pages 19 (GB) and 20 (GB)).
	Projector is set to wrong color system.	Set COLOR SYS in the PICTURE CTRL menu to match the color system being input (see page 20 (GB)).
The picture is too dark.	Contrast or brightness has not been adjusted properly.	Adjust the contrast or brightness in the PICTURE CTRL menu properly (see page 20 (GB)).
The picture is not clear.	Picture is out of focus.	Adjust the focus (see page 17 (GB)).
	Condensation has occurred on the lens.	Leave the projector for about two hours with the power on (see page 28 (GB)).

Symptom	Cause	Remedy
The LAMP/COVER indicator flashes.	The lamp cover or the air filter cover is detached.	Attach the cover securely (see pages 24 (GB) and 25 (GB)).
The LAMP/COVER indicator lights up.	The lamp has reached the end of its life.	Replace the lamp (see page 24 (GB)).
	The lamp becomes a high temperature.	Wait for 90 seconds to cool down the lamp and turn on the power again (see page 17 (GB)).
The TEMP/FAN indicator flashes.	The fan is broken.	Consult with qualified Sony personnel.
The TEMP/FAN indicator lights up.	The internal temperature is unusually high.	Check to see if nothing is blocking the ventilation holes.
The Remote Commander does not work.	The Remote Commander batteries are dead.	Replace with new batteries (see page 13 (GB)).
	The COMMANDER ON/OFF switch is set to the OFF position.	Set the switch to ON position (see page 12 (GB)).
	The cable is connected to the CONTROL S OUT jack.	Disconnect the cable (see page 12 (GB)).
	The front/rear remote control detector is near the fluorescent lamp.	Change the setting of SIRCS RECEIVER in the SET SETTING menu (see page 23 (GB)).
The laser pointer is not emitted.	The batteries are dead.	Replace with new batteries (see page 13 (GB)).
	The Remote Commander is used as wired without batteries.	Install batteries (see page 13 (GB)).
The joystick, R CLICK, or L CLICK key does not function.	The mouse port on the computer does not recognize the mouse cable.	Restart the computer.

Warning messages

Use the list below to check the meaning of the messages displayed on the screen.

Message	Meaning	Remedy
High Temperature! Power off in 1 min.	Internal temperature is too high.	Turn off the power. Check to see if nothing is blocking the ventilation holes.
Frequency is out of range!	This input signal cannot be projected as the frequency is out of the acceptable range of the projector.	Input a signal that is within the range of the frequency.
	The resolution setting of the output signal of a computer is too high.	Set the setting of output to the XGA (see page 14 (GB)).
Please check INPUT-A in SET SETTING.	You have input RGB signal from the computer when INPUT-A in the SET SETTING menu is set to COMPONENT.	Set INPUT-A correctly (see page 23 (GB)).

Caution messages

Use the list below to check the meaning of the messages displayed on the screen.

Message	Meaning	Remedy
NO INPUT	No input signal	Check connections (see page 14 (GB) to 16 (GB)).
Not applicable!	You have pressed the wrong key.	Press the appropriate key.

Tips for Installation

Unsuitable Installation

Do not install the projector in the following situations. These installations may cause malfunction or damage to the projector.

Poorly ventilated



- Allow adequate air circulation to prevent internal heat build-up. Do not place the unit on surfaces (rugs, blankets, etc.) or near materials (curtains, draperies) that may block the ventilation holes. When the internal heat builds up due to the block-up, the temperature sensor will function with the message “High Temperature! Power off in 1 min.” The power will be turned off automatically after one minute.
- Leave space of more than 30 cm (11 7/8 inches) around the unit.
- Be careful that the ventilation holes may inhale tininess such as a piece of paper.

Highly heated and humid

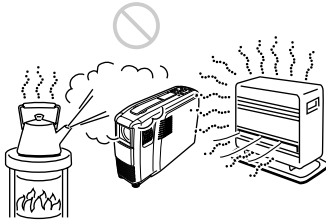

- Avoid installing the unit in a location where the temperature or humidity is very high, or temperature is very low.
- To avoid moisture condensation, do not install the unit in a location where the temperature may rise rapidly.

Very dusty



Avoid installing the unit in a location where there is a lot of dust; otherwise, the air filter will be obstructed. The dust blocking the air through the filter may cause raising the internal heat of the projector. Clean it up periodically.

Notes on Installation

Carry out the followings.

No toppling of the unit

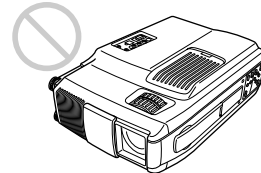

Avoid using as the unit topples over on its side. It may cause malfunction.

Use to be level

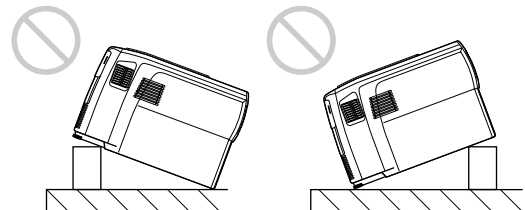

Do not install the unit other than on the floor. Do not adjust the height of the projector except the use of the adjuster. Avoid using as the unit tilts upward or downward. These installation may cause malfunction.

No blocking the ventilation holes



Avoid using something to cover over the ventilation holes; otherwise, the internal heat may build up.

Specifications

Optical characteristics

Projection system	3 LCD panels, 1 lens, projection system
LCD panel	0.9-inch TFT LCD panel with micro-lens array, 2,359,296 pixels (786,432 pixels × 3)
Lens	1.3 times zoom lens f 37.3 to 48.5 mm/F 1.7 to 2.0
Lamp	120 W UHP
Projection picture size	Range: 40 to 200 inches (diagonal measure)
Light output	ANSI lumen ¹⁾ 1000 lm
Throwing distance	40-inch: 1590 to 2040 mm (62 ⁵ / ₈ to 80 ³ / ₈ inches) 60-inch: 2440 to 3100 mm (96 ¹ / ₈ to 122 ¹ / ₈ inches) 80-inch: 3280 to 4160 mm (129 ¹ / ₄ to 163 ⁷ / ₈ inches) 100-inch: 4120 to 5220 mm (162 ¹ / ₄ to 205 ⁵ / ₈ inches) 120-inch: 4970 to 6280 mm (195 ³ / ₄ to 247 ¹ / ₄ inches) 150-inch: 6230 to 7870 mm (245 ³ / ₈ to 309 ⁷ / ₈ inches) 200-inch: 8340 to 10520 mm (328 ³ / ₈ to 414 ¹ / ₄ inches)

Electrical characteristics

Color system	NTSC _{3.58} /PAL/SECAM/NTSC _{4.43} /PAL-M system, switched automatically/manually
Resolution	750 horizontal TV lines (Video input) 1024 × 768 dots (RGB input)
Acceptable computer signals	fH: 15 to 91 kHz fV: 50 to 85 Hz
Speaker	Stereo speakers system, 36 mm (1 ⁷ / ₁₆ inches) diameter, max. 1.0 W × 2

Input/Output

Video/audio input	VIDEO: phono type Composite video: 1 V _{p-p} ±2 dB sync negative (75 ohms terminated) S VIDEO: Y/C mini DIN 4-pin type (male) Y (luminance): 1 V _{p-p} ±2 dB sync negative (75 ohms terminated) C (chrominance): burst 0.286 V _{p-p} ±2 dB (NTSC) (75 ohms terminated), burst 0.3 V _{p-p} ±2 dB (PAL) (75 ohms terminated) AUDIO: Phono type × 2 500 mV _{rms} , impedance more than 47 kilohms
INPUT A	INPUT A: HD D-sub15-pin (female) Analog RGB/component: R/R-Y: 0.7 V _{p-p} ±2 dB (75 ohms terminated) G: 0.7 V _{p-p} ±2 dB (75 ohms terminated) G with sync/Y: 1 V _{p-p} ±2 dB sync negative (75 ohms terminated) B/B-Y: 0.7 V _{p-p} ±2 dB (75 ohms terminated) SYNC/HD: Composite sync input: 1-5 V _{p-p} high impedance, positive/negative Horizontal sync input: 1-5 V _{p-p} high impedance, positive/negative VD: Vertical sync input: 1-5 V _{p-p} high impedance, positive/negative MOUSE (output): 13-pin (female) (For details, see "Pin assignment" on page 30 (GB).) AUDIO: Stereo minijack 500 mV _{rms} , impedance more than 47 kilohms

(Continued)

1) ANSI lumen is a measuring method of American National Standard IT 7.228.

Specifications

AUDIO OUT (variable out): stereo minijack
Max. 500 mVrms, impedance
less than 5 kilohms
Safety regulations: UL1950, cUL (CSA C22.2
No.950), FCC Class A, IC Class
A, DHHS,
EN60950, EN60825-1, CE, C-Tick

Laser beam

Laser type Class 2
Wavelength 645 nm
Output 1 mW

General

Dimensions 108 × 223 × 337 mm (4 ³/₈ × 8 ⁷/₈ ×
13 ³/₈ inches) (w/h/d)
Mass Approx. 4 kg (8 lb 13 oz)
Power requirements
AC 100 to 240 V, 2A/0.9A,
50/60 Hz
Power consumption
Max. 200 W (Standby mode: 2 W)
Heat dissipation 648.37 BTU
Operating temperature
0°C to 40°C (32°F to 104°F)
Operating humidity
35% to 85% (no condensation)
Storage temperature
-20°C to 60°C (-4°F to 140°F)
Storage humidity 10% to 90%
Supplied accessories
Remote Commander RM-PJM600
(1)
Size AA (R6) batteries (2)
HD D-sub 15-pin Cable (1)
Mouse Cable
SIC-S22 (for PS/2) (2 m) (1)
Audio/video cable (1.5 m) (1)
Strap for Remote Commander (1)
AC power cord (1)
Air filter (for replacement) (1)
Operating Instructions (1)
Quick Reference Card (1)
Warranty Card (1)

Design and specifications are subject to change
without notice.

Optional accessories

Projector Lamp LMP-P120¹⁾ (for replacement)
Carrying Case VLC-SC50¹⁾
Signal Selector IFU-SC50
Video Signal Cable SMF-401 (HD D-sub 15-pin
(male) ↔ HD D-sub 15-pin (male))
Signal Cable
SMF-402 (HD D-sub 15-pin (male) ↔ 3 × phono
type (male))
Mouse Cable
SIC-S20 (for Macintosh) (2 m)
SIC-S21 (for Serial) (2 m)
SIC-S22 (for PS/2) (2 m)
Signal Adapter
ADP-10 (HD D-sub 15-pin ↔ D-sub 9-pin (for
SIC cable))
ADP-20 (Macintosh ↔ HD D-sub 15-pin)
SIC cable
SIC-20A/20C/21/22
Screens
80-inch Portable VPS-80C
100-inch Flat Screen VPS-100FH
120-inch Flat Screen VPS-120FH

*Some of the items may not be available in some areas. For
details, please consult your nearest Sony office.*

Pin assignment

INPUT A connector (HD D-sub 15-pin, female)

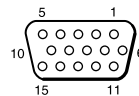

1	R/R-Y	9	N.C.
2	G/Y	10	GND
3	B/B-Y	11	GND
4	GND	12	N.C.
5	GND	13	HD/C.Sync
6	GND (R)	14	VD
7	GND (G)	15	N.C.
8	GND (B)		

1) LMP-P120 and VLC-SC50 may not be available in some areas. For details, please consult your nearest Sony office.

MOUSE connector (13-pin, female)



1	RTS	8	R
2	GND	9	98/AT/TXD
3	XA	10	+5V/DTR
4	XB	11	CLOCK
5	YA	12	DATA
6	YB	13	RXD
7	L/PS		

Mouse cable pin assignment

SIC-S22

13-pin

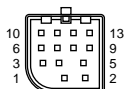

1	RTS	8	R
2	GND	9	98/AT/TXD
3	XA	10	+5V/DTR
4	XB	11	CLOCK
5	YA	12	DATA
6	YB	13	RXD
7	L/PS		

mini DIN 6-pin

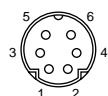

1	DATA
2	NC
3	GND
4	+5V
5	CLOCK
6	NC

Dimensions

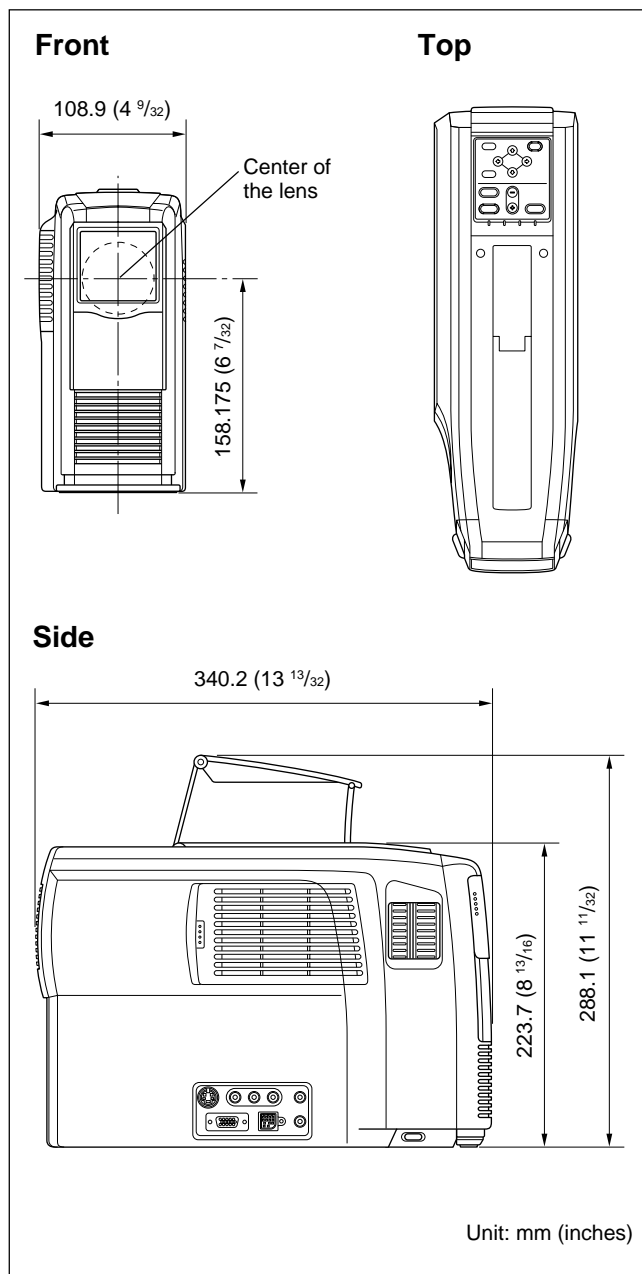

Index

A

- Adjuster 9 (GB)
- Adjusting
 - memory of the settings 19 (GB)
 - the picture 19 (GB), 20 (GB)
 - the picture size/shift 21 (GB)
- Air filter 25 (GB)
- ASPECT 21 (GB)

B

- Battery
 - installation 13 (GB)
 - notes 13 (GB)
- BRIGHT 20 (GB)

C

- Carrying handle 8 (GB)
- COLOR 20 (GB)
- COLOR SYS (System) 20 (GB)
- COLOR TEMP 20 (GB)
- Connections
 - component equipment 16 (GB)
 - computer 14 (GB)
 - VCR 16 (GB)
- CONTRAST 20 (GB)
- Cut off
 - the picture 17 (GB)
 - the sound 17 (GB)

D, E, F

- Dimensions 31 (GB)
- D. (Dynamic) PICTURE 20 (GB)
- DOT PHASE 21 (GB)

G

- GAMMA MODE 20 (GB)

H

- HUE 20 (GB)

I, J, K

- INPUT-A 23 (GB)
- INPUT A connector 11 (GB)
 - pin assignment 30 (GB)
- INPUT SETTING menu 21 (GB)
- Installation examples 14 (GB)
 - notes 28 (GB)
 - unsuitable places 28 (GB)

L

- Lamp replacement 24 (GB)
- LANGUAGE 23 (GB)
- Laser pointer function 12 (GB)
- Location and function of controls
 - connector panel 11 (GB)
 - control panel 10 (GB)
 - front/left side 8 (GB)
 - rear/right side/bottom 8 (GB)
 - Remote Commander 12 (GB)

M, N

- Menu
 - clearing the menu display 19 (GB)
 - INPUT SETTING menu 21 (GB)
 - PICTURE CTRL menu 19 (GB)
 - SET SETTING menu 23 (GB)
 - using the menu 19 (GB)
- Message
 - caution 27 (GB)
 - warning 27 (GB)
- Mouse cable
 - connection 15 (GB)
 - pin assignment 31 (GB)
- Mouse connector 11 (GB)
 - pin assignment 31 (GB)

O

- Optional accessories 30 (GB)

P, Q

- PICTURE CTRL menu 19 (GB)
- Pin assignment 30 (GB), 31 (GB)
- Power
 - turn off 18 (GB)
 - turn on 17 (GB)
- POWER SAVING 10 (GB), 23 (GB)
- Precautions 6 (GB)

R

- Remote Commander
 - battery installation 13 (GB)
 - laser pointer function 12 (GB)
 - location and function of controls 12 (GB)
- Remote control detector
 - front 8 (GB)
 - rear 8 (GB)
 - setting 23 (GB)
- Reset
 - resettable items 19 (GB)
 - resetting the item 19 (GB)

S

- SCAN CONV (Scan converter) 21 (GB)
- Screen size 14 (GB), 22 (GB), 29 (GB)
- SET SETTING menu 23 (GB)
- SHARP 20 (GB)
- SHIFT 21 (GB)
- SIRCS RECEIVER 8 (GB), 23 (GB)
- SIZE 21 (GB)
- SPEAKER 23 (GB)
- Specifications 29 (GB)
- STATUS (on-screen display) 23 (GB)
- Supplied accessories 30 (GB)

T, U

- Troubleshooting 26 (GB)

V, W, X, Y, Z

- Ventilation holes
 - exhaust 8 (GB)
 - intake 9 (GB)