

> LS920WU/LS921WU

Projector User Guide

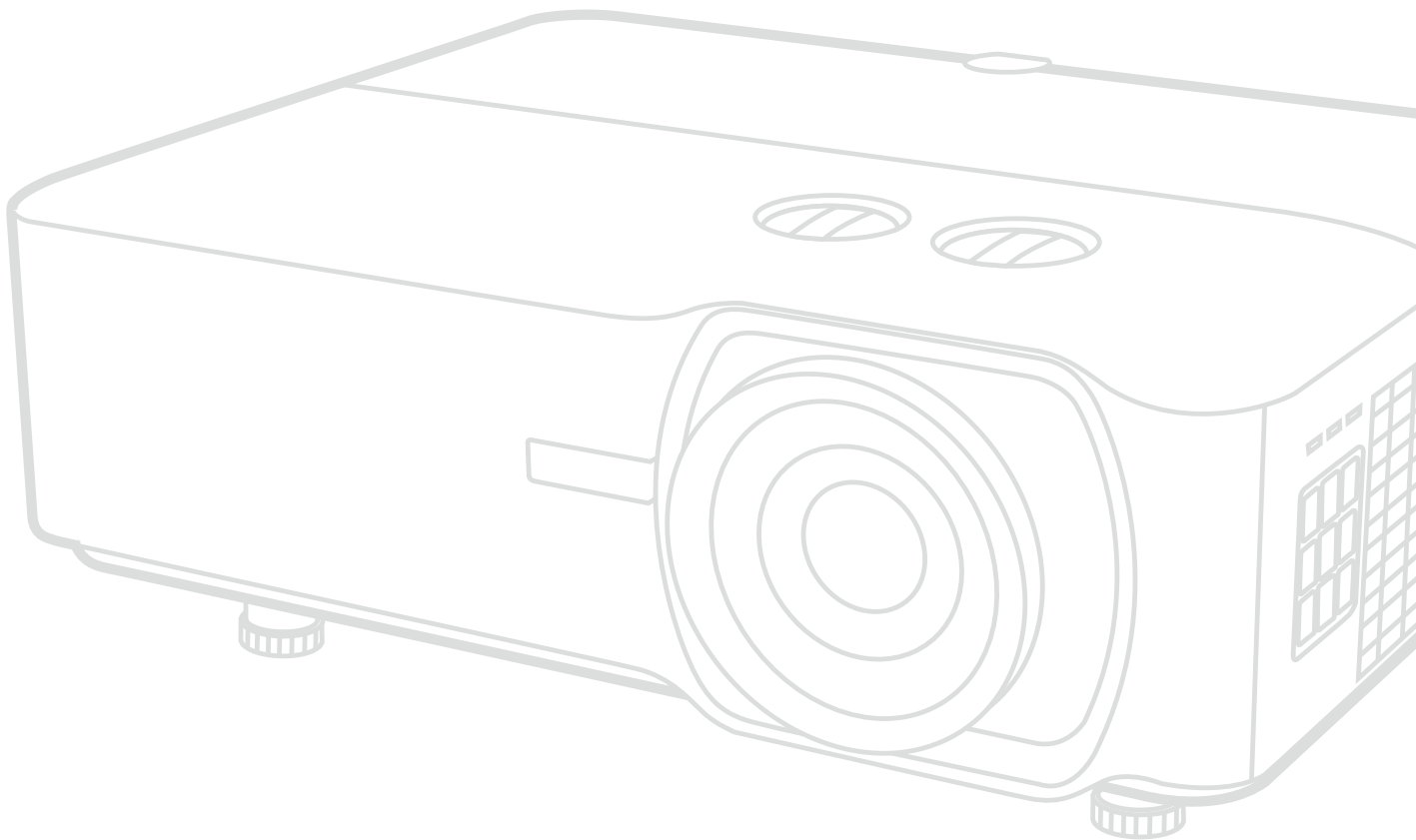

IMPORTANT: Please read this User Guide to obtain important information on installing and using your product in a safe manner, as well as registering your product for future service. Warranty information contained in this User Guide will describe your limited coverage from ViewSonic Corporation, which is also found on our web site at <http://www.viewsonic.com> in English, or in specific languages using the Regional selection box in the upper right corner of our website. "Antes de operar su equipo lea cuidadosamente las instrucciones en este manual"

Thank you for choosing ViewSonic®

As a world-leading provider of visual solutions, ViewSonic® is dedicated to exceeding the world's expectations for technological evolution, innovation, and simplicity. At ViewSonic®, we believe that our products have the potential to make a positive impact in the world, and we are confident that the ViewSonic® product you have chosen will serve you well.

Once again, thank you for choosing ViewSonic®!

> Safety Precautions

Please read the following **Safety Precautions** before you start using the projector.

- Keep this user guide in a safe place for later reference.
- Read all warnings and follow all instructions.
- Allow at least 20" (50 cm) clearance around the projector to ensure proper ventilation.
- Place the projector in a well-ventilated area. Do not place anything on the projector that prevents heat dissipation.
- Do not place the projector on an uneven or unstable surface. The projector may fall over, causing personal injury or projector malfunction.
- Do not use if the projector is tilted at an angle of more than 10° degrees left or right, nor at an angle of more than 15° degrees forwards or backwards.
- Do not look straight at the projector lens during operation. The intense light beam may damage your eyes.
- Do not block the projection lens with any objects when the projector is under operation as this could cause objects to become heated and deformed or even cause a fire.
- Do not attempt to disassemble the projector. There are dangerous high voltages inside which may cause death if you should come into contact with live parts.
- When moving the projector, be careful not to drop or bump the projector on anything.
- Do not place any heavy objects on the projector or connection cables.
- Do not stand the projector on end vertically. Doing so may cause the projector to fall over, causing personal injury or projector malfunction.
- Avoid exposing the projector to direct sunlight or other sources of sustained heat. Do not install near any heat sources such as radiators, heat registers, stoves, or other devices (including amplifiers) that may increase the temperature of the projector to dangerous levels.
- Do not place liquids near or on the projector. Liquids spilled into the projector may cause it to fail. If the projector does become wet, disconnect it from the power supply and call your local service center to have the projector serviced.
- When the projector is under operation, you may sense some heated air and odor from its ventilation grill. It is a normal operation and not a defect.

- Do not attempt to circumvent the safety provisions of the polarized or grounding-type plug. A polarized plug has two blades with one wider than the other. A grounding-type plug has two blades and a third grounding prong. The wide and third blade are provided for your safety. If the plug does not fit into your outlet, obtain an adapter and do not attempt to force the plug into the outlet.
- When connecting to a power outlet, DO NOT remove the grounding prong. Please ensure grounding prongs are NEVER REMOVED.
- Protect the power cord from being treaded upon or pinched, particularly at the plug, and at the point where it emerges from the projector.
- In some countries, the voltage is NOT stable. This projector is designed to operate safely within a voltage between 100 to 240 volts AC, but could fail if power cuts or surges of ± 10 volts occur. In areas where voltage may fluctuate or cut out, it is recommended that you connect your projector through a power stabilizer, surge protector, or uninterruptable power supply (UPS).
- If smoke, an abnormal noise, or a strange odor is present, immediately switch the projector off and call your dealer or ViewSonic®. It is dangerous to continue using the projector.
- Use only attachments/accessories specified by the manufacturer.
- Disconnect the power cord from the AC outlet if the projector is not being used for a long period of time.
- Refer all servicing to qualified service personnel.



CAUTION: Possibly hazardous optical radiation is emitted from this product. As with any bright light source, do not stare into the beam, RG2 IEC 62471-5:2015

> Contents

| | |
|--|-----------|
| Introduction | 8 |
| Product Overview | 9 |
| Projector | 9 |
| Controls and Functions..... | 9 |
| Connection Ports..... | 10 |
| Remote Control..... | 11 |
| Controls and Functions..... | 11 |
| Remote Control Effective Range..... | 12 |
| Replacing the Remote Control Batteries..... | 12 |
| Choosing a Location | 13 |
| Initial Setup..... | 13 |
| Projection Dimensions | 14 |
| LS920WU | 15 |
| 16:10 Image on a 16:10 Screen | 15 |
| 16:10 Image on a 4:3 Screen..... | 15 |
| LS921WU | 16 |
| 16:10 Image on a 16:10 Screen | 16 |
| 16:10 Image on a 4:3 Screen..... | 16 |
| Mounting the Projector | 17 |
| Preventing Unauthorized Use | 18 |
| Using the Security Slot | 18 |
| Using the Password Function | 19 |
| Setting a Password..... | 19 |
| Changing the Password | 20 |
| Disabling the Password Function..... | 20 |
| Forgetting the Password | 21 |
| Password Recall Procedure | 21 |
| Locking the Control Keys | 22 |
| Connecting to Power | 23 |

| | |
|---|-----------|
| Making Connections | 23 |
| Connecting to Video Sources..... | 24 |
| HDMI Connection | 24 |
| S-Video Connection | 24 |
| Composite Video Connection..... | 24 |
| Connecting to Computer Sources..... | 24 |
| VGA Connection | 24 |
| VGA Out Connection | 24 |
| Connecting to Audio | 24 |
| Connecting to HDBaseT Device | 24 |
| Turning the Projector On/Off | 26 |
| Starting Up the Projector | 26 |
| First Time Activation | 26 |
| Operation..... | 26 |
| Shutting Down the Projector..... | 27 |
| Selecting an Input Source | 28 |
| Adjusting the Projected Image | 29 |
| Adjusting the Projector's Height and Projection Angle..... | 29 |
| Auto-Adjusting the Image | 29 |
| Fine-Tuning the Image Size and Clarity | 29 |
| Correcting Keystone | 30 |
| Controllability of the Projected Image | 31 |
| Hiding the Image | 31 |
| Controlling the Projector through a LAN Environment | 32 |
| Configuring the LAN Control Settings..... | 32 |
| General On-Screen Display (OSD) Menu Operation | 34 |
| Menu Functions | 34 |
| On-Screen Display (OSD) Menu Tree..... | 35 |
| DISPLAY Menu | 42 |
| IMAGE Menu | 45 |
| POWER MANAGEMENT Menu | 49 |
| BASIC Menu | 52 |
| ADVANCED Menu | 55 |
| SYSTEM Menu..... | 59 |
| INFORMATION Menu | 61 |

| | |
|-----------------------------------|-----------|
| Specifications..... | 62 |
| Appendix..... | 62 |
| Projector Dimensions..... | 63 |
| Timing Chart | 63 |
| Analog RGB..... | 63 |
| HDMI (PC)..... | 65 |
| HDMI (Video)..... | 66 |
| Video/S-Video | 67 |
| Component video..... | 67 |
| HDBaseT | 67 |
| Troubleshooting | 68 |
| Common Problems..... | 68 |
| LED Indicators..... | 69 |
| Maintenance..... | 70 |
| General Precautions | 70 |
| Cleaning the Lens | 70 |
| Cleaning the Case | 70 |
| Storing the Projector | 70 |
| Disclaimer..... | 70 |
| Light Source Information..... | 71 |
| Light Source Hour | 71 |
| Extending Light Source Life | 71 |

> Introduction

Package Contents

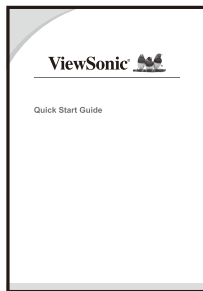
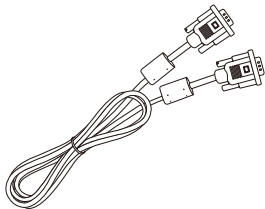
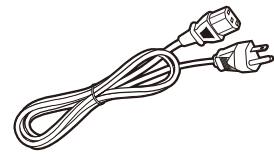
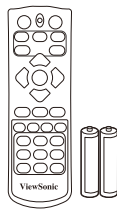
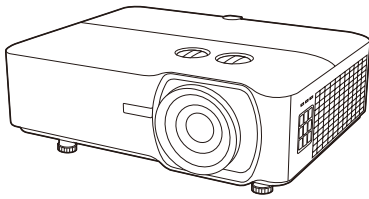

NOTE: The power cord and video cables included in your package may vary depending on your country. Please contact your local reseller for more information.

Product Overview

Projector

Controls and Functions

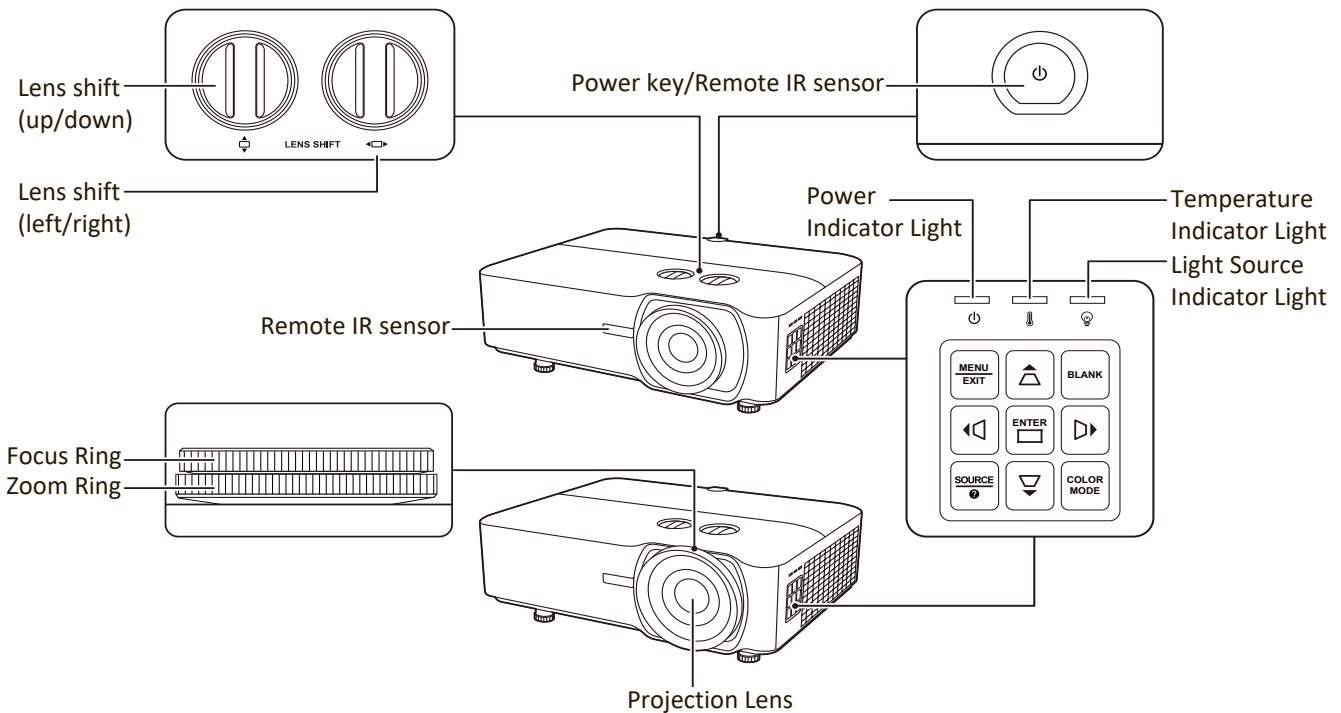

| Key | Description |
|-----------------------|--|
| [] Power | Toggles the projector between standby mode and Power On. |
| [] Keystone Keys | Manually corrects distorted images resulting from an angled projection. |
| [] Left/Right/Up/Down | Selects the desired menu items and makes adjustments when the On-Screen Display (OSD) Menu is activated. |
| Menu/Exit | Turns on or off the On-Screen Display (OSD) Menu. |
| Source | Displays the input source selection bar. |
| (Help) | Displays the HELP menu with a long press for 3 seconds. |
| Blank | Hides the screen picture. |
| Enter | Enacts the selected On-Screen Display (OSD) Menu item when the OSD Menu is activated. |
| [] Corner Adjustment | Displays the Corner Adj. menu when the OSD menu is not activated. |
| Color Mode | Displays the color mode selection bar. |

Connection Ports

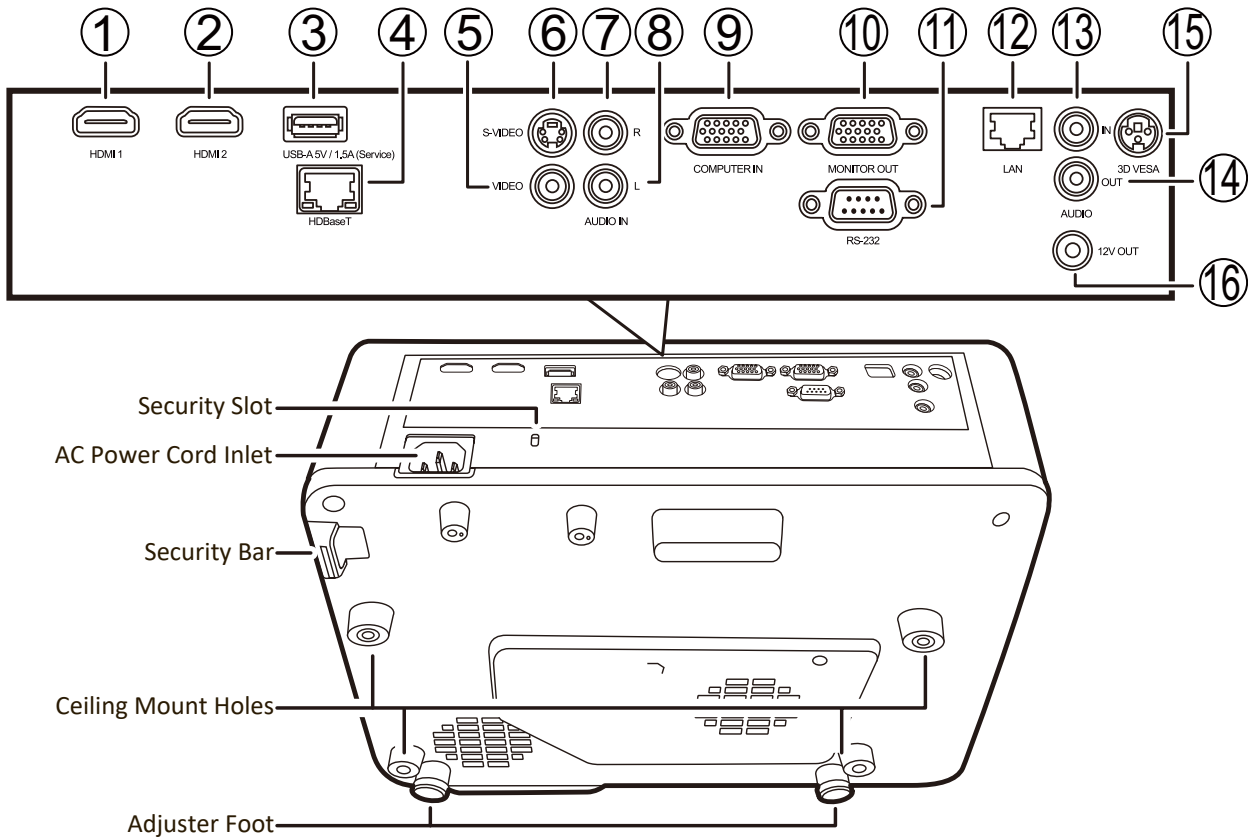

| Port | Description |
|-------------------------------|---|
| [1] HDMI 1 | HDMI port. |
| [2] HDMI 2 | HDMI port. |
| [3] USB 5V/1.5A OUT (Service) | USB Type A port for power supply and service. |
| [4] HDBase T | HDBaseT port. |
| [5] VIDEO | Composite video port. |
| [6] S-VIDEO | S-Video port. |
| [7] AUDIO IN (R) | Audio signal (right) input socket. |
| [8] AUDIO IN (L) | Audio signal (left) input socket. |
| [9] COMPUTER IN | RGB (PC) signal input socket. |
| [10] MONITOR OUT | RGB (PC) signal output socket. |
| [11] RS-232 | RS-232 control port. |
| [12] RJ-45 | LAN port. |
| [13] AUDIO IN | Audio signal input socket. |
| [14] AUDIO OUT | Audio signal output socket. |
| [15] 3D VESA | 3D VESA port. |
| [16] 12V OUT | 12V DC output terminal. |

Remote Control

Controls and Functions

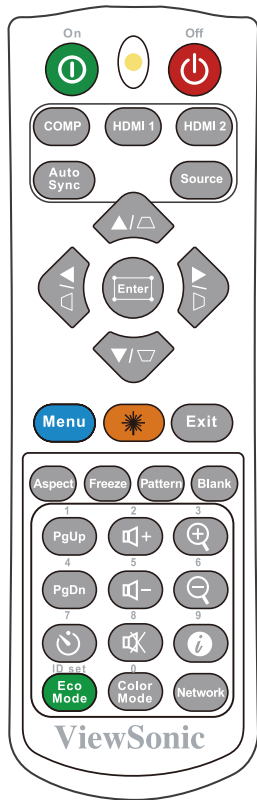

| Button | Description |
|----------------------------|--|
| ⏻ On/⏻ Off | Toggles between standby mode and Power On. |
| COMP | Selects the source from the COMPUTER IN port for display. |
| HDMI 1 | Selects the source from the HDMI 1 port for display. |
| HDMI 2 | Selects the source from the HDMI 2 port for display. |
| Auto Sync | Automatically determines the best picture timings for the displayed image. |
| Source | Displays the source selection bar. |
| [⏏/⏏/⏏/⏏] Keystone Keys | Manually corrects distorted images resulting from an angled projection. |
| Enter | Enacts the selected OSD Menu item. |
| ⏏ (Corner adjustment) | Displays the Corner Adj. menu when the OSD menu is not activated. |

| Button | Description |
|-------------------------------------|--|
| ◀ Left/ ▶ Right ▲ Up/ ▼ Down | Selects the desired menu items and makes adjustments. |
| Menu | Turns on/off the On-Screen Display (OSD) Menu or goes back to previous OSD Menu. |
| ★ (Laser) | Emits visible laser pointer light for presentation purposes. |
| Exit | Exits and saves menu settings. |
| Aspect | Displays the aspect ratio selection bar. |
| Freeze | Freezes the projected image. |
| Pattern | Displays embedded test pattern. |
| Blank | Hides the screen picture. |
| PgUp (Page Up)/ PgDn (Page Down) | Operates your display software program (on a connected PC) which responds to page up/down commands (like Microsoft PowerPoint). NOTE: Only available when a PC input signal is selected. |
| ⌚ (Presentation Timer) | Displays the Presentation Timer menu. |
| Eco Mode | Selects the Eco mode. |
| 🔊+ (Volume Up) | Increases the volume level. |
| 🔊- (Volume Down) | Decreases the volume level. |
| 🔇 (Mute) | Toggles audio between on and off. |
| Color Mode | Displays the color mode selection bar. |
| 🔍+ | Magnifies the projected picture size. |
| 🔍- | Reduces the projected picture size. |
| ℹ️ (INFORMATION) | Displays the INFORMATION menu. |
| Network | Displays the LAN Control Settings menu. |

Remote Control Effective Range

To ensure proper function of the remote control follow the steps below:

1. The remote control must be held at an angle within 30° perpendicular to the projector's IR remote control sensor(s).
2. The distance between the remote control and the sensor(s) should not exceed 8 m (26 ft.)

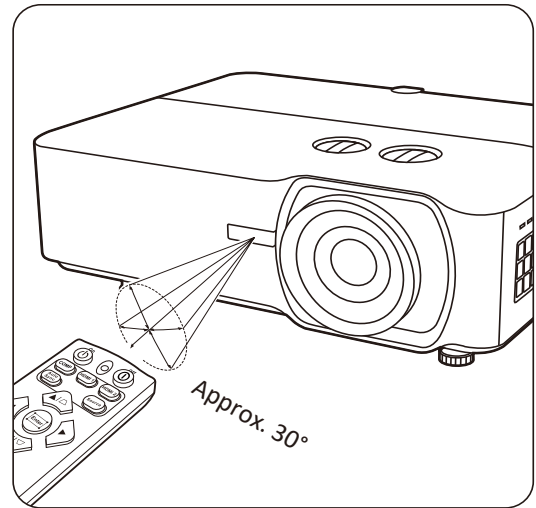

NOTE: Refer to the illustration for the location of the infrared (IR) remote control sensor(s).

Replacing the Remote Control Batteries

1. Remove the battery cover from the rear of the remote control by pressing the finger grip and sliding it down.
2. Remove any existing batteries (if necessary) and install two AAA batteries.

NOTE: Observe the battery's polarities as indicated.

3. Replace the battery cover by aligning it with the base and pushing it back into position.

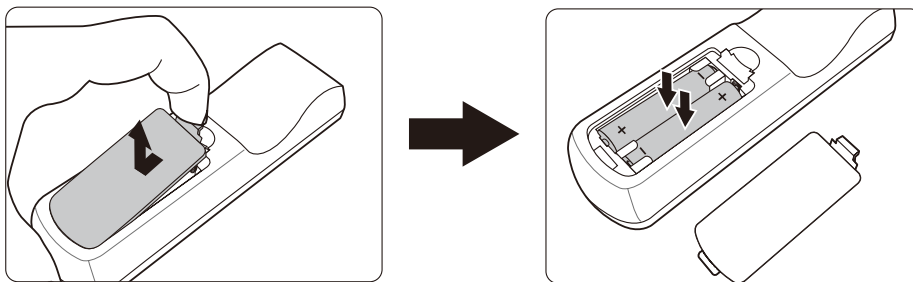

NOTE:

- Avoid leaving the remote control and batteries in excessive heat or a humid environment.
- Replace only with the same or equivalent type recommended by the battery manufacturer.
- Dispose of the used batteries according to the manufacturer's instructions and local environment regulations for your region.
- If the batteries are drained or if you will not be using the remote control for an extended period of time, remove the batteries to avoid damage to the remote control.

> Initial Setup

This section provides detailed instructions for setting up your projector.

Choosing a Location

Personal preference and room layout will decide the installation location. Consider the following:

- Size and Position of your screen.
- Location of a suitable power outlet.
- Location and Distance between the projector and other equipment.

The projector is designed to be installed in one of the following locations:

1. Front

The projector is placed near the floor in front of the screen.

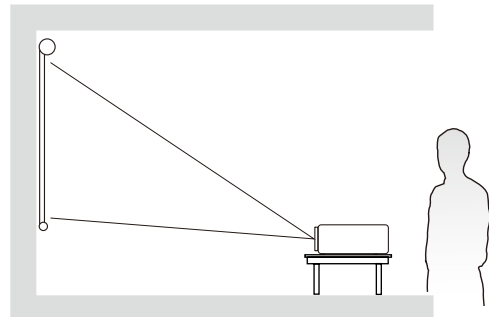

2. Front Ceiling

The projector is suspended upside-down from the ceiling in front of the screen.

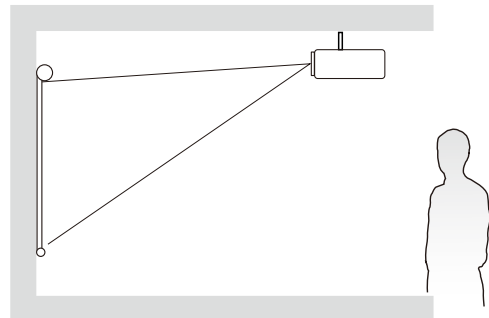

3. Rear Ceiling

The projector is suspended upside-down from the ceiling behind the screen.

NOTE: A special rear projection screen is required.

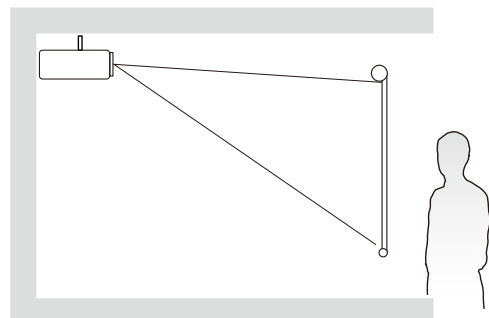

4. Rear

The projector is placed near the floor behind the screen.

NOTE: A special rear projection screen is required.

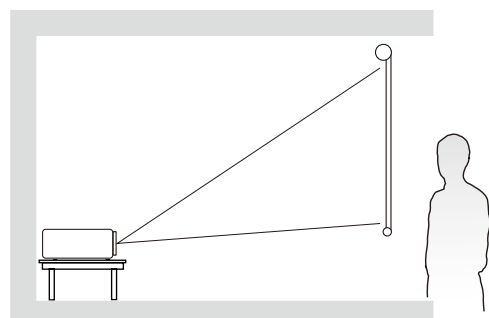

Projection Dimensions

NOTE: See “Specifications” on page 62 for the native display resolution of this projector.

- **16:10 Image on a 16:10 Screen**

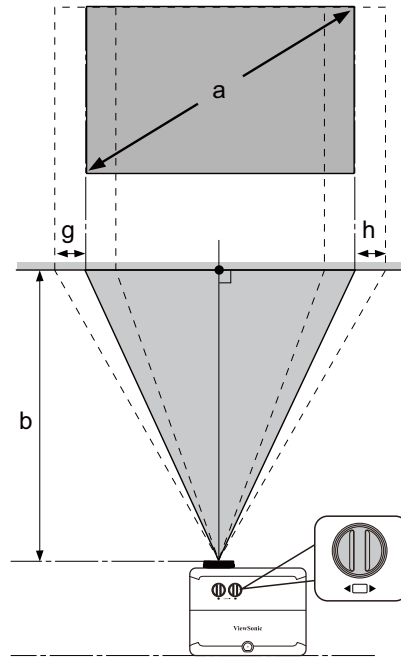
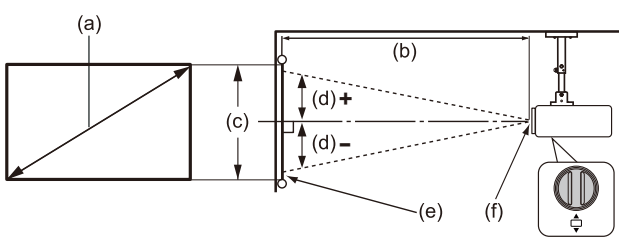
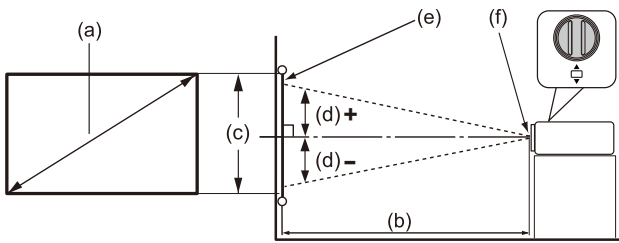

- **16:10 Image on a 4:3 Screen**

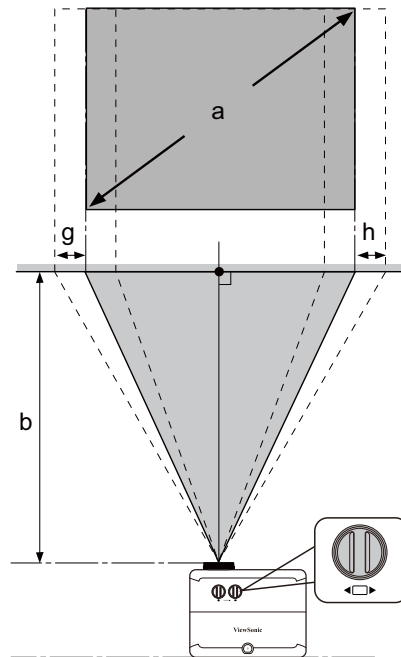
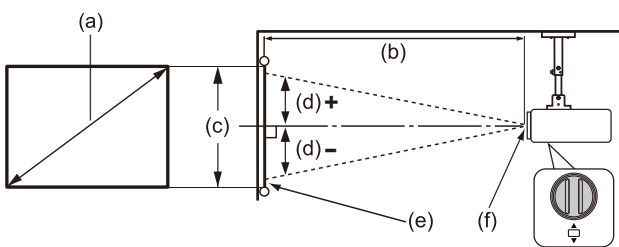
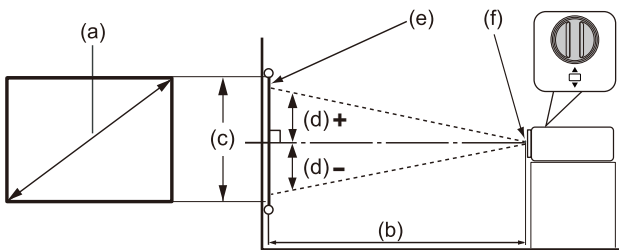

NOTE: (e) = Screen / (f) = Center of Lens

LS920WU

16:10 Image on a 16:10 Screen

| (a) Screen Size | | (b) Projection Distance | | | | (c) Image Height | | (d) Vertical Offset | | | |
|-----------------|------|-------------------------|------|---------|-------|------------------|------|---------------------|-------|---------|------|
| | | minimum | | maximum | | | | minimum | | maximum | |
| in. | mm | in. | mm | in. | mm | in. | mm | in. | mm | in. | mm |
| 30 | 762 | 34 | 876 | 55 | 1401 | 16 | 404 | -8 | -202 | 8 | 202 |
| 40 | 1016 | 46 | 1168 | 74 | 1869 | 21 | 538 | -11 | -269 | 11 | 269 |
| 50 | 1270 | 57 | 1460 | 92 | 2336 | 26 | 673 | -13 | -337 | 13 | 337 |
| 60 | 1524 | 69 | 1752 | 110 | 2803 | 32 | 808 | -16 | -404 | 16 | 404 |
| 70 | 1778 | 80 | 2044 | 129 | 3270 | 37 | 942 | -19 | -471 | 19 | 471 |
| 80 | 2032 | 92 | 2336 | 147 | 3737 | 42 | 1077 | -21 | -538 | 21 | 538 |
| 90 | 2286 | 103 | 2628 | 166 | 4204 | 48 | 1212 | -24 | -606 | 24 | 606 |
| 100 | 2540 | 115 | 2920 | 184 | 4671 | 53 | 1346 | -26 | -673 | 26 | 673 |
| 120 | 3048 | 138 | 3503 | 221 | 5606 | 64 | 1615 | -32 | -808 | 32 | 808 |
| 150 | 3810 | 172 | 4379 | 276 | 7007 | 79 | 2019 | -40 | -1010 | 40 | 1010 |
| 200 | 5080 | 230 | 5839 | 368 | 9343 | 106 | 2692 | -53 | -1346 | 53 | 1346 |
| 250 | 6350 | 287 | 7299 | 460 | 11678 | 132 | 3365 | -66 | -1683 | 66 | 1683 |
| 300 | 7620 | 345 | 8759 | 552 | 14014 | 159 | 4039 | -79 | -2019 | 79 | 2019 |

16:10 Image on a 4:3 Screen

| (a) Screen Size | | (b) Projection Distance | | | | (c) Image Height | | (d) Vertical Offset | | | |
|-----------------|------|-------------------------|------|---------|------|------------------|------|---------------------|-------|---------|------|
| | | minimum | | maximum | | | | minimum | | maximum | |
| in. | mm | in. | mm | in. | mm | in. | mm | in. | mm | in. | mm |
| 30 | 762 | 65 | 1653 | 104 | 2644 | 30 | 762 | -15 | -381 | 15 | 381 |
| 40 | 1016 | 76 | 1928 | 121 | 3085 | 35 | 889 | -18 | -445 | 18 | 445 |
| 50 | 1270 | 87 | 2203 | 139 | 3525 | 40 | 1016 | -20 | -508 | 20 | 508 |
| 60 | 1524 | 98 | 2479 | 156 | 3966 | 45 | 1143 | -23 | -572 | 23 | 572 |
| 70 | 1778 | 108 | 2754 | 173 | 4407 | 50 | 1270 | -25 | -635 | 25 | 635 |
| 80 | 2032 | 119 | 3030 | 191 | 4848 | 55 | 1397 | -28 | -699 | 28 | 699 |
| 90 | 2286 | 130 | 3305 | 208 | 5288 | 60 | 1524 | -30 | -762 | 30 | 762 |
| 100 | 2540 | 141 | 3581 | 226 | 5729 | 65 | 1651 | -33 | -826 | 33 | 826 |
| 120 | 3048 | 152 | 3856 | 243 | 6170 | 70 | 1778 | -35 | -889 | 35 | 889 |
| 150 | 3810 | 163 | 4131 | 260 | 6610 | 75 | 1905 | -38 | -953 | 38 | 953 |
| 200 | 5080 | 173 | 4407 | 278 | 7051 | 80 | 2032 | -40 | -1016 | 40 | 1016 |
| 250 | 6350 | 184 | 4682 | 295 | 7492 | 85 | 2159 | -43 | -1080 | 43 | 1080 |
| 300 | 7620 | 195 | 4958 | 312 | 7932 | 90 | 2286 | -45 | -1143 | 45 | 1143 |

NOTE: There is a 3% tolerance among these numbers due to optical component variations. It is recommended to physically test the projection size and distance before permanently installing the projector.

LS921WU

16:10 Image on a 16:10 Screen

| (a) Screen Size | | (b) Projection Distance | | | | (c) Image Height | | (d) Vertical Offset | | | |
|-----------------|------|-------------------------|------|---------|------|------------------|------|---------------------|-------|---------|------|
| | | minimum | | maximum | | | | minimum | | maximum | |
| in. | mm | in. | mm | in. | mm | in. | mm | in. | mm | in. | mm |
| 30 | 762 | 20 | 521 | 23 | 573 | 16 | 404 | -8 | -202 | 8 | 202 |
| 40 | 1016 | 27 | 694 | 30 | 764 | 21 | 538 | -11 | -269 | 11 | 269 |
| 50 | 1270 | 34 | 868 | 38 | 955 | 26 | 673 | -13 | -337 | 13 | 337 |
| 60 | 1524 | 41 | 1041 | 45 | 1146 | 32 | 808 | -16 | -404 | 16 | 404 |
| 70 | 1778 | 48 | 1215 | 53 | 1336 | 37 | 942 | -19 | -471 | 19 | 471 |
| 80 | 2032 | 55 | 1389 | 60 | 1527 | 42 | 1077 | -21 | -538 | 21 | 538 |
| 90 | 2286 | 61 | 1562 | 68 | 1718 | 48 | 1212 | -24 | -606 | 24 | 606 |
| 100 | 2540 | 68 | 1736 | 75 | 1909 | 53 | 1346 | -26 | -673 | 26 | 673 |
| 120 | 3048 | 82 | 2083 | 90 | 2291 | 64 | 1615 | -32 | -808 | 32 | 808 |
| 150 | 3810 | 102 | 2603 | 113 | 2864 | 79 | 2019 | -40 | -1010 | 40 | 1010 |
| 200 | 5080 | 137 | 3471 | 150 | 3818 | 106 | 2692 | -53 | -1346 | 53 | 1346 |
| 250 | 6350 | 171 | 4339 | 188 | 4773 | 132 | 3365 | -66 | -1683 | 66 | 1683 |
| 300 | 7620 | 205 | 5207 | 225 | 5728 | 159 | 4039 | -79 | -2019 | 79 | 2019 |

16:10 Image on a 4:3 Screen

| (a) Screen Size | | (b) Projection Distance | | | | (c) Image Height | | (d) Vertical Offset | | | |
|-----------------|------|-------------------------|------|---------|------|------------------|------|---------------------|-------|---------|------|
| | | minimum | | maximum | | | | minimum | | maximum | |
| in. | mm | in. | mm | in. | mm | in. | mm | in. | mm | in. | mm |
| 30 | 762 | 39 | 982 | 43 | 1081 | 30 | 762 | -15 | -381 | 15.0 | 381 |
| 40 | 1016 | 45 | 1146 | 50 | 1261 | 35 | 889 | -18 | -445 | 17.5 | 445 |
| 50 | 1270 | 52 | 1310 | 57 | 1441 | 40 | 1016 | -20 | -508 | 20.0 | 508 |
| 60 | 1524 | 58 | 1474 | 64 | 1621 | 45 | 1143 | -23 | -572 | 22.5 | 572 |
| 70 | 1778 | 64 | 1637 | 71 | 1801 | 50 | 1270 | -25 | -635 | 25.0 | 635 |
| 80 | 2032 | 71 | 1801 | 78 | 1981 | 55 | 1397 | -28 | -699 | 27.5 | 699 |
| 90 | 2286 | 77 | 1965 | 85 | 2161 | 60 | 1524 | -30 | -762 | 30.0 | 762 |
| 100 | 2540 | 84 | 2129 | 92 | 2341 | 65 | 1651 | -33 | -826 | 32.5 | 826 |
| 120 | 3048 | 90 | 2292 | 99 | 2522 | 70 | 1778 | -35 | -889 | 35.0 | 889 |
| 150 | 3810 | 97 | 2456 | 106 | 2702 | 75 | 1905 | -38 | -953 | 37.5 | 953 |
| 200 | 5080 | 103 | 2620 | 113 | 2882 | 80 | 2032 | -40 | -1016 | 40.0 | 1016 |
| 250 | 6350 | 110 | 2784 | 121 | 3062 | 85 | 2159 | -43 | -1080 | 42.5 | 1080 |
| 300 | 7620 | 116 | 2947 | 128 | 3242 | 90 | 2286 | -45 | -1143 | 45.0 | 1143 |

NOTE: There is a 3% tolerance among these numbers due to optical component variations. It is recommended to physically test the projection size and distance before permanently installing the projector.

Mounting the Projector

NOTE: If you buy a third-party mount, please use the correct screw size. Screw size can vary depending on the thickness of the mounting plate.

1. To ensure the most secure installation, please use a ViewSonic® wall or ceiling mount.
2. Ensure the screws used to attach a mount to the projector meet the following specifications:
 - Screw type: M4
 - Screw length: 12.8 mm ~ 15.8 mm

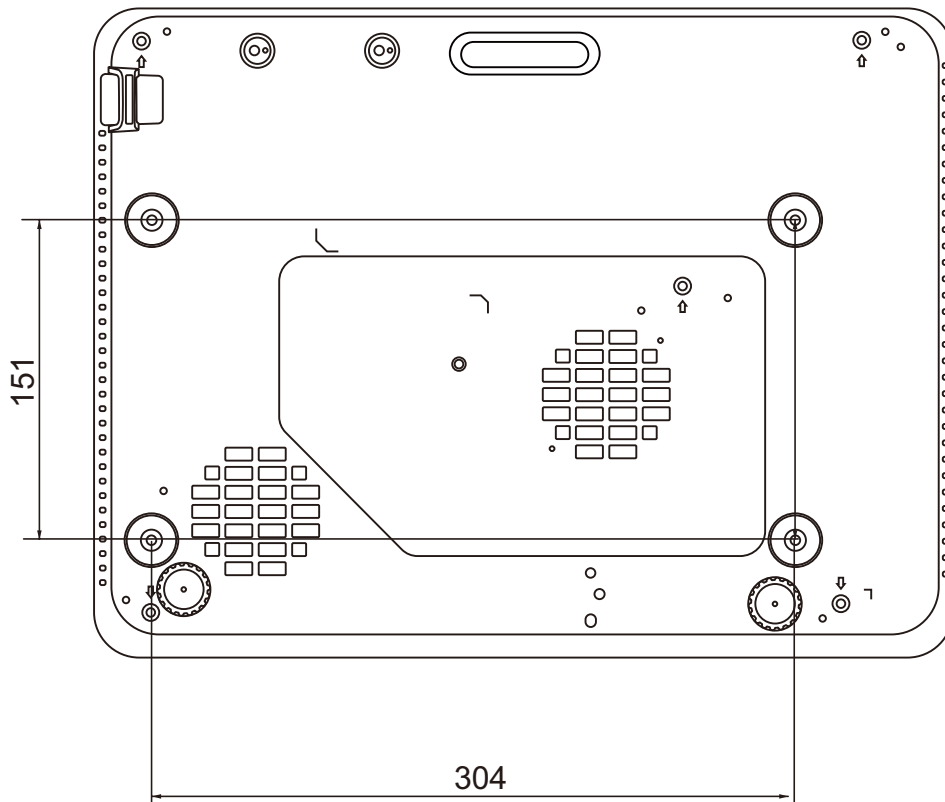

NOTE:

- Avoid installing the projector near a heat source.
- Keep at least a 10 cm gap between the ceiling and the bottom of the projector.

Preventing Unauthorized Use

The projector has several built-in security features to prevent theft, access, or accidental setting changes.

Using the Security Slot

To help prevent the projector from being stolen, use a security slot locking device to secure the projector to a fixed object.

Below is an example of setting up a security slot locking device:

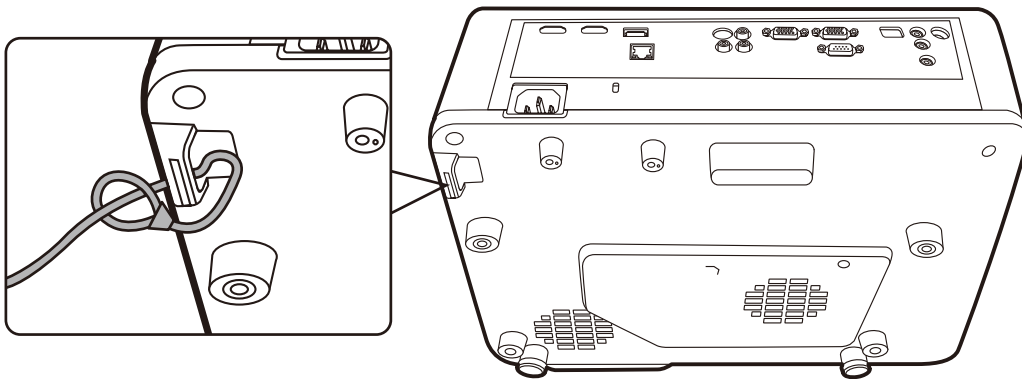

NOTE: The security slot can also be used as a safety anchor if the projector is mounted to the ceiling.

Using the Password Function

To help prevent unauthorized access or use, the projector offers a password security option. The password can be set through the On-Screen Display (OSD) Menu.

NOTE: Make note of your password, and keep it in a safe place.

Setting a Password

1. Press **Menu** to open the OSD Menu and go to: **SYSTEM > Security Settings** and press **Enter**.
2. Highlight **Power On Lock** and select **On** by pressing **◀/▶**.
3. As pictured to the right, the four arrow keys (**▲**, **▶**, **▼**, **◀**) represent 4 digits (1, 2, 3, 4). Press the arrow keys to enter a six digit password.



4. Confirm the new password by re-entering the new password. Once the password is set, the OSD Menu will return to the Security Settings page.
5. Press **Exit** to leave the OSD Menu.

NOTE: Once set, the correct password must be entered every time the projector is started.

Changing the Password

1. Press **Menu** to open the OSD Menu and go to: **SYSTEM > Security Settings > Change Password**.
2. Press **Enter**, the message, 'INPUT CURRENT PASSWORD' will appear.
3. Enter the old password.
 - » If the password is correct, the message, 'INPUT NEW PASSWORD' will appear.
 - » If the password is incorrect, a password error message will appear for 5 seconds followed by the message, 'INPUT CURRENT PASSWORD'. You can try again or press **Exit** to cancel.
4. Enter a new password.
5. Confirm the new password by re-entering the new password.
6. To leave the OSD Menu, press **Exit**.

NOTE: The digits being input will display as asterisks (*).

Disabling the Password Function

1. Press **Menu** to open the OSD Menu and go to: **SYSTEM > Security Settings > Power On Lock**.
2. Press ◀/▶ to select **Off**.
3. The message, "Input Password" will appear. Enter the current password.
 - » If the password is correct, the OSD Menu returns to the Password page with "**Off**" shown in the row of **Power On Lock**.
 - » If the password is incorrect, a password error message will appear for 5 seconds followed by the message, 'INPUT CURRENT PASSWORD'. You can try again or press **Exit** to cancel.

NOTE: Please keep the old password, as you will need it to reactivate the password function.

Forgetting the Password

If the password function is activated, you will be asked to enter the six-digit password every time you turn on the projector. If you enter the wrong password, the password error message, as pictured to the right, will appear for 5 seconds, and the message 'INPUT PASSWORD' follows.

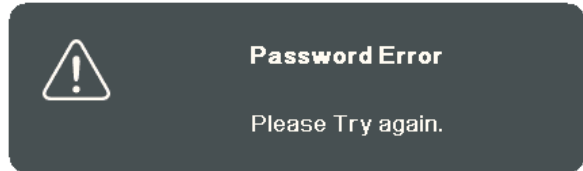

You can retry or if you do not remember, you can use the "Password Recall Procedure".

NOTE: If you enter an incorrect password 5 times in succession, the projector will automatically shut down for a short time.

Password Recall Procedure

1. When the message 'INPUT CURRENT PASSWORD' appears, press and hold **Auto Sync** for 3 seconds. The projector will display a coded number on the screen.
2. Write down the number and turn off your projector.
3. Seek help from the local service center to decode the number. You may be required to provide proof of purchase documentation to verify that you are an authorized user of the projector.

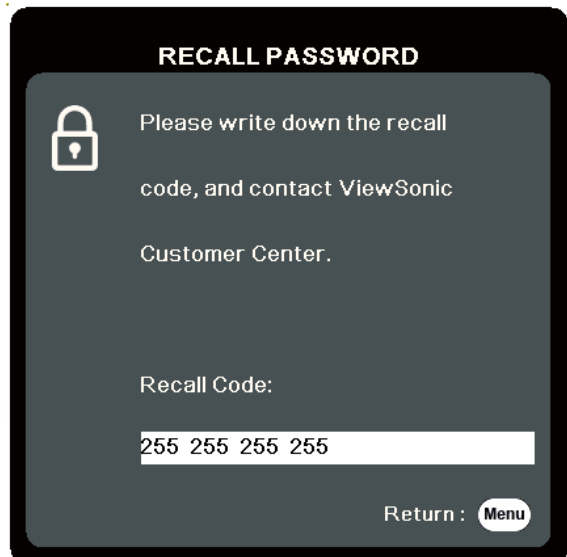

Locking the Control Keys

With the control keys on the projector locked, you can prevent your settings from being changed accidentally (by children, for example).

NOTE: When the **Panel Key Lock** is On, no control keys on the projector will operate except **Power**.

1. Press **Menu** to open the OSD Menu and go to: **SYSTEM > Panel Key Lock**.
2. Press **▲/▼** to select **On**.
3. Select **Yes** and press **Enter** to confirm.
4. To release panel key lock, press and hold **▶** on the projector for 3 seconds.

NOTE: You can also use the remote control to enter the **SYSTEM > Panel Key Lock** menu and select **Off**.

> Making Connections

This section guides you on how to connect the projector with other equipment.

Connecting to Power

1. Connect the power cord to the AC IN jack at the rear of the projector.
2. Plug the power cord into a power outlet.

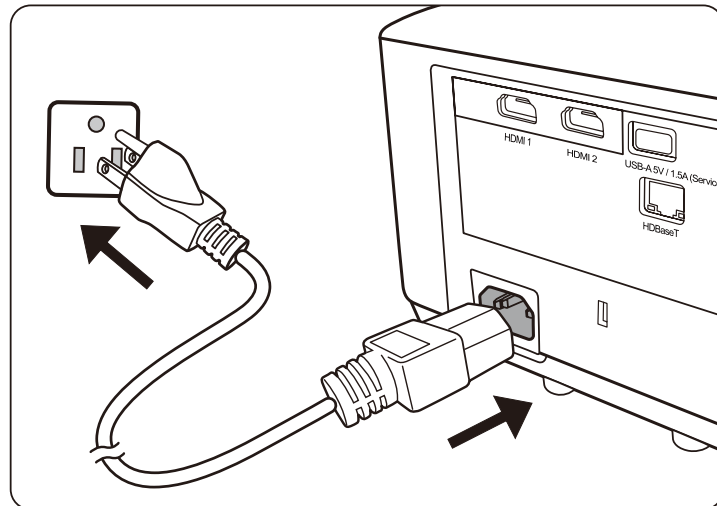

NOTE: When installing the projector, incorporate a readily accessible disconnect device in the fixed wiring, or connect the power plug to an easily accessible outlet near the unit. If a fault should occur during operation of the projector, use the disconnect device to switch off the power supply, or disconnect the power plug.

Connecting to Video Sources

HDMI Connection

Connect one end of an HDMI cable to the HDMI port of your video device. Then connect the other end of the cable to the **HDMI 1** or **HDMI 2** port of your projector.

S-Video Connection

Connect one end of an S-Video cable to the S-Video port of your video device. Then connect the other end of the cable to the **S-VIDEO** port of your projector.

Composite Video Connection

Connect one end of a Video cable to the Video port of your video device. Then connect the other end of the cable to the **VIDEO** port of your projector.

Connecting to Computer Sources

VGA Connection

Connect one end of a VGA cable to the VGA port of your computer. Then connect the other end of the cable to the **COMPUTER IN** port of your projector.

NOTE: Some notebooks do not turn on their external displays automatically when connected to a projector. You may have to adjust your notebook's projection settings.

VGA Out Connection

After establishing the VGA Connection, connect one end of a VGA cable to the VGA port of your monitor. Then connect the other end of the cable to the **MONITOR OUT** port of your projector.

Connecting to Audio

The projector is equipped with speakers, however, you can also connect external speakers to the **AUDIO OUT** port of the projector.

NOTE: The audio output is controlled by the projector's **Volume** and **Mute** settings.

Connecting to HDBaseT Device

HDBaseT is a technology to transmit image signal through a LAN cable. Connect Cat5e/Cat6 cable from HDBaseT TX Box for HDBaseT signal received.

Video Signal - Connect it to HDBaseT output equipment (Such as high-definition TV source, Blu-ray Player....etc).

RS-232 Function: When the projector connects to HDBaseT by RS-232 communication, the projector can be controlled with RS-232 commands from the computer. For details of RS232 commands, refer to RS-232 Communication command table.

HDBaseT best practice:

1. When in doubt, use shielded Cat6 with shielded plugs.
2. Use proper grounding.
3. Isolate HDBaseT cat cables from other signal types.

The connection illustrations below are for reference only. The connecting jacks available on the projector vary with each projector model. Some cables may not be included with the projector. They are commercially available from electronics stores.

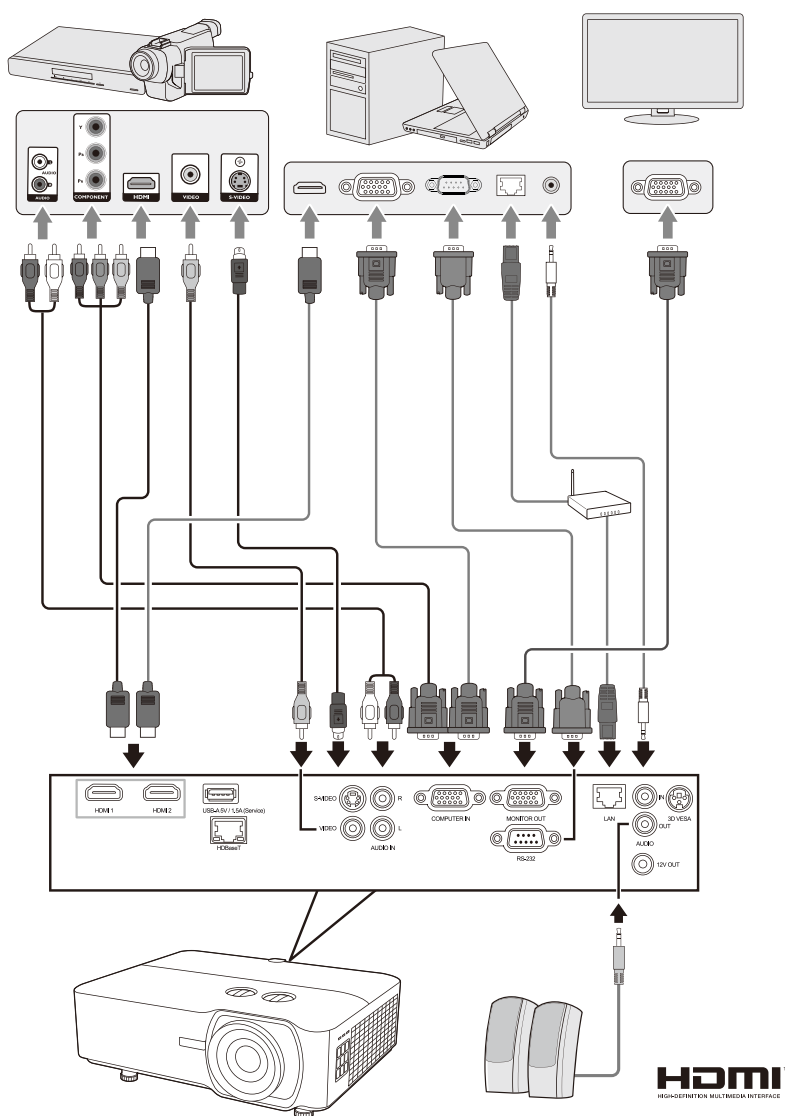

> Operation

Turning the Projector On/Off

Starting Up the Projector

1. Press the **Power** button to turn on the projector.
2. The light source will light up, and a “**Power On/Off Ring Tone**” will play.
3. The Power Indicator Light stays green when the projector is On.

NOTE: To maintain light source life, once you turn the projector On, wait at least five (5) minutes before turning it off.

4. Turn on all of the connected equipment, i.e. notebook, and the projector will start to search for an input source.

NOTE: If the projector detects an input source, the source information will appear. If an input source is not detected, the message, ‘No Signal’ will appear.

First Time Activation

If the projector is activated for the first time, select your OSD language following the on-screen instructions.



Shutting Down the Projector

1. Press the **Power** or **Off** button and a confirmation message will appear to prompt you to press the **Power** or **Off** button a second time. Additionally you can press any other button to cancel.

NOTE: If you do not respond in a few seconds after the first press, the message will disappear.

2. Once the cooling process finishes, a **“Power On/Off Ring Tone”** will play.
3. Disconnect the power cord from the power outlet if the projector will not be used for an extended period of time.

NOTE:

- To protect the light source, the projector will not respond to commands during the cooling process.
- Do not unplug the power cord before the projector completely shuts down.

Selecting an Input Source

The projector can be connected to multiple devices at the same time. However, it can only display one full screen at a time.

If you want the projector to automatically search for the input source, ensure the **Quick Auto Search** function in the **SYSTEM** menu is **On**.

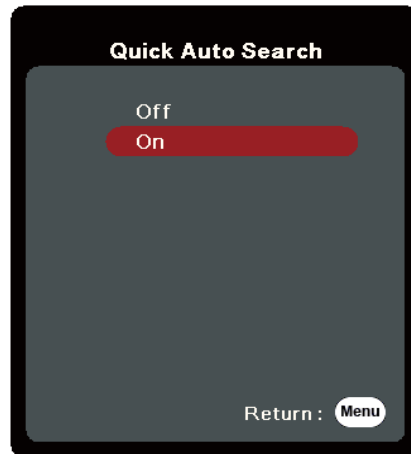

The **Input Source** can also be manually selected by pressing one of the source selection buttons on the remote control, or by cycling through the available input sources.

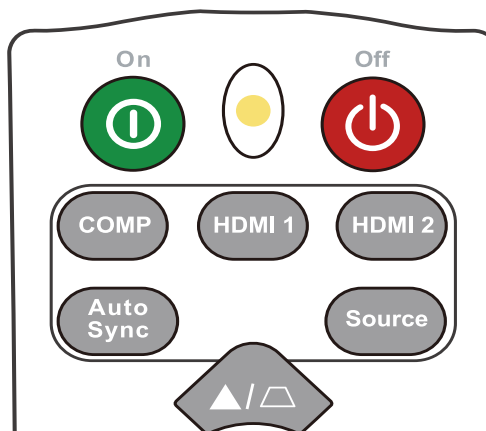

To manually select the input source do the following:

1. Press **Source**, and a source selection menu will appear.
2. Press **▲/▼** until your desired signal is selected and press **Enter**.
3. Once detected, the selected source information will be displayed on the screen for a few seconds.

NOTE: If there are multiple devices connected to the projector, repeat steps 1-2 to search for another source.

Adjusting the Projected Image

Adjusting the Projector's Height and Projection Angle

The projector is equipped with one (1) adjuster foot. Adjusting the foot will change the projector's height and the vertical projection angle. Carefully adjust the feet to fine tune the projected image's position.

Auto-Adjusting the Image

Sometimes, you may need to improve the picture quality. To do this, press **Auto Sync** on the remote control. Within five (5) seconds, the built-in Intelligent Auto Adjustment function will re-adjust the Frequency and Clock values to provide the best picture quality.

Upon completion, the current source information will appear in the upper left corner for three (3) seconds.

NOTE: This function is only available when the PC D-Sub input source (analog RGB/ COMPUTER IN) is selected.

Fine-Tuning the Image Size and Clarity

To adjust the projected image to the size that you need, rotate the Zoom Ring.

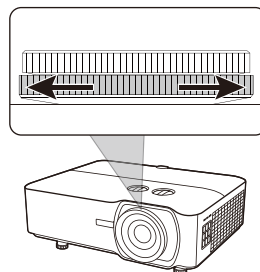
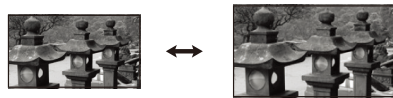



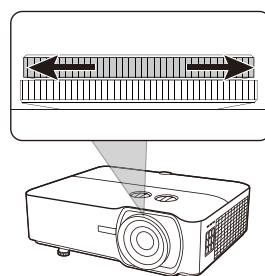
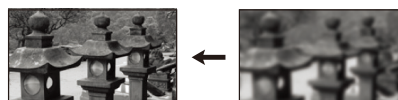

To improve the clarity of the image, rotate the Focus Ring.



Correcting Keystone

Keystoning refers to the situation where the projected image becomes a trapezoid due to angled projection.

To correct this, besides adjusting the height of the projector, you may also:

1. Use the keystone keys on the projector or remote control to display the keystone page.
2. After the keystone page is displayed, press  to correct keystone at the top of the image. Press  to correct keystone at the bottom of the image. Press  to correct keystone at the right side of the image. Press  to correct keystone at the left side of the image.

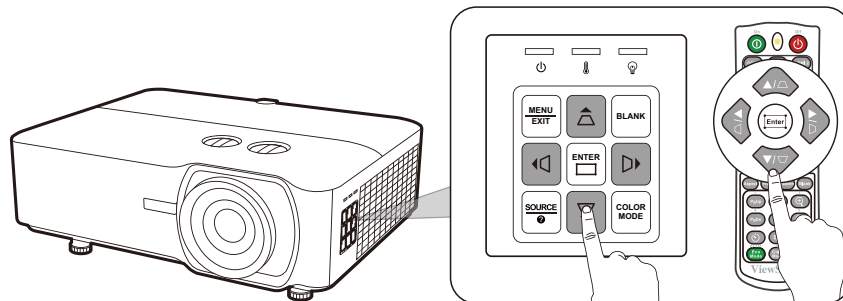
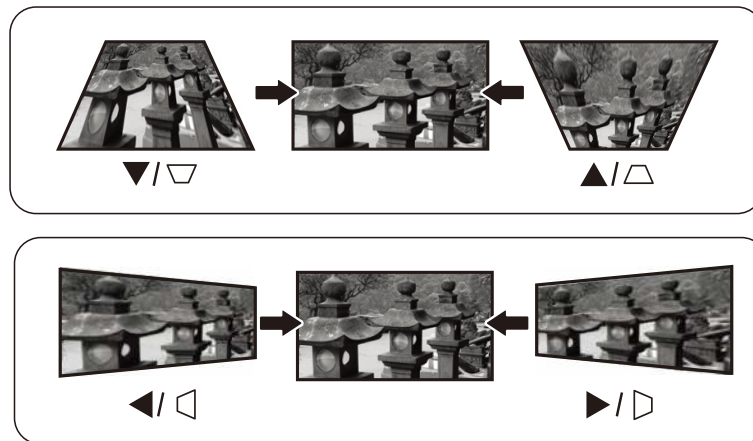

Controllability of the Projected Image

By using the lens shift knobs on the projector, you can adjust the vertical lens shift by +/- 50% or horizontal lens shift by +/-50%, which offers the convenience of not needing to physically move or interact with the projector. This is especially important when the projector is mounted to the ceiling.

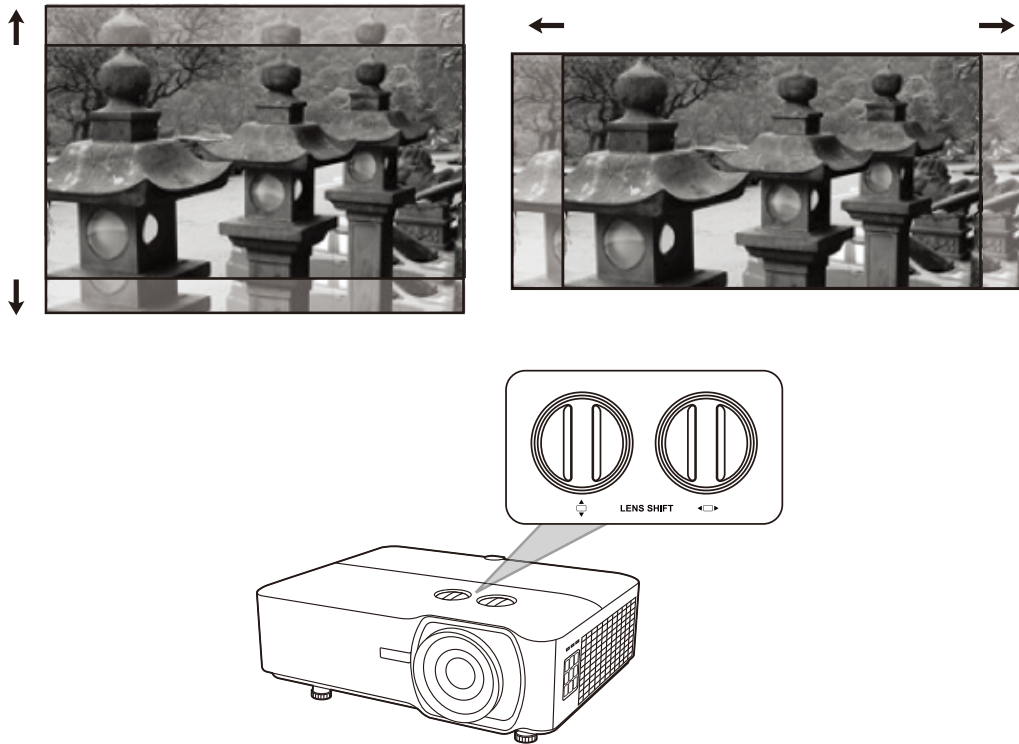

Hiding the Image

In order to draw the audience's full attention to the presenter, you can press **Blank** on the projector or remote control to hide the screen image. Press any key on the projector or remote control to restore the image.

CAUTION: Do not block the projection lens as this could cause the blocking object to become heated and deformed or even cause a fire.

Controlling the Projector through a LAN Environment

The projector supports Crestron® software. With correct settings for the LAN Control Settings menu, you can manage the projector from a computer using a web browser when the computer and the projector are properly connected to the same local area network.

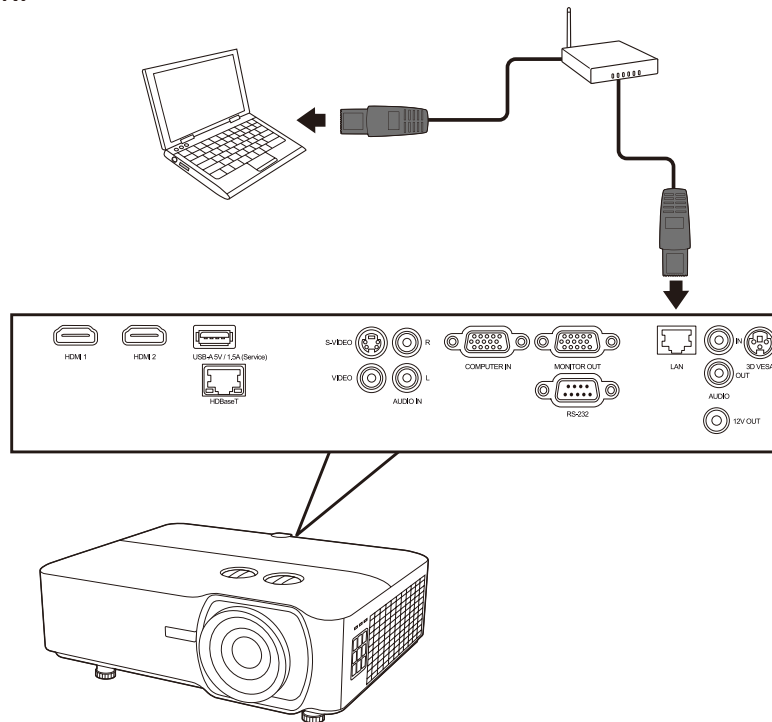

Configuring the LAN Control Settings

- If you are in a DHCP environment:
1. Take a RJ45 cable and connect one end to the RJ45 LAN input jack of the projector and the other end to the RJ45 port.
 2. Open the OSD menu and go to the **ADVANCED > LAN Control Settings** menu. Press **Enter** to display the **LAN Control Settings** page. Or you can press **Network** to open the **LAN Control Settings** menu directly.
 3. Highlight **LAN Settings** and press **◀ / ▶** to select **DHCP ON**.
 4. Press **▼** to highlight **Apply** and press **Enter**.
 5. Please wait for around 15 - 20 seconds, and then re-enter the **LAN Settings** page. The **Projector IP Address**, **Subnet Mask**, **Default Gateway**, **DNS Server** settings will be displayed. Make note of the IP address displayed in the **Projector IP Address** row.

NOTE:

- If the **Projector IP Address** still does not appear, contact your network administrator.
- If the RJ45 cables are not properly connected, the **Projector IP Address**, **Subnet Mask**, **Default Gateway** and **DNS Server** settings will display 0.0.0.0. Make

sure the cables are properly connected and perform the procedures above again.

- If you need to connect to the projector in its standby mode, set **Standby LAN Control** to **On** in the **ADVANCED > LAN Control Settings** menu.

- If you are in a non-DHCP environment:

1. Repeat steps 1-2 above.
2. Highlight **LAN Settings** and press ◀/▶ to select **Static IP**.
3. Contact your ITS administrator for information on the **Projector IP Address, Subnet Mask, Default Gateway, DNS Server** settings.
4. Press to select the item you want to modify and press **Enter**.
5. Press ◀/▶ to move the cursor and the press ▲/▼ to enter the value.
6. To save the settings, press **Enter**. If you do not want to save the settings, press **Exit**.
7. Press ▼ to highlight **Apply** and press **Enter**.

NOTE:

- If the RJ45 cables are not properly connected, the **Projector IP Address, Subnet Mask, Default Gateway, DNS Server** settings will display 0.0.0.0. Make sure the cables are properly connected and perform the procedures above again.
- If you wish to connect to the projector in its standby mode, be sure you have selected **Static IP** and obtained the **Projector IP Address, Subnet Mask, Default Gateway** and **DNS Server** information when the projector is on.

> Menu Functions

This section will introduce the On-Screen Display (OSD) Menu and its options.

General On-Screen Display (OSD) Menu Operation

NOTE: The OSD screenshots in this manual are for reference only and may differ from the actual design. Some of the following OSD settings may not be available. Please refer to the actual OSD of your projector.

The projector is equipped with an On-Screen Display (OSD) Menu for making various adjustments. It can be accessed by pressing **Menu** on the projector or remote control.

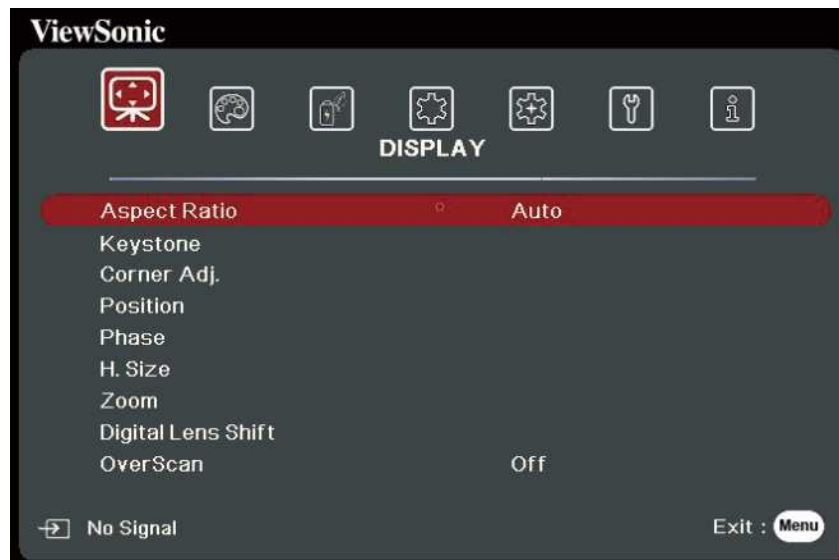

1. Press ◀/▶ to select a main menu. Then press **Enter** or use ▲/▼ to access the sub-menu list.
2. Press ▲/▼ to select the menu option. Then press **Enter** to display its sub-menu, or press ◀/▶ to adjust/select the setting.

NOTE: Some sub-menu options may have another sub-menu. To enter the respective sub-menu, press **Enter**. Use ▲/▼ or ◀/▶ to adjust/select the setting.

On-Screen Display (OSD) Menu Tree

| Main Menu | Sub-menu | Menu Option | |
|------------|--------------------|----------------------|---------|
| DISPLAY | Aspect Ratio | Auto | |
| | | 4:3 | |
| | | 16:9 | |
| | | 16:10 | |
| | | 2.35:1 | |
| | | Native | |
| | Keystone | Vertical | -40~40 |
| | | Horizontal | -40~40 |
| | Corner Adj. | Top-Right | 45°/90° |
| | | Top-Left | 45°/90° |
| | | Bottom-Right | 45°/90° |
| | | Bottom-Left | 45°/90° |
| | Position | X: -5 ~ 5, Y: -5 ~ 5 | |
| | Phase | 0~31 | |
| | H. Size | -15~15 | |
| | Zoom | 0.8X ~2.0X | |
| | Digital Lens Shift | Vertical | -50~50 |
| Horizontal | | -50~50 | |
| OverScan | Off/1/2/3/4/5 | | |
| IMAGE | Color Mode | Brightest | |
| | | Presentation | |
| | | Standard | |
| | | Photo | |
| | | Movie | |
| | | User 1 | |
| | | User 2 | |
| | Brightness | 0~100 | |
| Contrast | -50~50 | | |

| Main Menu | Sub-menu | Menu Option | | | |
|-----------|----------------------|-------------------|-------------------------------------|--|--|
| IMAGE | Color Temp. | 9300K/7500K/6500K | | | |
| | | Red Gain | 0~100 | | |
| | | Green Gain | 0~100 | | |
| | | Blue Gain | 0~100 | | |
| | | Red Offset | -50~+50 | | |
| | | Green Offset | -50~+50 | | |
| | | Blue Offset | -50~+50 | | |
| | Advanced | Color | -50~50 | | |
| | | Tint | -50~50 | | |
| | | Sharpness | 0~31 | | |
| | | Gamma | 1.8/2.0/2.2/2.35/ 2.5/Cubic/sRGB | | |
| | | Brilliantcolor | Off/1/2/3/4/ 5/6/7/8/9/10 | | |
| | | Noise Reduction | 0~31 | | |
| | | Color Management | Primary Color | | |
| | | | Hue | | |
| | | | Saturation | | |
| | | | Gain | | |
| | Reset Color Settings | Reset | | | |
| | | Cancel | | | |

| Main Menu | Sub-menu | Menu Option | | |
|-------------------------|------------------|--------------------|---|--|
| POWER MANAGEMENT | Auto Power On | Signal | Disable/VGA/HDMI/All | |
| | | CEC | Disable/Enable | |
| | | Direct Power On | Disable/Enable | |
| | Smart Energy | Auto Power Off | Disable/10 min/20 min/30 min | |
| | | Sleep Timer | Disable/30 min/1 hr/2hr/3 hr/4 hr/ 8 hr/12 hr | |
| | | Power Saving | Disable/Enable | |
| | Standby Settings | VGA Loop Through | Off/On | |
| | | Audio Pass Through | Off/On | |
| | USB A Power | On | | |
| | | Off | | |

| Main Menu | Sub-menu | Menu Option | | | | |
|-----------------|--------------------|--|---|--|--|--|
| BASIC | Audio Settings | Mute | Off/On | | | |
| | | Audio Volume | 0~20 | | | |
| | | Power On/Off Ring Tone | Off/On | | | |
| | Presentation Timer | Timer Period | 1~240 m | | | |
| | | Timer Display | Always/1 min/2 min/3 min/Never | | | |
| | | Timer Position | Top-Left/Bottom-Left/Top-Right/Bottom-Right | | | |
| | | Timer Counting Direction | Count Down/Count Up | | | |
| | | Sound Reminder | Off/On | | | |
| | | Start Counting/Off | | | | |
| | Pattern | Off | | | | |
| | | Test Card | | | | |
| | Blank Timer | Disable/5 min/10 min/15 min/20 min/25 min/30 min | | | | |
| | Message | Off | | | | |
| | | On | | | | |
| | Splash Screen | Black | | | | |
| | | Blue | | | | |
| | | ViewSonic | | | | |
| ADVANCED | 3D Settings | 3D Glasses | | | | |
| | | 3D Format | Auto | | | |
| | | | Off | | | |
| | | | Frame Sequential | | | |
| | | | Frame Packing | | | |
| | | | Top-Bottom | | | |
| | | | Side-by-Side | | | |
| | | 3D Sync Invert | Disable/Invert | | | |
| | Save 3D Settings | Yes/No | | | | |
| | HDMI Settings | HDMI Format | Auto/RGB/YUV | | | |
| HDMI Range | | Auto/Enhanced/Normal | | | | |

| Main Menu | Sub-menu | Menu Option | |
|-----------|-----------------------|--------------------------------|-----------------------------------|
| ADVANCED | HDR/HLG | HDR/HLG | Auto/SDR |
| | | EOTF | Low/Mid/High |
| | 3X Fast Input | Inactive | |
| | | Active | |
| | LAN Control Settings | LAN Settings | DHCP ON/Static IP |
| | | Projector IP Address | |
| | | Subnet Mask | |
| | | Default Gateway | |
| | | DNS Server | |
| | | Standby LAN Control | Off/On |
| | | Apply | |
| | Light Source Settings | Light Source Mode | Normal/Eco/ Dynamic Eco/Custom |
| | | Light Source Power | 20%~100% |
| | | Reset Light Source Hours | Reset/Cancel |
| | | Light Source Hours Information | Light Source Usage Time |
| | | | Normal |
| | | | Eco |
| | | | Dynamic Eco |
| | Custom | | |
| | Closed Caption | Closed Caption Enable | Off/On |
| | | Caption Version | CC1/CC2/CC3/CC4 |
| | Reset Settings | Reset | |
| | | Cancel | |

| Main Menu | Sub-menu | Menu Option | | |
|---------------|---------------------|--|--|----------------------------|
| SYSTEM | Language | Multi-Language OSD Selection | | |
| | Projector Position | Front Table | | |
| | | Rear Table | | |
| | | Rear Ceiling | | |
| | | Front Ceiling | | |
| | Menu Settings | Menu Display Time | 5 sec/10 sec/15 sec/20 sec/25 sec/30 sec | |
| Menu Position | | Center/Top-Left/Top-Right/Bottom-Left/Bottom-Right | | |
| SYSTEM | High Altitude Mode | Off | | |
| | | On | | |
| | Quick Auto Search | Off | | |
| | | On | | |
| | Security Settings | Change Password | | |
| | | Power On Lock | | Off/On |
| | Panel Key Lock | Off | | |
| | | On | | |
| | Remote Control Code | 1/2/3/4/5/6/7/8 | | |
| | Control Method | RS-232 | | |
| | | USB | | |
| | | HDBaseT | | (only for LS920WU/LS921WU) |
| | Baud Rate | 2400/4800/9600/14400/19200/38400/57600/115200 | | |

| Main Menu | Sub-menu | Menu Option |
|--------------------|------------------|-------------|
| INFORMATION | Source | |
| | Color Mode | |
| | Resolution | |
| | Color System | |
| | IP address | |
| | MAC address | |
| | Firmware Version | |
| | 3X Fast Input | |
| | S/N | |

DISPLAY Menu

1. Press the **Menu** button to display the On-Screen Display (OSD) Menu.
2. Press ◀/▶ to select the **DISPLAY** menu. Then press **Enter** or use ▲/▼ to access the **DISPLAY** menu.



3. Press ▲/▼ to select the menu option. Then press **Enter** to display its sub-menu, or press ◀/▶ to adjust/select the setting.

NOTE: Some sub-menu options may have another sub-menu. To enter the respective sub-menu, press **Enter**. Use ▲/▼ or ◀/▶ to adjust/select the setting.

| Menu Option | Description |
|--------------|---|
| Aspect Ratio | <p><u>Auto</u> Scales an image proportionally to fit the projector's native resolution in its horizontal width. This is suitable for the incoming image which is neither in 4:3 nor 16:9 and you want to make most use of the screen without altering the image's aspect ratio.</p> <p><u>4:3</u> Scales an image so that it is displayed in the center of the screen with a 4:3 aspect ratio. This is most suitable for 4:3 images like computer monitors, standard definition TV, and 4:3 aspect DVD movies, as it displays them without aspect alteration.</p> <p><u>16:9</u> Scales an image so that it is displayed in the center of the screen with a 16:9 aspect ratio. This is most suitable for images which are already in a 16:9 aspect, like high definition TV, as it displays them without aspect alteration.</p> <p><u>16:10</u> Scales an image so that it is displayed in the center of the screen with a 16:10 aspect ratio. This is most suitable for images which are already in a 16:10 aspect, as it displays them without aspect alteration.</p> <p><u>2.35:1</u> Scales an image so that it is displayed in the center of the screen with a 2.35:1 aspect ratio. This is most suitable for images which are already in a 2.35:1 aspect, as it displays them without aspect alteration.</p> <p><u>Native</u> Projects an image as its original resolution and resizes it to fit within the display area. For input signals with lower resolutions, the projected image will be displayed in its original size.</p> |
| Keystone | Adjusts the keystone situation where the projected image becomes a trapezoid due to angled projection. |
| Corner Adj. | Adjusts the shape and size of an image that is unevenly rectangular on all sides. |

| Menu Option | Description |
|--------------------|--|
| Position | Adjust the position of the projected image. NOTE: <ul style="list-style-type: none"> • This function is only available when a PC input signal is selected. • The adjustment range may vary under different timings. |
| Phase | Adjusts the clock phase to reduce image distortion. NOTE: This function is only available when a PC input signal is selected. |
| H. Size | Adjusts the horizontal width of the image. NOTE: This function is only available when a PC input signal is selected. |
| Zoom | Magnifies the projected image and allows you to navigate the image. |
| Digital Lens Shift | You can adjust the vertical lens shift by +/- 50% or horizontal lens shift by +/-50%, which offers the convenience of not needing to physically move or interact with the projector. NOTE: This function is only available when the image is zoomed out. |
| OverScan | Adjusts the overscan rate from 0% to 5%. NOTE: This function is only available when a Composite Video or HDMI input signal is selected. |





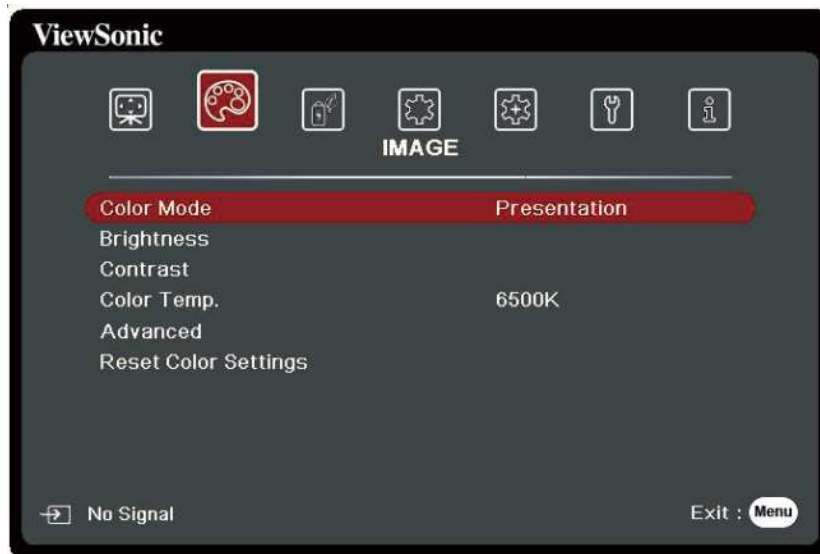

IMAGE Menu

1. Press the **Menu** button to display the On-Screen Display (OSD) Menu.
2. Press ◀/▶ to select the **IMAGE** menu. Then press **Enter** or use ▲/▼ to access the **IMAGE** menu.



3. Press ▲/▼ to select the menu option. Then press **Enter** to display its sub-menu, or press ◀/▶ to adjust/select the setting.

NOTE: Some sub-menu options may have another sub-menu. To enter the respective sub-menu, press **Enter**. Use ▲/▼ or ◀/▶ to adjust/select the setting.

| Menu Option | Description |
|-------------|---|
| Color Mode | <p><u>Brightest</u> Maximizes the brightness of the projected image. This mode is suitable for environments where extra-high brightness is required, such as using the projector in well lit rooms.</p> <p><u>Presentation</u> Designed for presentations under daylight environment to match PC and notebook coloring.</p> <p><u>Standard</u> Designed for normal circumstances in a daylight environment.</p> <p><u>Photo</u> Designed for photo viewing.</p> <p><u>Movie</u> For playing colorful movies, video clips from digital cameras or DVs through the PC input for best viewing in a blackened (little light) environment.</p> <p><u>User 1/User 2</u> Recalls the customized settings. After User 1/User 2 is selected, some of the sub-menus under the IMAGE menu can be adjusted, according to your selected input source.</p> |
| Brightness | <p>The higher the value, the brighter the image. Adjust this option so the black areas of the image appear just as black and details in the dark area are more visible.</p> <div style="display: flex; justify-content: space-around; align-items: flex-end;">    </div> |
| Contrast | <p>Use this to set the peak white level after you have previously adjusted the Brightness setting.</p> <div style="display: flex; justify-content: space-around; align-items: flex-end;">    </div> |

| Menu Option | Description |
|-------------|--|
| Color Temp. | <p><u>9300K</u> Images appear bluish white.</p> <p><u>7500K</u> Images maintain a normal white appearance.</p> <p><u>6500K</u> Images appear reddish white.</p> <p>To set a custom color temperature, you can further adjust the following items:</p> <p><u>Red Gain/Green Gain/Blue Gain</u> Adjusts the Contrast levels of Red, Green, and Blue.</p> <p><u>Red Offset/Green Offset/Blue Offset</u> Adjusts the Brightness levels of Red, Green, and Blue.</p> |
| Advanced | <p><u>Color</u> A lower setting produces less saturated colors. If the setting is too high, colors will be overpowering and may appear unrealistic.</p> <p><u>Tint</u> A higher value will make the picture more greenish while a lower value will make the picture more reddish.</p> <p><u>Sharpness</u> A higher value will sharpen the image, while a lower value will soften the image.</p> <p><u>Gamma</u> Gamma refers to the brightness level of the projector's grayscale levels.</p> <p><u>Brilliantcolor</u> This feature utilizes a new color-processing algorithm and system level enhancements to enable higher brightness while providing truer, more vibrant colors in the projected picture. It enables a greater than 50% brightness increase in mid-tone images, which are common in video and natural scenes, so the projector reproduces images in realistic and true colors. If you prefer images with that quality, select a level that suits your need.</p> |

| Menu Option | Description |
|----------------------|---|
| Advanced | <p><u>Noise Reduction</u> This function reduces electrical image noise caused by different media players. The higher the setting, the less the noise. (Not available when input signal is HDMI.)</p> <p><u>Color Management</u> Only in permanent installations with controlled lighting levels such as boardrooms, lecture theaters, or home theaters, should color management be considered. Color management provides fine color control adjustment to allow for more accurate color reproduction. Select Primary Color first and adjust its range/values in Hue, Saturation and Gain.</p> |
| Reset Color Settings | Returns current image settings to the factory preset values. |

POWER MANAGEMENT Menu

1. Press the **Menu** button to display the On-Screen Display (OSD) Menu.
2. Press ◀/▶ to select the **POWER MANAGEMENT** menu. Then press **Enter** or use ▲/▼ to access the **POWER MANAGEMENT** menu.



3. Press ▲/▼ to select the menu option. Then press **Enter** to display its sub-menu, or press ◀/▶ to adjust/select the setting.

NOTE: Some sub-menu options may have another sub-menu. To enter the respective sub-menu, press **Enter**. Use ▲/▼ or ◀/▶ to adjust/select the setting.

| Menu Option | Description |
|---------------|--|
| Auto Power On | <p><u>Signal</u> Selecting VGA/HDMI allows the projector to turn on automatically once the VGA/HDMI signal is fed through the VGA/HDMI cable. You can also select All and the projector will turn on automatically upon receiving either a VGA or HDMI signal.</p> <p><u>CEC</u> This projector supports CEC (Consumer Electronics Control) function for synchronized power on/off operation via HDMI connection. That is, if a device that also supports CEC function is connected to the HDMI input of the projector, when the projector's power is turned off, the power of the connected device will also be turned off automatically. When the power of the connected device is turned on, the projector's power will be turned on automatically.</p> <p>NOTE:</p> <ul style="list-style-type: none"> • In order for the CEC function to work properly, make sure that the device is correctly connected to the HDMI input of the projector via an HDMI cable, and its CEC function is turned on. • Depending on the connected device, the CEC function may not work. <p><u>Direct Power On</u> Allows the projector to turn on automatically once power is fed through the power cord.</p> |
| Smart Energy | <p><u>Auto Power Off</u> Allows the projector to turn off automatically after a set period of time once no input source is detected to prevent unnecessary waste of light source life.</p> <p><u>Sleep Timer</u> Allows the projector to turn off automatically after a set period of time to prevent unnecessary waste of light source life.</p> <p><u>Power Saving</u> Lowers power consumption if no input source is detected. When Enable is selected, the projector will change to Power Saving mode after no signal is detected for five (5) minutes. This will also help prevent any unnecessary waste of light source life.</p> |

| Menu Option | Description |
|------------------|--|
| Standby Settings | <p>The functions below are available in standby mode (plugged in, but not turned on).</p> <p><u>VGA Loop Through</u> When selecting On, the projector outputs the signal received only from COMPUTER IN.</p> <p><u>Audio Pass Through</u> When selecting On, the projector outputs an audio signal when the Audio In and Audio Out sockets are correctly connected to a proper device.</p> |
| USB A Power | When On, the USB Type A port can supply power, and the Control Method will automatically switch to RS-232. |

BASIC Menu

1. Press the **Menu** button to display the On-Screen Display (OSD) Menu.
2. Press ◀/▶ to select the **BASIC** menu. Then press **Enter** or use ▲/▼ to access the **BASIC** menu.



3. Press ▲/▼ to select the menu option. Then press **Enter** to display its sub-menu, or press ◀/▶ to adjust/select the setting.

NOTE: Some sub-menu options may have another sub-menu. To enter the respective sub-menu, press **Enter**. Use ▲/▼ or ◀/▶ to adjust/select the setting.

| Menu Option | Description |
|--------------------|--|
| Audio Settings | <p><u>Mute</u> Select On to temporarily turn off the projector's internal speaker or the volume being output from the audio output jack.</p> <p><u>Audio Volume</u> Adjusts the volume level of the projector's internal speaker or the volume being output from the audio output jack.</p> <p><u>Power On/Off Ring Tone</u> Turns on/off the ring tone during the starting up and shutting down process.</p> |
| Presentation Timer | <p>Presentation timer can indicate the presentation time on the screen to help you achieve better time management when giving presentations.</p> <p><u>Timer Period</u> Sets the time period. If the timer is already on, the timer will restart whenever the Timer Period is reset.</p> <p><u>Timer Display</u> Allows you to decide if you want the timer to show up on the screen for one of the following time periods:</p> <ul style="list-style-type: none"> » Always: Displays the timer on screen throughout the presentation time. » 1 min/2 min/3 min: Displays the timer on screen in the last 1/2/3 minute(s). » Never: Hides the timer throughout the presentation time. <p><u>Timer Position</u> Sets the timer position.</p> <p><u>Timer Counting Direction</u> Sets your desired counting direction between:</p> <ul style="list-style-type: none"> » Count Down: Decreases from the preset time to 0. » Count Up: Increases from 0 to the preset time. <p><u>Sound Reminder</u> Allows you to decide if you want to activate a sound reminder. Once enabled, a double beep sound will be heard at the last 30 seconds of counting down/up, and a triple beep sound will be produced when the timer is up.</p> <p><u>Start Counting/Off</u> Select Start Counting to activate the timer. Select Off to cancel it.</p> |
| Pattern | Helps adjust the image size and focus, and checks for distortion in the projected image. |

| Menu Option | Description |
|---------------|--|
| Blank Timer | <p>Allows the projector to return the image automatically after a period of time when there is no action taken on the blank screen. To display the blank screen, press Blank on the projector or remote control.</p> <p>NOTE: Do not block the projection lens as this could cause the blocking object to become heated and deformed or even cause a fire.</p> |
| Message | Sets reminder messages, i.e. “Blank” message, On or Off. |
| Splash Screen | Selects which logo screen will appear during projector start-up. |

ADVANCED Menu

1. Press the **Menu** button to display the On-Screen Display (OSD) Menu.
2. Press ◀/▶ to select the **ADVANCED** menu. Then press **Enter** or use ▲/▼ to access the **ADVANCED** menu.

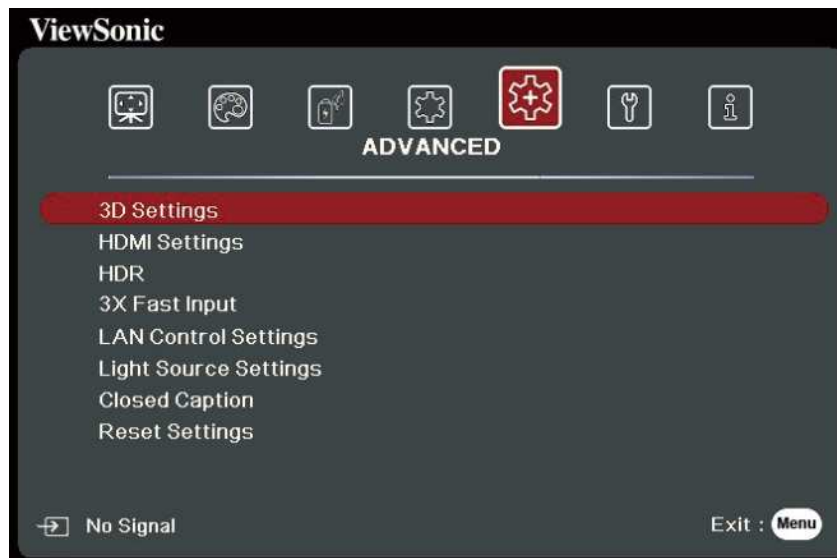

3. Press ▲/▼ to select the menu option. Then press **Enter** to display its sub-menu, or press ◀/▶ to adjust/select the setting.

NOTE: Some sub-menu options may have another sub-menu. To enter the respective sub-menu, press **Enter**. Use ▲/▼ or ◀/▶ to adjust/select the setting.

| Menu Option | Description |
|---------------|--|
| 3D Settings | <p>This projector features a 3D function which enables you to enjoy 3D movies, videos, and sporting events in a more realistic way by presenting the depth of the images. You need to wear a pair of 3D glasses to view 3D images.</p> <p><u>3D Glasses</u> Chooses the appropriate type of 3D glasses.</p> <p><u>3D Format</u> The default setting is Auto and the projector automatically chooses an appropriate 3D format when detecting 3D contents. If the projector cannot recognize the 3D format, choose a 3D mode.</p> <p><u>3D Sync Invert</u> When you discover the inversion of the image depth, enable this function to correct the problem.</p> <p><u>Save 3D Settings</u> Saves current 3D settings. 3D settings will automatically be applied if the same resolution and input source are selected.</p> <p>NOTE: When the 3D Sync function is on:</p> <ul style="list-style-type: none"> • The brightness level of the projected image will decrease. • The Color Mode, Light Source Mode, Zoom, and OverScan cannot be adjusted. |
| HDMI Settings | <p><u>HDMI Format</u> Select a suitable color space according to the color space setting of the output device connected.</p> <ul style="list-style-type: none"> » Auto: Sets the projector to detect the color space setting of the input signal automatically. » RGB: Sets the color space as RGB. » YUV: Sets the color space as YUV. <p><u>HDMI Range</u> Select a suitable HDMI color range according to the color range setting of the output device connected.</p> <ul style="list-style-type: none"> » Auto: Sets the projector to detect the HDMI range of the input signal automatically. » Enhanced: Sets the HDMI color range as 0 - 255. » Normal: Sets the HDMI color range as 16 - 235. |

| Menu Option | Description | | | | | |
|-----------------------------|---|-----------------------------|--|--------------------|------------------------|-------------------|
| HDR | <p><u>HDR/HLG</u> The projector supports HDR imaging sources. It can automatically detect the dynamic range of the source, and optimize image gamma and color settings to reproduce contents under wide range of light conditions. You also select SDR.</p> <p><u>EOTF</u> The projector can automatically adjust the brightness levels of your image according to the input source. Normally, the default setting “Mid” is recommended. If the brightness of the projected image is dark, please use “Low”. When giving priority to gradation property, please use “High”.</p> | | | | | |
| 3X Fast Input | <p>This function is favorable to frame rate reducing. Quick response time in native timing can be achieved. When enabled, the following settings will return to factory preset values: Aspect Ratio, Position, Zoom, OverScan.</p> <p>NOTE: This function is only available when a native timing input signal is selected.</p> | | | | | |
| LAN Control Settings | <p><u>LAN Settings</u></p> <ul style="list-style-type: none"> » DHCP ON: Select this if you are in a DHCP environment and Projector IP Address, Subnet Mask, Default Gateway, DNS Server settings will be automatically retrieved. » Static IP: Select this if you are in a non-DHCP environment and make adjustments to below settings. <table border="1" data-bbox="504 1301 1469 1514"> <tr> <td data-bbox="504 1301 847 1350"><u>Projector IP Address</u></td> <td data-bbox="847 1301 1469 1514" rowspan="4">Only available when <u>LAN Settings</u> is set to Static IP. Use ◀/▶ to select a column and use ▲/▼ to adjust the value.</td> </tr> <tr> <td data-bbox="504 1350 847 1400"><u>Subnet Mask</u></td> </tr> <tr> <td data-bbox="504 1400 847 1449"><u>Default Gateway</u></td> </tr> <tr> <td data-bbox="504 1449 847 1514"><u>DNS Server</u></td> </tr> </table> <p><u>Standby LAN Control</u> Allows the projector to provide the network function in standby mode.</p> <p><u>Apply</u> Enacts the settings.</p> | <u>Projector IP Address</u> | Only available when <u>LAN Settings</u> is set to Static IP. Use ◀/▶ to select a column and use ▲/▼ to adjust the value. | <u>Subnet Mask</u> | <u>Default Gateway</u> | <u>DNS Server</u> |
| <u>Projector IP Address</u> | Only available when <u>LAN Settings</u> is set to Static IP. Use ◀/▶ to select a column and use ▲/▼ to adjust the value. | | | | | |
| <u>Subnet Mask</u> | | | | | | |
| <u>Default Gateway</u> | | | | | | |
| <u>DNS Server</u> | | | | | | |

| Menu Option | Description |
|-----------------------|--|
| Light Source Settings | <p><u>Light Source Mode</u></p> <ul style="list-style-type: none"> » Normal: Provides full light source brightness. » Eco: Reduces light source power consumption by 30% and lowers brightness to decrease the fan noise. » Dynamic Eco: Reduces light source power consumption by up to 60% depending on the content brightness level. » Custom: Allows you to adjust the light source power. <p><u>Light Source Power</u> Only available when Light Source Mode is Custom.</p> <p><u>Reset Light Source Hours</u> Resets the light source timer after new light source is installed. For changing the light source, please contact qualified service personnel.</p> <p><u>Light Source Hours Information</u></p> <ul style="list-style-type: none"> » Light Source Usage Time: Displays the number of hours the light source has been used. |
| Closed Caption | <p><u>Closed Caption Enable</u> Activates the function when the selected input signal carries closed captions.</p> <p>NOTE:</p> <ul style="list-style-type: none"> • Captions: An on-screen display of the dialogue, narration, and sound effects of TV programs and videos that are closed captioned (usually marked as “CC” in TV listings). • This function is only available when a Composite video input signal is selected and its system format is NTSC. <p><u>Caption Version</u> To view captions, select CC1, CC2, CC3, or CC4 (CC1 displays captions in the primary language in your area).</p> |
| Reset Settings | <p>Returns all settings to the factory preset values. When using Reset Settings, the following settings will still remain: Keystone, Corner Adj., Zoom, Digital Lens Shift, USB A Power, Language, Projector Position, LAN Settings, High Altitude Mode, Security Settings, Remote Control Code, Control Method, 3D Glasses and Baud Rate.</p> |

SYSTEM Menu

1. Press the **Menu** button to display the On-Screen Display (OSD) Menu.
2. Press ◀/▶ to select the **SYSTEM** menu. Then press **Enter** or use ▲/▼ to access the **SYSTEM** menu.



3. Press ▲/▼ to select the menu option. Then press **Enter** to display its sub-menu, or press ◀/▶ to adjust/select the setting.

NOTE: Some sub-menu options may have another sub-menu. To enter the respective sub-menu, press **Enter**. Use ▲/▼ or ◀/▶ to adjust/select the setting.

| Menu Option | Description |
|---------------------|---|
| Language | Sets the language for the On-Screen Display (OSD) Menu. |
| Projector Position | Selects a proper position for the projector. |
| Menu Settings | <p><u>Menu Display Time</u> Sets the length of time the OSD Menu will remain active after your last interaction.</p> <p><u>Menu Position</u> Sets the OSD Menu's position.</p> |
| High Altitude Mode | <p>We recommend you use the High Altitude Mode when your environment is between 1,500 m to 3,000 m above sea level, and ambient temperature is between 5°C–25°C.</p> <p>NOTE:</p> <ul style="list-style-type: none"> • Do not use High Altitude Mode if your environment is between 0 to 1,499 m, and the temperature is between 5°C to 35°C. If used, the projector will become over cooled. • Using “High Altitude Mode” may cause more operating noise, as the fan speed will be increased to improve cooling and performance. |
| Quick Auto Search | Allows the projector to automatically search for the signals. |
| Security Settings | See “Using the Password Function” on page 19. |
| Panel Key Lock | Locks the control keys on the projector. |
| Remote Control Code | <p>Sets the remote control code for this projector (between 1~8). When multiple adjacent projectors are in operation at the same time, switching the codes can prevent interference from other remote controls. After the remote control code is set, switch to the same ID for the remote control to control this projector. To switch the code for the remote control, press ID set and the number button corresponding to the remote control code together for 5 seconds or more. The initial code is set to 1. When the code is switched to 8, the remote control can control every projector.</p> <p>NOTE: If different codes are set on the projector and remote control, there will be no response from the remote control. When that happens, a message will display to remind you to switch the code for the remote control.</p> |
| Control Method | Allows you to select a preferred control port: through the RS-232 port, the USB port or the HDBaseT port. When selecting USB, USB A Power will be switched to Off automatically. |
| Baud Rate | Selects a baud rate that is identical with your computer's so that you can connect the projector using a suitable RS-232 cable and control the projector with RS-232 commands |

INFORMATION Menu

1. Press the **Menu** button to display the On-Screen Display (OSD) Menu.
2. Press ◀/▶ to select the **INFORMATION** menu and display its contents.

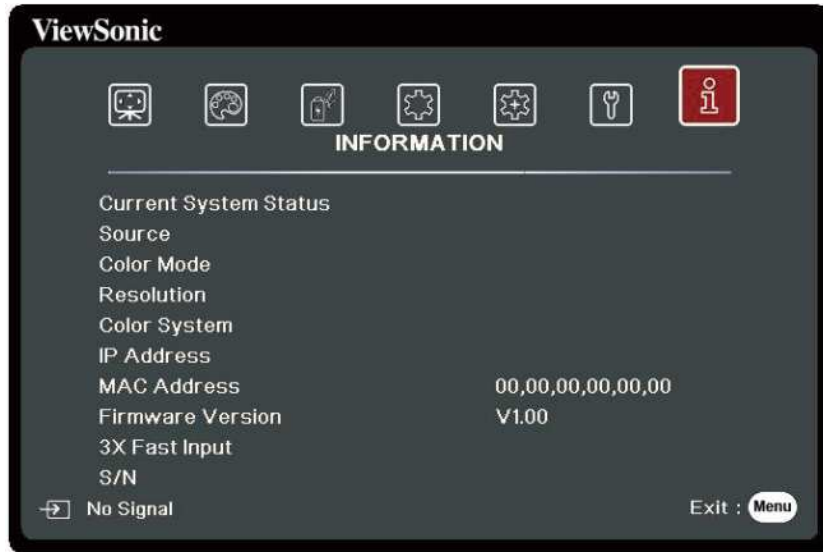

| Menu Option | Description |
|------------------|--|
| Source | Shows the current input source. |
| Color Mode | Shows the selected mode in the IMAGE menu. |
| Resolution | Shows the native resolution of the input source. |
| Color System | Shows input system format. |
| IP address | Shows the IP address of your projector. |
| MAC address | Shows the MAC Address of your projector. |
| Firmware Version | Shows the current firmware version. |
| 3X Fast Input | Shows whether the function is activated or not. |
| S/N | Shows the serial number for this projector. |

> Appendix

Specifications

| Item | Category | LS920WU | LS921WU |
|----------------------------|----------------------|--|----------------------------------|
| Projector | Type | Laser | |
| | Display Size | 30" ~ 300" | |
| | Throw Ratio | 1.36~2.18 (87"±3%@2.54m) | 0.81~0.89 (87"±3%@2.54m) |
| | Lens | 1.6x±2% Optical Zoom | 1.1x±2% Optical Zoom |
| | Light Source Type | NUBM38 74W 455nm x 2 | |
| | Display System | 1-CHIP DMD | |
| Input Signal | VGA | f_h : 15K~102KHz, f_v :48~120Hz, Pixel rate: 170MHz | |
| | HDMI | f_h : 15K~102KHz, f_v :23~120Hz, Pixel rate: 170MHz | |
| Resolution | Native | 1920 x 1200 | |
| Power Adapter ¹ | Input Voltage | AC 100-240V, 50/60 Hz (auto switch) | |
| Operating conditions | Temperature | 0°C to 40°C (32°F to 104°F) | |
| | Humidity | 10% to 90% (non-condensing) | |
| | Altitude | 0 to 1,499 m at 0°C to 35°C 1,500 to 3,000 m at 0°C to 25°C | |
| Storage conditions | Temperature | -20°C to 60°C (non-condensing) | |
| | Humidity | 10% to 90% (non-condensing) | |
| | Altitude | 0 to 40,000 ft sea level at 30°C | |
| Dimensions | Physical (W x D x H) | 405 mm x 305 mm x 144 mm (15.9" x 12" x 5.7") | |
| Weight | Physical | 6.4kg (Gross weight : 8.9 kg) | 6.4kg (Gross weight : 9.1 kg) |
| Power Saving Modes | On ² | 445W (Typical) | |
| | Off | < 0.5W (Standby) | |

¹ Please use the power adapter from ViewSonic® or an authorized source only.

² The test condition follows EEI standards.

Projector Dimensions

405 mm (W) x 305 mm (D) x 144 mm (H)

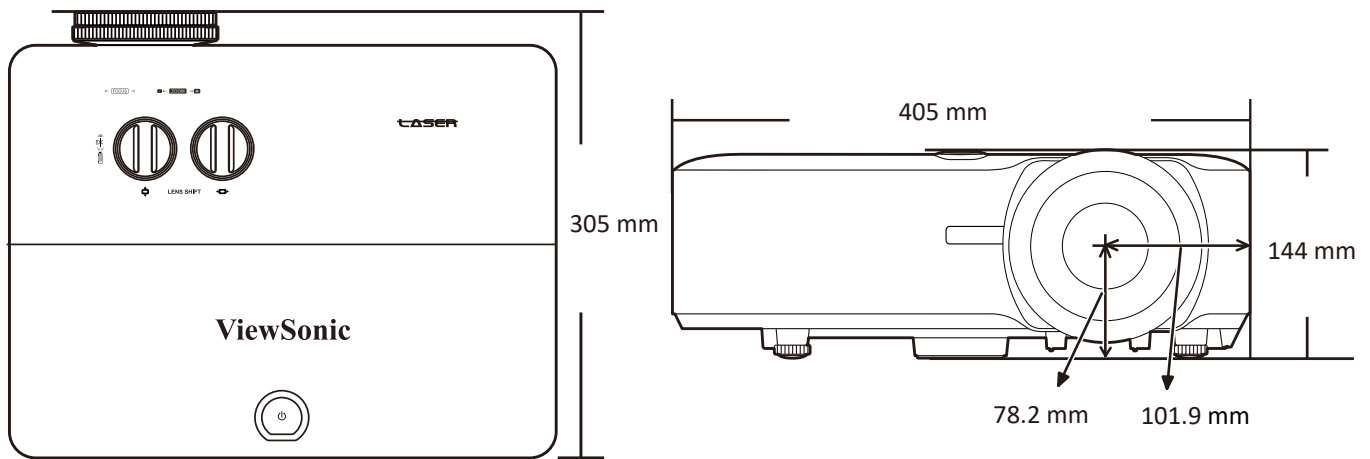

Timing Chart

Analog RGB

| Resolution | Mode | Refresh rate (Hz) | H-frequency (kHz) | Clock (MHz) | 3D Sync | | |
|------------|----------------------------|-------------------|-------------------|-------------|------------------|------------|--------------|
| | | | | | Frame Sequential | Top-Bottom | Side-by-Side |
| 720 x 400 | 720 x 400_70 | 70.087 | 31.469 | 28.3221 | | | |
| 640 x 480 | VGA_60 | 59.94 | 31.469 | 25.175 | ⊙ | ⊙ | ⊙ |
| | VGA_72 | 72.809 | 37.861 | 31.5 | | | |
| | VGA_75 | 75 | 37.5 | 31.5 | | | |
| | VGA_85 | 85.008 | 43.269 | 36 | | | |
| 800 x 600 | SVGA_60 | 60.317 | 37.879 | 40 | ⊙ | ⊙ | ⊙ |
| | SVGA_72 | 72.188 | 48.077 | 50 | | | |
| | SVGA_75 | 75 | 46.875 | 49.5 | | | |
| | SVGA_85 | 85.061 | 53.674 | 56.25 | | | |
| | SVGA_120 (Reduce Blanking) | 119.854 | 77.425 | 83 | ⊙ | | |
| 1024 x 768 | XGA_60 | 60.004 | 48.363 | 65 | ⊙ | ⊙ | ⊙ |
| | XGA_70 | 70.069 | 56.476 | 75 | | | |
| | XGA_75 | 75.029 | 60.023 | 78.75 | | | |
| | XGA_85 | 84.997 | 68.667 | 94.5 | | | |
| | XGA_120 (Reduce Blanking) | 119.989 | 97.551 | 115.5 | ⊙ | | |
| 1152 x 864 | 1152 x 864_75 | 75 | 67.5 | 108 | | | |
| 1024 x 576 | NB Timing | 60 | 35.82 | 46.966 | | | |
| 1024 x 600 | NB Timing | 64.995 | 41.467 | 51.419 | | | |
| 1280 x 720 | 1280 x 720_60 | 60 | 45 | 74.25 | ⊙ | ⊙ | ⊙ |

| Resolution | Mode | Refresh rate (Hz) | H-frequency (kHz) | Clock (MHz) | 3D Sync | | |
|--------------------|----------------------------------|-------------------|-------------------|-------------|------------------|------------|--------------|
| | | | | | Frame Sequential | Top-Bottom | Side-by-Side |
| 1280 x 768 | 1280 x 768_60 | 59.87 | 47.776 | 79.5 | ⊙ | ⊙ | ⊙ |
| 1280 x 800 | WXGA_60 | 59.81 | 49.702 | 83.5 | ⊙ | ⊙ | ⊙ |
| | WXGA_75 | 74.934 | 62.795 | 106.5 | | | |
| | WXGA_85 | 84.88 | 71.554 | 122.5 | | | |
| | WXGA_120 (Reduce Blanking) | 119.909 | 101.563 | 146.25 | ⊙ | | |
| 1280 x 1024 | SXGA_60 | 60.02 | 63.981 | 108 | | ⊙ | ⊙ |
| | SXGA_75 | 75.025 | 79.976 | 135 | | | |
| | SXGA_85 | 85.024 | 91.146 | 157.5 | | | |
| 1280 x 960 | 1280 x 960_60 | 60 | 60 | 108 | | ⊙ | ⊙ |
| | 1280 x 960_85 | 85.002 | 85.938 | 148.5 | | | |
| 1360 x 768 | 1360 x 768_60 | 60.015 | 47.712 | 85.5 | | ⊙ | ⊙ |
| 1440 x 900 | WXGA+_60 | 59.887 | 55.935 | 106.5 | | ⊙ | ⊙ |
| 1400 x 1050 | SXGA+_60 | 59.978 | 65.317 | 121.75 | | ⊙ | ⊙ |
| 1600 x 1200 | UXGA | 60 | 75 | 162 | | ⊙ | ⊙ |
| 1680 x 1050 | 1680x1050_60 | 59.954 | 65.29 | 146.25 | | ⊙ | ⊙ |
| 640 x 480@67Hz | MAC13 | 66.667 | 35 | 30.24 | | | |
| 832 x 624@75Hz | MAC16 | 74.546 | 49.722 | 57.28 | | | |
| 1024 x 768@75Hz | MAC19 | 74.93 | 60.241 | 80 | | | |
| 1152 x 870@75Hz | MAC21 | 75.06 | 68.68 | 100 | | | |
| 1920 x 1080 (VESA) | 1920 x 1080_60 | 60 | 67.5 | 148.5 | | | |
| 1920 x 1200 | 1920 x 1200_60 (Reduce Blanking) | 59.950 | 74.038 | 154.000 | | ⊙ | ⊙ |

HDMI (PC)

| Resolution | Mode | Refresh rate (Hz) | H-frequency (kHz) | Clock (MHz) | 3D Sync | | |
|-------------|----------------------------|-------------------|-------------------|-------------|------------------|------------|--------------|
| | | | | | Frame Sequential | Top-Bottom | Side-by-Side |
| 640 x 480 | VGA_60 | 59.94 | 31.469 | 25.175 | ⊙ | ⊙ | ⊙ |
| | VGA_72 | 72.809 | 37.861 | 31.5 | | | |
| | VGA_75 | 75 | 37.5 | 31.5 | | | |
| | VGA_85 | 85.008 | 43.269 | 36 | | | |
| 720 x 400 | 720 x 400_70 | 70.087 | 31.469 | 28.3221 | | | |
| 800 x 600 | SVGA_60 | 60.317 | 37.879 | 40 | ⊙ | ⊙ | ⊙ |
| | SVGA_72 | 72.188 | 48.077 | 50 | | | |
| | SVGA_75 | 75 | 46.875 | 49.5 | | | |
| | SVGA_85 | 85.061 | 53.674 | 56.25 | | | |
| | SVGA_120 (Reduce Blanking) | 119.854 | 77.425 | 83 | ⊙ | | |
| 1024 x 768 | XGA_60 | 60.004 | 48.363 | 65 | ⊙ | ⊙ | ⊙ |
| | XGA_70 | 70.069 | 56.476 | 75 | | | |
| | XGA_75 | 75.029 | 60.023 | 78.75 | | | |
| | XGA_85 | 84.997 | 68.667 | 94.5 | | | |
| | XGA_120 (Reduce Blanking) | 119.989 | 97.551 | 115.5 | ⊙ | | |
| 1152 x 864 | 1152 x 864_75 | 75 | 67.5 | 108 | | | |
| 1024 x 576 | NB Timing | 60 | 35.82 | 46.966 | | | |
| 1024 x 600 | NB Timing | 64.995 | 41.467 | 51.419 | | | |
| 1280 x 720 | 1280 x 720_60 | 60 | 45 | 74.25 | ⊙ | ⊙ | ⊙ |
| 1280 x 768 | 1280 x 768_60 | 59.87 | 47.776 | 79.5 | ⊙ | ⊙ | ⊙ |
| 1280 x 800 | WXGA_60 | 59.81 | 49.702 | 83.5 | ⊙ | ⊙ | ⊙ |
| | WXGA_75 | 74.934 | 62.795 | 106.5 | | | |
| | WXGA_85 | 84.88 | 71.554 | 122.5 | | | |
| | WXGA_120 (Reduce Blanking) | 119.909 | 101.563 | 146.25 | ⊙ | | |
| 1280 x 1024 | SXGA_60 | 60.02 | 63.981 | 108 | | ⊙ | ⊙ |
| | SXGA_75 | 75.025 | 79.976 | 135 | | | |
| | SXGA_85 | 85.024 | 91.146 | 157.5 | | | |
| 1280 x 960 | 1280 x 960_60 | 60 | 60 | 108 | | ⊙ | ⊙ |
| | 1280 x 960_85 | 85.002 | 85.938 | 148.5 | | | |
| 1360 x 768 | 1360 x 768_60 | 60.015 | 47.712 | 85.5 | | ⊙ | ⊙ |
| 1440 x 900 | WXGA+_60 | 59.887 | 55.935 | 106.5 | | ⊙ | ⊙ |
| 1400 x 1050 | SXGA+_60 | 59.978 | 65.317 | 121.75 | | ⊙ | ⊙ |
| 1600 x 1200 | UXGA | 60 | 75 | 162 | | ⊙ | ⊙ |

| Resolution | Mode | Refresh rate (Hz) | H-frequency (kHz) | Clock (MHz) | 3D Sync | | |
|--------------------|-------------------------------------|-------------------|-------------------|-------------|------------------|------------|--------------|
| | | | | | Frame Sequential | Top-Bottom | Side-by-Side |
| 1680 x 1050 | 1680x1050_60 | 59.954 | 65.29 | 146.25 | | ⊙ | ⊙ |
| 640 x 480@67Hz | MAC13 | 66.667 | 35 | 30.24 | | | |
| 832 x 624@75Hz | MAC16 | 74.546 | 49.722 | 57.28 | | | |
| 1024 x 768@75Hz | MAC19 | 74.93 | 60.241 | 80 | | | |
| 1152 x 870@75Hz | MAC21 | 75.06 | 68.68 | 100 | | | |
| 1920 x 1080 (VESA) | 1920 x 1080_60 | 60 | 67.5 | 148.5 | | | |
| 1920 x 1200 | 1920 x 1200_60 (Reduce Blanking) | 59.950 | 74.038 | 154.000 | | ⊙ | ⊙ |
| 3840x2160 | 3840x2160_30 | 30 | 67.5 | 297 | | | |
| 3840x2160 | 3840x2160_60 | 60 | 135 | 594 | | | |

HDMI (Video)

| Video mode | Resolution | Horizontal frequency (KHz) | Vertical frequency (Hz) | Dot Clock frequency (MHz) | 3D Sync | | |
|------------|-----------------|----------------------------|-------------------------|---------------------------|------------------|------------|--------------|
| | | | | | Frame Sequential | Top-Bottom | Side-by-Side |
| 480i | 720(1440) x 480 | 15.73 | 59.94 | 27 | ⊙ | | |
| 480p | 720 x 480 | 31.47 | 59.94 | 27 | ⊙ | ⊙ | ⊙ |
| 576i | 720(1440) x 576 | 15.63 | 50 | 27 | ⊙ | | |
| 576p | 720 x 576 | 31.25 | 50 | 27 | ⊙ | ⊙ | ⊙ |
| 720/50p | 1280 x 720 | 37.5 | 50 | 74.25 | | ⊙ | |
| 720/60p | 1280 x 720 | 45 | 60 | 74.25 | | ⊙ | |
| 1080/50i | 1920 x 1080 | 28.13 | 50 | 74.25 | | | ⊙ |
| 1080/60i | 1920 x 1080 | 33.75 | 60 | 74.25 | | | ⊙ |
| 1080/24P | 1920 x 1080 | 27 | 24 | 74.25 | | | |
| 1080/50P | 1920 x 1080 | 56.25 | 50 | 148.5 | | ⊙ | ⊙ |
| 1080/60P | 1920 x 1080 | 67.5 | 60 | 148.5 | | ⊙ | ⊙ |
| 2160/24P | 3840 x 2160 | 54 | 24 | 297 | | | |
| 2160/25P | 3840 x 2160 | 56.25 | 25 | 297 | | | |
| 2160/30P | 3840 x 2160 | 67.5 | 30 | 297 | | | |
| 2160/50P | 3840 x 2160 | 112.5 | 50 | 594 | | | |
| 2160/60P | 3840 x 2160 | 135 | 60 | 594 | | | |

Video/S-Video

| Video mode | Horizontal frequency (KHz) | Vertical frequency (Hz) | Sub-carrier Frequency (MHz) |
|------------|----------------------------|-------------------------|-----------------------------|
| NTSC | 15.73 | 60 | 3.58 |
| PAL | 15.63 | 50 | 4.43 |
| SECAM | 15.63 | 50 | 4.25 or 4.41 |
| PAL-M | 15.73 | 60 | 3.58 |
| PAL-N | 15.63 | 50 | 3.58 |
| PAL-60 | 15.73 | 60 | 4.43 |
| NTSC4.43 | 15.73 | 60 | 4.43 |

Component video

| Video mode | Resolution | Horizontal frequency (KHz) | Vertical frequency (Hz) | Clock (MHz) | 3D Sync |
|------------|-------------|----------------------------|-------------------------|-------------|------------------|
| | | | | | Frame Sequential |
| 480i | 720 x 480 | 15.73 | 59.94 | 13.5 | ⊙ |
| 480p | 720 x 480 | 31.47 | 59.94 | 27 | ⊙ |
| 576i | 720 x 576 | 15.63 | 50 | 13.5 | ⊙ |
| 576p | 720 x 576 | 31.25 | 50 | 27 | ⊙ |
| 720/50p | 1280 x 720 | 37.5 | 50 | 74.25 | |
| 720/60p | 1280 x 720 | 45 | 60 | 74.25 | |
| 1080/50i | 1920 x 1080 | 28.13 | 50 | 74.25 | |
| 1080/60i | 1920 x 1080 | 33.75 | 60 | 74.25 | |
| 1080/50P | 1920 x 1080 | 56.25 | 50 | 148.5 | |
| 1080/60P | 1920 x 1080 | 67.5 | 60 | 148.5 | |

HDBaseT

| Cable type | Cable range | Pixel rate | HDMI format supports | |
|---------------|-------------|------------|------------------------|--------------------|
| CAT 5E/CAT 6A | 100m | <=225MHz | 640 x 480p/60Hz 4:3 | 24bit 30bit 36 bit |
| | | | 720 x 480p/60Hz 4:3 | 24bit 30bit 36 bit |
| | | | 720 x 480p/60Hz 16:9 | 24bit 30bit 36 bit |
| | | | 720 x 576p/50Hz 4:3 | 24bit 30bit 36 bit |
| | | | 1280 x 720p/50Hz 16:9 | 24bit 30bit 36 bit |
| | | | 1280 x 720p/60Hz 16:9 | 24bit 30bit 36 bit |
| | | | 1440 x 480i/60Hz 4:3 | 24bit 30bit 36 bit |
| | | | 1440 x 576i/50Hz 4:3 | 24bit 30bit 36 bit |
| | | | 1920 x 1080i/50Hz 16:9 | 24bit 30bit 36 bit |
| | | | 1920 x 1080i/60Hz 16:9 | 24bit 30bit 36 bit |
| | | | 1920 x 1080p/50Hz 16:9 | 24bit 30bit 36 bit |
| | | | 1920 x 1080p/60Hz 16:9 | 24bit 30bit 36 bit |



Troubleshooting

Common Problems

This section describes some common problems that you may experience when using the projector.

| Problem | Possible Solutions |
|----------------------------------|---|
| The projector does not turn on | <ul style="list-style-type: none">• Ensure the power cord is properly attached to the projector and to the power outlet.• If the cooling process has not completed, please wait until it has finished then try to turn on the projector again.• If the above does not work, try another power outlet or another electrical device with the same power outlet. |
| There is no picture | <ul style="list-style-type: none">• Ensure the video source cable is connected properly, and that the video source is turned on.• If the input source is not selected automatically, select the correct source with the Source key on either the projector or the remote control. |
| The image is blurred | <ul style="list-style-type: none">• Adjusting the Focus Ring will help correctly focus the projection lens.• Ensure the projector and screen are aligned properly. If necessary, adjust the height of the projector as well as the projection angle and direction. |
| The remote control does not work | <ul style="list-style-type: none">• Ensure there are no obstacles between the remote control and projector; and that they are within 8 m (26 ft) of each other.• The batteries may be out of power, please check and replace if necessary. |

LED Indicators

| Light | | | Status and Description |
|---|---|---|--|
|  |  |  | |
| Power | | | |
| Green Flashing | Off | Off | Stand-by mode |
| Green | Off | Off | Powering up |
| Green | Off | Off | Normal operation |
| Green Flashing | Off | Off | Normal power-down cooling |
| Red | Off | Off | Downloading |
| Green | Green | Green | Burn in off |
| Light source | | | |
| Green Flashing | Off | Red | First light source-lit error cooling |
| Off | Off | Red | Light source error in normal operation |
| Green | Off | Red | Color wheel start has failed |
| Heating/Cooling | | | |
| Off | Red | Off | Fan 1 error (actual fan speed is outside the desired speed). |
| Off | Red | Red | Fan 2 error (actual fan speed is outside the desired speed). |
| Off | Red | Green | Fan 3 error (actual fan speed is outside the desired speed). |
| Off | Red | Orange | Fan 4 error (actual fan speed is outside the desired speed). |
| Red Flashing | Red | Off | Fan 5 error (actual fan speed is outside the desired speed). |
| Red Flashing | Red Flashing | Off | Fan 6 error (actual fan speed is outside the desired speed). |
| Red | Red | Red | Thermal sensor 1 open error (the remote diode has an open-circuit condition). |
| Red | Red | Green | Thermal sensor 2 open error (the remote diode has an open-circuit condition). |
| Green | Red | Red | Thermal sensor 1 short error (the remote diode has an open-circuit condition). |
| Off | Red | Green | Thermal sensor 2 short error (the remote diode has an open-circuit condition). |
| Orange | Red | Red | Temperature 1 error (over limited temperature). |
| Orange | Red | Green | Temperature 2 error (over limited temperature). |
| Off | Green | Red | Fan IC #1 I2C connection error. |

Maintenance

General Precautions

- Make sure the Projector is turned off and the power cable is unplugged from the power outlet.
- Never remove any parts from the Projector. Contact ViewSonic® or a reseller when any part of the Projector needs replacing.
- Never spray or pour any liquid directly onto the case.
- Handle the Projector with care, as a darker-colored projector, if scuffed, may show marks more clearly than a lighter-colored projector.

Cleaning the Lens

- Use a canister of compressed air to remove dust.
- If the lens is still not clean, use lens-cleaning paper or moisten a soft cloth with lens cleaner and gently wipe the surface.

CAUTION: Never rub the lens with abrasive materials.

Cleaning the Case

- Use a soft, lint-free, dry cloth to remove dirt or dust.
- If the case is still not clean, apply a small amount of non-ammonia, non-alcohol based, mild non-abrasive detergent onto a clean, soft, lint-free cloth, then wipe the surface.

CAUTION: Never use wax, alcohol, benzene, thinner, or other chemical detergents.

Storing the Projector

If you intend to store the Projector for an extended period of time:

- Ensure the temperature and humidity of the storage area are within the recommend range.
- Retract the adjuster foot completely.
- Remove the batteries from the Remote Control.
- Pack the Projector in its original packaging or equivalent.

Disclaimer

- ViewSonic® does not recommend the use of any ammonia or alcohol-based cleaners on the lens or case. Some chemical cleaners have been reported to damage the lens and/or case of the projector.
- ViewSonic® will not be liable for damage resulting from use of any ammonia or alcohol-based cleaners.

Light Source Information

This section will provide a better understanding of your projector's light source.

Light Source Hour

When the projector is being used, the duration (in hours) of light source usage is automatically calculated by the built-in timer.

To obtain the light source hour information:

1. Press **Menu** to open the OSD Menu and go to: **Advanced > Light Source Settings > Light Source Hours Information**.
2. Press **Enter** and the **Light Source Hours Information** page will appear.
3. Press **Exit** to leave the menu.

Extending Light Source Life

To prolong light source life, you can adjust the following settings in the OSD Menu.

Setting Light Source Mode

Setting the projector in **Eco**, **Dynamic Eco**, or **SuperEco+** mode reduces system noise, power consumption, and extends the light source's operational life.

| Light source Mode | Description |
|-------------------|---|
| Normal | Provides full light source brightness. |
| Eco | Reduces light source power consumption by 30% and lowers brightness, and decreases fan noise. |
| Dynamic Eco | Reduces light source power consumption by up to 60% depending on the content's brightness level. |
| Custom | Allows you to adjust the light source power to extend the light source life and decrease the fan noise. |

To set the Light Source Mode, open the OSD Menu and go to: **Advanced > Light Source Settings > Light Source Mode** and press ◀/▶ to select and press **Enter**.

Setting Auto Power Off

This allows the projector to turn off automatically after a set period of time once no input source is detected.

Open the OSD Menu and go to: **POWER MANAGEMENT > Smart Energy > Auto Power Off** and press ◀/▶ to disable or adjust the time.

> Regulatory and Service Information

Compliance Information

This section addresses all connected requirements and statements regarding regulations. Confirmed corresponding applications shall refer to nameplate labels and relevant markings on the unit.

FCC Compliance Statement

This device complies with part 15 of FCC Rules. Operation is subject to the following two conditions: (1) this device may not cause harmful interference, and (2) this device must accept any interference received, including interference that may cause undesired operation. This equipment has been tested and found to comply with the limits for a Class B digital device, pursuant to part 15 of the FCC Rules.

These limits are designed to provide reasonable protection against harmful interference in a residential installation. This equipment generates, uses, and can radiate radio frequency energy, and if not installed and used in accordance with the instructions, may cause harmful interference to radio communications. However, there is no guarantee that interference will not occur in a particular installation. If this equipment does cause harmful interference to radio or television reception, which can be determined by turning the equipment off and on, the user is encouraged to try to correct the interference by one or more of the following measures:

- Reorient or relocate the receiving antenna.
- Increase the separation between the equipment and receiver.
- Connect the equipment into an outlet on a circuit different from that to which the receiver is connected.
- Consult the dealer or an experienced radio/TV technician for help.

Warning: You are cautioned that changes or modifications not expressly approved by the party responsible for compliance could void your authority to operate the equipment.

Industry Canada Statement

FCC Radiation Exposure Statement

This equipment complies with FCC radiation exposure limits set forth for an uncontrolled environment. End users must follow the specific operating instructions for satisfying RF exposure compliance.

This transmitter must not be co-located or operating in conjunction with any other antenna or transmitter. This equipment should be installed and operated with a minimum distance of 20 centimeters between the radiator and your body.

The users manual or instruction manual for an intentional or unintentional radiator shall caution the user that changes or modifications not expressly approved by the party responsible for compliance could void the user's authority to operate the equipment.

IC Warning Statement

This device complies with Industry Canada license- exempt RSS standard(s). Operation is subject to the following two conditions: (1) this device may not cause interference, and (2) this device must accept any interference, including interference that may cause undesired operation of the device.

Le présent appareil est conforme aux CNR d'Industrie Canada applicables aux appareils radio exempts de licence. L'exploitation est autorisée aux deux conditions suivantes : (1) l'appareil ne doit pas produire de brouillage, et (2) l'utilisateur de l'appareil doit accepter tout brouillage radioélectrique subi, même si le brouillage est susceptible d'en compromettre le fonctionnement.

Country Code Statement

For product available in the USA/Canada market, only channel 1~11 can be operated. Selection of other channels is not possible.

Pour les produits disponibles aux États-Unis/Canada du marché, seul le canal 1 à 11 peuvent être exploités. Sélection d'autres canaux n'est pas possible.

IC Radiation Exposure Statement

This equipment complied with IC RSS-102 radiation exposure limits set forth for an uncontrolled environment. This equipment should be installed and operated with minimum distance 20cm between the radiator & your body. The device for the band 5150-5825 MHz is only for indoor usage to reduce potential for harmful interference to co-channel mobile satellite systems.

Cet équipement est conforme aux limites d'exposition aux rayonnements IC établies pour un environnement non contrôlé. Cet équipement doit être installé et utilise avec un minimum de 20cm de distance entre la source de rayonnement et votre corps. les dispositifs fonctionnant dans la bande 5150-5825 MHz sont réservés uniquement pour une utilisation à l'intérieur afin de réduire les risques de brouillage

CE Conformity for European Countries

CE The device complies with the EMC Directive 2014/30/EU, Low Voltage Directive 2014/35/EU, Ecodesign Directive 2009/125/EC and Radio Equipment Directive 2014/53/EU.

The following information is only for EU-member states:

The mark shown to the right is in compliance with the Waste Electrical and Electronic Equipment Directive 2012/19/EU (WEEE). The mark indicates the requirement NOT to dispose of the equipment as unsorted municipal waste, but use the return and collection systems according to local law.



Declaration of RoHS2 Compliance

This product has been designed and manufactured in compliance with Directive 2011/65/EU of the European Parliament and the Council on restriction of the use of certain hazardous substances in electrical and electronic equipment (RoHS2 Directive) and is deemed to comply with the maximum concentration values issued by the European Technical Adaptation Committee (TAC) as shown below:

| Substance | Proposed Maximum Concentration | Actual Concentration |
|---|--------------------------------|----------------------|
| Lead (Pb) | 0.1% | < 0.1% |
| Mercury (Hg) | 0.1% | < 0.1% |
| Cadmium (Cd) | 0.01% | < 0.01% |
| Hexavalent Chromium (Cr6 ⁺) | 0.1% | < 0.1% |
| Polybrominated biphenyls (PBB) | 0.1% | < 0.1% |
| Polybrominated diphenyl ethers (PBDE) | 0.1% | < 0.1% |
| Bis(2-Ethylhexyl) phthalate (DEHP) | 0.1% | < 0.1% |
| Benzyl butyl phthalate (BBP) | 0.1% | < 0.1% |
| Dibutyl phthalate (DBP) | 0.1% | < 0.1% |
| Diisobutyl phthalate (DIBP) | 0.1% | < 0.1% |

Certain components of products as stated above are exempted under the Annex III of the RoHS2 Directives as noted below. Examples of exempted components are:

- Mercury in cold cathode fluorescent lamps and external electrode fluorescent lamps (CCFL and EEFL) for special purposes not exceeding (per lamp):
 - » Short length (500 mm): maximum 3.5 mg per lamp.
 - » Medium length (> 500 mm and 1,500 mm): maximum 5 mg per lamp.
 - » Long length (> 1,500 mm): maximum 13 mg per lamp.
- Lead in glass of cathode ray tubes.
- Lead in glass of fluorescent tubes not exceeding 0.2% by weight.
- Lead as an alloying element in aluminum containing up to 0.4% lead by weight.
- Copper alloy containing up to 4% lead by weight.
- Lead in high melting temperature type solders (i.e. lead-based alloys containing 85% by weight or more lead).
- Electrical and electronic components containing lead in a glass or ceramic other than dielectric ceramic in capacitors, e.g. piezoelectronic devices, or in a glass or ceramic matrix compound.

Indian Restriction of Hazardous Substances

Restriction on Hazardous Substances statement (India). This product complies with the “India E-waste Rule 2011” and prohibits use of lead, mercury, hexavalent chromium, polybrominated biphenyls or polybrominated diphenyl ethers in concentrations exceeding 0.1 weight % and 0.01 weight % for cadmium, except for the exemptions set in Schedule 2 of the Rule.

Product Disposal at End of Product Life

ViewSonic® respects the environment and is committed to working and living green. Thank you for being part of Smarter, Greener Computing. Please visit the ViewSonic® website to learn more.

USA & Canada:

<http://www.viewsonic.com/company/green/recycle-program/>

Europe:

<http://www.viewsoniceurope.com/eu/support/call-desk/>

Taiwan:

<https://recycle.epa.gov.tw/>

Copyright Information

Copyright© ViewSonic® Corporation, 2021 All rights reserved.

Macintosh and Power Macintosh are registered trademarks of Apple Inc.

Microsoft, Windows, and the Windows logo are registered trademarks of Microsoft Corporation in the United States and other countries.

ViewSonic®, the three birds logo, OnView, ViewMatch, and ViewMeter are registered trademarks of ViewSonic® Corporation.

VESA is a registered trademark of the Video Electronics Standards Association. DPMS, DisplayPort, and DDC are trademarks of VESA.

ENERGY STAR® is a registered trademark of the U.S. Environmental Protection Agency (EPA).

As an ENERGY STAR® partner, ViewSonic® Corporation has determined that this product meets the ENERGY STAR® guidelines for energy efficiency.

Disclaimer: ViewSonic® Corporation shall not be liable for technical or editorial errors or omissions contained herein; nor for incidental or consequential damages resulting from furnishing this material, or the performance or use of this product.

In the interest of continuing product improvement, ViewSonic® Corporation reserves the right to change product specifications without notice. Information in this document may change without notice.

No part of this document may be copied, reproduced, or transmitted by any means, for any purpose without prior written permission from ViewSonic® Corporation.

Customer Service

For technical support or product service, see the table below or contact your reseller.

NOTE: You will need the product's serial number.

| Country/ Region | Website | Country/ Region | Website |
|----------------------------------|--|--------------------------|--|
| Asia Pacific & Africa | | | |
| Australia | www.viewsonic.com/au/ | Bangladesh | www.viewsonic.com/bd/ |
| 中国 (China) | www.viewsonic.com.cn | 香港 (繁體中文) | www.viewsonic.com/hk/ |
| Hong Kong (English) | www.viewsonic.com/hk-en/ | India | www.viewsonic.com/in/ |
| Indonesia | www.viewsonic.com/id/ | Israel | www.viewsonic.com/il/ |
| 日本 (Japan) | www.viewsonic.com/jp/ | Korea | www.viewsonic.com/kr/ |
| Malaysia | www.viewsonic.com/my/ | Middle East | www.viewsonic.com/me/ |
| Myanmar | www.viewsonic.com/mm/ | Nepal | www.viewsonic.com/np/ |
| New Zealand | www.viewsonic.com/nz/ | Pakistan | www.viewsonic.com/pk/ |
| Philippines | www.viewsonic.com/ph/ | Singapore | www.viewsonic.com/sg/ |
| 臺灣 (Taiwan) | www.viewsonic.com/tw/ | ประเทศไทย | www.viewsonic.com/th/ |
| Việt Nam | www.viewsonic.com/vn/ | South Africa & Mauritius | www.viewsonic.com/za/ |
| Americas | | | |
| United States | www.viewsonic.com/us | Canada | www.viewsonic.com/us |
| Latin America | www.viewsonic.com/la | | |
| Europe | | | |
| Europe | www.viewsonic.com/eu/ | France | www.viewsonic.com/fr/ |
| Deutschland | www.viewsonic.com/de/ | Қазақстан | www.viewsonic.com/kz/ |
| Россия | www.viewsonic.com/ru/ | España | www.viewsonic.com/es/ |
| Türkiye | www.viewsonic.com/tr/ | Україна | www.viewsonic.com/ua/ |
| United Kingdom | www.viewsonic.com/uk/ | | |

Limited Warranty

ViewSonic® Projector

What the warranty covers:

ViewSonic® warrants its products to be free from defects in material and workmanship, under normal use, during the warranty period. If a product proves to be defective in material or workmanship during the warranty period, ViewSonic® will, at its sole option, repair or replace the product with a like product. Replacement product or parts may include remanufactured or refurbished parts or components.

Limited Three (3) year General Warranty:

Subject to the more limited one (1) year warranty set out below, North and South America: Three (3) years warranty for all parts excluding the lamp, three (3) years for labor, and one (1) year for the original lamp from the date of the first consumer purchase.

Other regions or countries: Please check with your local dealer or local ViewSonic® office for the warranty information.

Limited One (1) year Heavy Usage Warranty:

Under heavy usage settings, where a projector's use includes more than fourteen (14) hours average daily usage, North and South America: One (1) year warranty for all parts excluding the lamp, one (1) year for labor, and ninety (90) days for the original lamp from the date of the first consumer purchase; Europe: One (1) year warranty for all parts excluding the lamp, one (1) year for labor, and ninety (90) days for the original lamp from the date of the first consumer purchase. Other regions or countries: Please check with your local dealer or local ViewSonic® office for the warranty information. Lamp warranty subject to terms and conditions, verification and approval. Applies to manufacturer's installed lamp only. All accessory lamps purchased separately are warranted for 90 days.

Who the warranty protects:

This warranty is valid only for the first consumer purchaser.

What the warranty does not cover:

1. Any product on which the serial number has been defaced, modified, or removed.
2. Damage, deterioration, or malfunction resulting from:

- » Accident, misuse, neglect, fire, water, lightning, or other acts of nature, unauthorized product modification, or failure to follow instructions supplied with the product.
- » Operation outside of product specifications.
- » Operation of the product for other than the normal intended use or not under normal conditions.
- » Repair or attempted repair by anyone not authorized by ViewSonic®.
- » Any damage of the product due to shipment.
- » Removal or installation of the product.
- » Causes external to the product, such as electric power fluctuations or failure.
- » Use of supplies or parts not meeting Viewsonic's specifications.
- » Normal wear and tear.
- » Any other cause which does not relate to a product defect.

3. Removal, installation, and set-up service charges.

How to get service:

1. For information about receiving service under warranty, contact ViewSonic® Customer Support (Please refer to the "Customer Support" page). You will need to provide your product's serial number.
2. To obtain warranted service, you will be required to provide: (a) the original dated sales slip, (b) your name, (c) your address, (d) a description of the problem, and (e) the serial number of the product.
3. Take or ship the product, freight prepaid, in the original container to an authorized ViewSonic® service center or ViewSonic®.
4. For additional information or the name of the nearest ViewSonic® service center, contact ViewSonic®.

Limitation of implied warranties:

There are no warranties, express or implied, which extend beyond the description contained herein including the implied warranty of merchantability and fitness for a particular purpose.

Exclusion of damages:

ViewSonic's liability is limited to the cost of repair or replacement of the product. ViewSonic® shall not be liable for:

1. Damage to other property caused by any defects in the product, damages based upon inconvenience, loss of use of the product, loss of time, loss of profits, loss of business opportunity, loss of goodwill, interference with business relationships, or other commercial loss, even if advised of the possibility of such damages.
2. Any other damages, whether incidental, consequential or otherwise.
3. Any claim against the customer by any other party.

Effect of state law:

This warranty gives you specific legal rights, and you may also have other rights which vary from local authority. Some local governments do not allow limitations on implied warranties and/or do not allow the exclusion of incidental or consequential damages, so the above limitations and exclusions may not apply to you.

Sales outside the U.S.A. and Canada:

For warranty information and service on ViewSonic® products sold outside of the U.S.A. and Canada, contact ViewSonic® or your local ViewSonic® dealer.

The warranty period for this product in mainland China (Hong Kong, Macao, and Taiwan Excluded) is subject to the terms and conditions of the Maintenance Guarantee Card.

For users in Europe and Russia, full details of warranty provided can be found at: <http://www.viewsonic.com/eu/> under "Support/Warranty Information".

Mexico Limited Warranty

ViewSonic® Projector

What the warranty covers:

ViewSonic® warrants its products to be free from defects in material and workmanship, under normal use, during the warranty period. If a product proves to be defective in material or workmanship during the warranty period, ViewSonic® will, at its sole option, repair or replace the product with a like product. Replacement product or parts may include remanufactured or refurbished parts or components & accessories.

How long the warranty is effective:

3 years for all parts excluding the lamp, 3 years for labor, 1 year for the original lamp from the date of the first consumer purchase.

Lamp warranty subject to terms and conditions, verification and approval. Applies to manufacturer's installed lamp only.

All accessory lamps purchased separately are warranted for 90 days.

Who the warranty protects:

This warranty is valid only for the first consumer purchaser.

What the warranty excludes and does not cover:

1. Any product on which the serial number has been defaced, modified or removed.
2. Damage, deterioration, or malfunction resulting from:
 - » Accident, misuse, neglect, fire, water, lightning, or other acts of nature, unauthorized product modification, unauthorized attempted repair, or failure to follow instructions supplied with the product.
 - » Any damage of the product due to shipment.
 - » Causes external to the product, such as electrical power fluctuations or failure.
 - » Use of supplies or parts not meeting ViewSonic®'s specifications.
 - » Normal wear and tear.
 - » Any other cause which does not relate to a product defect.
3. Any product exhibiting a condition commonly known as "image burn-in" which results when a static image is displayed on the product for an extended period of time.
4. Removal, installation, insurance, and set-up service charges.

How to get service:

For information about receiving service under warranty, contact ViewSonic® Customer Support (Please refer to the attached “Customer Service” page). You will need to provide your product’s serial number, so please record the product information in the space provided below on your purchase for your future use. Please retain your receipt of proof of purchase to support your warranty claim.

For Your Records

Product Name: _____ Model Number: _____

Document Number: _____ Serial Number: _____

Purchase Date: _____ Extended Warranty Purchase? _____ (Y/N)

If so, what date does warranty expire? _____

1. To obtain warranty service, you will be required to provide (a) the original dated sales slip, (b) your name, (c) your address, (d) a description of the problem, and (e) the serial number of the product.
2. Take or ship the product, in the original container packaging, to an authorized ViewSonic® service center.
3. Round trip transportation costs for in-warranty products will be paid by ViewSonic®.

Limitation of implied warranties:

There are no warranties, express or implied, which extend beyond the description contained herein including the implied warranty of merchantability and fitness for a particular purpose.

Exclusion of damages:

ViewSonic®’s liability is limited to the cost of repair or replacement of the product. ViewSonic® shall not be liable for:

1. Damage to other property caused by any defects in the product, damages based upon inconvenience, loss of use of the product, loss of time, loss of profits, loss of business opportunity, loss of goodwill, interference with business relationships, or other commercial loss, even if advised of the possibility of such damages.
2. Any other damages, whether incidental, consequential or otherwise.
3. Any claim against the customer by any other party.
4. Repair or attempted repair by anyone not authorized by ViewSonic®.

| | |
|---|---|
| Contact Information for Sales & Authorized Service (Centro Autorizado de Servicio) within Mexico: | |
| Name, address, of manufacturer and importers: México, Av. de la Palma #8 Piso 2 Despacho 203, Corporativo Interpalmas, Col. San Fernando Huixquilucan, Estado de México Tel: (55) 3605-1099 http://www.viewsonic.com/la/soporte/index.htm | |
| NÚMERO GRATIS DE ASISTENCIA TÉCNICA PARA TODO MÉXICO: 001.866.823.2004 | |
| Hermosillo: Distribuciones y Servicios Computacionales SA de CV. Calle Juárez 284 local 2 Col. Bugambilias C.P: 83140 Tel: 01-66-22-14-9005 E-Mail: disc2@hmo.megared.net.mx | Villahermosa: Compumantenimientos Garantizados, S.A. de C.V. AV. GREGORIO MENDEZ #1504 COL, FLORIDA C.P. 86040 Tel: 01 (993) 3 52 00 47 / 3522074 / 3 52 20 09 E-Mail: compumantenimientos@prodigy.net.mx |
| Puebla, Pue. (Matriz): RENTA Y DATOS, S.A. DE C.V. Domicilio: 29 SUR 721 COL. LA PAZ 72160 PUEBLA, PUE. Tel: 01(52).222.891.55.77 CON 10 LINEAS E-Mail: datos@puebla.megared.net.mx | Veracruz, Ver.: CONEXION Y DESARROLLO, S.A DE C.V. Av. Americas # 419 ENTRE PINZÓN Y ALVARADO Fracc. Reforma C.P. 91919 Tel: 01-22-91-00-31-67 E-Mail: gacosta@qplus.com.mx |
| Chihuahua: Soluciones Globales en Computación C. Magisterio # 3321 Col. Magisterial Chihuahua, Chih. Tel: 4136954 E-Mail: Cefeo@soluglobales.com | Cuernavaca: Compusupport de Cuernavaca SA de CV Francisco Leyva # 178 Col. Miguel Hidalgo C.P. 62040, Cuernavaca Morelos Tel: 01 777 3180579 / 01 777 3124014 E-Mail: aquevedo@compusupportcva.com |
| Distrito Federal: QPLUS, S.A. de C.V. Av. Coyoacán 931 Col. Del Valle 03100, México, D.F. Tel: 01(52)55-50-00-27-35 E-Mail : gacosta@qplus.com.mx | Guadalajara, Jal.: SERVICRECE, S.A. de C.V. Av. Niños Héroes # 2281 Col. Arcos Sur, Sector Juárez 44170, Guadalajara, Jalisco Tel: 01(52)33-36-15-15-43 E-Mail: mmiranda@servicrece.com |
| Guerrero Acapulco: GS Computación (Grupo Sesicomp) Progreso #6-A, Colo Centro 39300 Acapulco, Guerrero Tel: 744-48-32627 | Monterrey: Global Product Services Mar Caribe # 1987, Esquina con Golfo Pérsico Fracc. Bernardo Reyes, CP 64280 Monterrey N.L. México Tel: 8129-5103 E-Mail: aydeem@gps1.com.mx |
| MERIDA: ELECTROSER Av Reforma No. 403Gx39 y 41 Mérida, Yucatán, México CP97000 Tel: (52) 999-925-1916 E-Mail: rrrb@sureste.com | Oaxaca, Oax.: CENTRO DE DISTRIBUCION Y SERVICIO, S.A. de C.V. Murguía # 708 P.A., Col. Centro, 68000, Oaxaca Tel: 01(52)95-15-15-22-22 Fax: 01(52)95-15-13-67-00 E-Mail: gpotai2001@hotmail.com |
| Tijuana: STD Av Ferrocarril Sonora #3780 L-C Col 20 de Noviembre Tijuana, Mexico | FOR USA SUPPORT: ViewSonic® Corporation 381 Brea Canyon Road, Walnut, CA. 91789 USA Tel: 800-688-6688 E-Mail: http://www.viewsonic.com |



ViewSonic®
See the difference®