

# ▼ Contents

<b>Safety summary</b>	iii
<b>Introduction</b>	1
Unpacking the projector	2
Compatibility	4
Cables and adapters	5
Usage guidelines	5
If you need assistance	6
<b>Setting up the LitePro 580</b>	7
Getting started	7
Positioning the projector	8
Connections to the projector	8
Connecting a computer	9
Connecting video equipment	14
Connecting the remote control by cable	17
Powering up and adjusting the LitePro 580	18
Turning off the LitePro	20
<b>Using the LitePro 580</b>	21
Basic functions	21
Display mode controls	23
Menu mode controls	24
Using the menus	25
Reference to menu functions	26
<b>Using LP Utilities</b>	33
Connecting your computer	33
Installing the LP Utilities software	34
LP-Link Utility	35
LP Remote Programmer Utility	43

<b>Maintenance</b>	47
Cleaning the lens	47
Cleaning the remote control	48
Cleaning the fan intake filter	49
Replacing the projection lamp	50
Replacing batteries in the remote control	52
Replacing the fuse	53
<b>Troubleshooting</b>	55
Before you call for assistance	55
Common problems and solutions	56
Monitor lights	59
<b>Appendix</b>	61
Compatibility and cabling	61
About broadcast video	61
About computer video	62
Specifications	63
Pin assignments	64
Order information	66
Laptop display activation chart	67
<b>Index</b>	71

## ▼ Safety summary

Please read these instructions before using your LitePro. Failure to comply with these instructions could result in fire, electrical shock, personal injury or damage to equipment.

These graphics are used throughout this manual to draw your attention to important information about the LitePro:



Additional useful details or tips



Steps to avoid damage to your equipment



Steps to avoid personal injury

### **Do not look into the lens!**

Be very careful not to look into the projection lens when the projector is turned on. The bright light may harm your eyes. Be especially careful to keep children from looking into the lens.

### **Power source**

Use only a three-wire grounding type power source. The power source should not exceed 250 volts rms between the supply conductors or between either conductor and the ground.

### **Power cord**

Use only the power cord that was shipped with the LitePro. Although other power cords might be similar in appearance, they have not been safety-tested with the LitePro. Do not use a power cord if it has become damaged or frayed. Contact your In Focus dealer or call In Focus if you need to replace your LitePro power cord.

### **Grounding**

The LitePro is grounded through the grounding conductor on the power cord. To avoid electric shock, plug the power cord into a properly wired receptacle. Do not defeat the purpose of the grounding-type plug.

### **Fuse**

For protection against the risk of fire, use only a fuse of the specified type. Refer to page 63 for more information about fuse specifications and to page 53 for instructions on replacing the fuse.

### **Lamp**

To avoid overheating and unacceptable image quality, replace the projection lamp with a lamp of the specified type. Refer to page 63 for lamp specifications and to page 50 for instructions on replacing the lamp.

### **Hot surfaces**

Allow the LitePro to cool at least 20 minutes before replacing a lamp. When you open the lamp housing, be very careful not to touch the hot surfaces inside.

### **Ventilation and overheating**

Openings in the LitePro case provide ventilation to protect it from overheating. Keep loose papers and other objects well away from the bottom, top and side grills. Do not place the LitePro on top of or close to a computer or other heat-producing equipment.

### **Liquid spills**

Do not set drinks on top of the LitePro. Spilled liquids can flow inside and damage the LitePro.

### **Do not disassemble**

All service must be performed by an authorized In Focus service center. The only user-serviceable part in the LitePro is the projection lamp, which you can replace by opening the lamp cover on the bottom of the projector. Do not open any other part of the LitePro.

## ▼ Introduction

The In Focus Systems LitePro 580 is a multimedia projector designed for portability, durability, and ease of use. It displays the brightest and clearest images generated by your computer and video equipment.

The LitePro 580 connects to most IBM-compatible and Macintosh computers. It also connects to VCRs, laser disc players, and camcorders using any of the worldwide video standards, including NTSC, PAL, and SECAM. Both computer and video sources have separate audio channels for better sound quality direct from the projector or from external speakers. The versatility of the LitePro 580 allows you to enhance your presentations by switching back and forth between computer-generated graphics and full-motion video with sound.

## Unpacking the projector

The projector comes with the parts shown below. Check to make sure all are included. If any parts are missing, contact your dealer immediately.

If you are experienced in setting up presentation systems, use the *Quick Start* card at the front of this manual. For complete details on connecting and operating the projector, refer to the appropriate chapters in this manual.

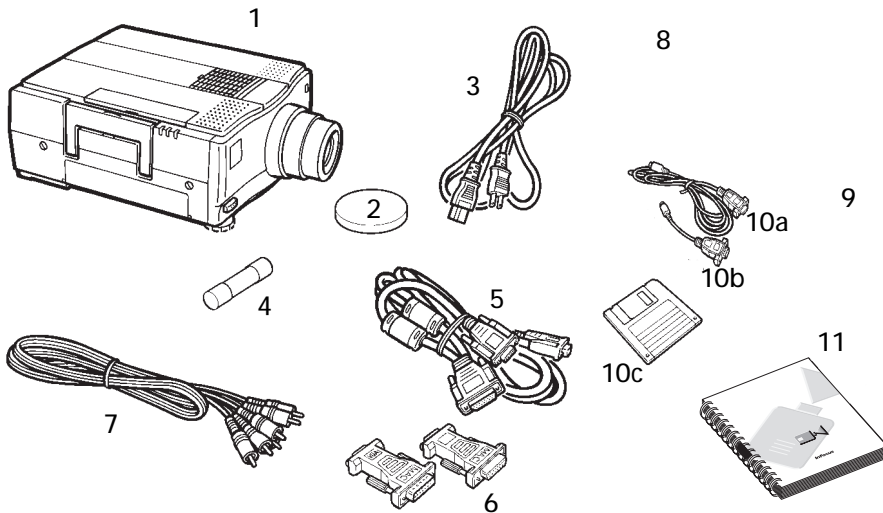

### Shipping Box Contents

- |                               |                                     |
|-------------------------------|-------------------------------------|
| 1. LitePro 580 LCD projector  | 8. Remote control                   |
| 2. Lens cover                 | 9. Batteries for the remote control |
| 3. Power cord                 | 10. LitePro Utilities kit           |
| 4. Fuse (6.3A, 250V, T.)      | a. LitePro Utilities serial cable   |
| 5. VGA (Y-shaped) cable       | b. Mac adapter for serial cable     |
| 6. Mac adapters for VGA cable | c. LitePro Utilities disks          |
| 7. Audio/video cable          | 11. LitePro 580 User's Guide        |



It is recommended that you do not reuse the LitePro's shipping carton to transport or ship the LitePro.

LitePro 580—Front and rear view

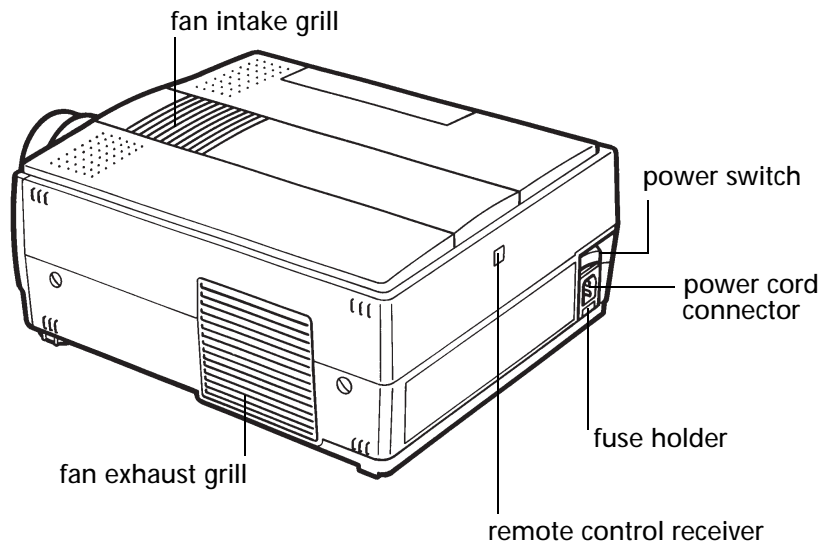
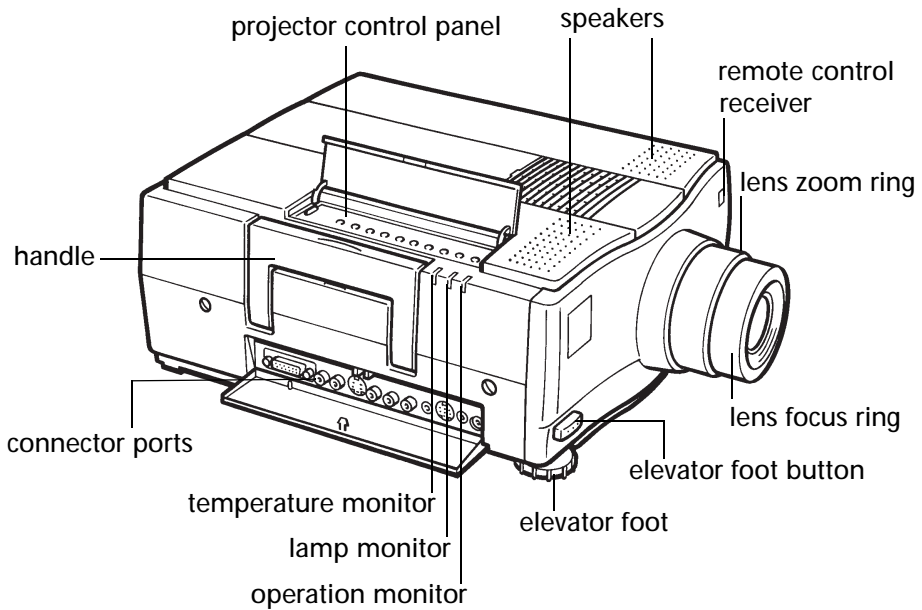

**LitePro 580—Bottom view**

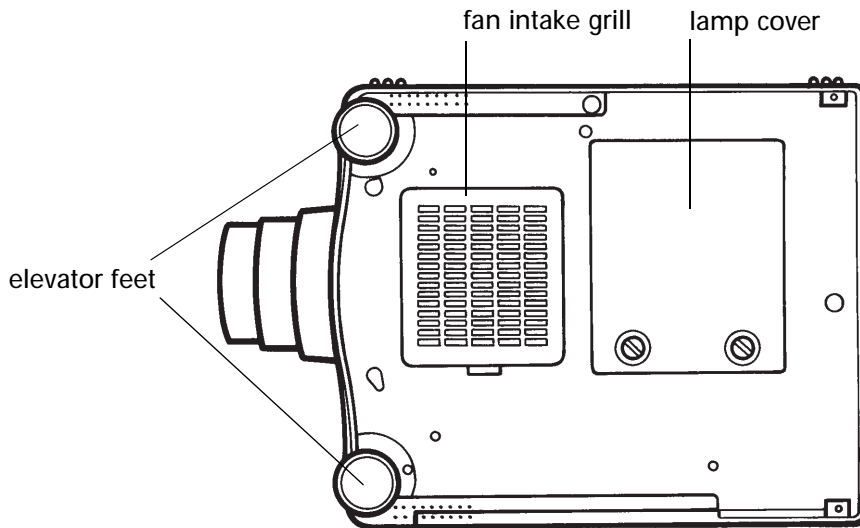

**Compatibility**

The LitePro 580 is compatible with a wide variety of computers and video devices, including:

- IBM-compatible desktop and laptop systems
- Macintosh systems (including LC, Performa, Quadra, PowerBook, and Power Mac units)
- Various VCRs, camcorders, laser disc and CD players



## Cables and adapters

The LitePro 580 comes with these cables and adapters:

- VGA cable, a Y-shaped cable that connects the LitePro to your computer and its monitor. Its ends are labeled “LCD,” “Monitor,” and “VGA.”
- Two Macintosh adapters for the VGA cable.
- Audio/video cable to connect the LitePro to your video equipment.
- LP Utilities serial cable to connect the LitePro to your computer.
- Macintosh adapter for the LP Utilities serial cable.
- Power cord.

## Usage guidelines

- The LitePro can become very warm during use. Make sure there is no flammable material such as paper or cloth under, on, or near the projector. Use extreme care when handling the projector. We recommend that you let the projector cool before lifting it.
- Do not block the ventilating grill on the left side of the projector. Restricting the air flow can cause it to overheat and shut down automatically.
- Do not place objects on or insert metallic objects in the projector.
- Avoid leaving the LitePro in direct sunlight or extreme cold for extended periods of time. If this happens, allow it to reach room temperature before use.
- Do not expose the LitePro to moisture or dust.
- Handle the LitePro as you would any product with glass components. Do not drop it.
- Transport the LitePro in the original shipping carton or vendor-approved hard or soft case.

## **If you need assistance**

The first place to look for help is in this manual. Check the chapter on “Troubleshooting” beginning on page 55.

If this manual does not answer your question, call your In Focus dealer. You can also call In Focus Technical Support directly at **1-800-294-6400**. Call between 6 a.m. and 5 p.m. PST, Monday through Friday. In Europe, call In Focus in The Netherlands at **31 (0) 2503-23200**.

Your LitePro is backed by a limited one-year warranty. For details, see the last page of this manual.

## ▼ Setting up the LitePro 580

This chapter describes how to position the LitePro for optimum viewing, how to connect computers and video equipment to the LitePro, and how to power up the projector.

### Getting started

1. Choose a location where you can dim the lighting.
  - To use the LitePro in a well-lit room, use a special high gain screen, which you can obtain from your In Focus dealer.
2. Place the LitePro on a flat surface.
3. Orient the LitePro so that its lens is at a right angle to the projection screen.
  - If you want to use the LitePro's Rear Project feature, set it up behind a translucent screen. See "Rear Proj" on page 28.
4. Remove the lens cover.
5. Plug the power cord into the LitePro, then plug it into your electrical outlet.

### Caution

Always use the power cord that was shipped with your LitePro. The LitePro accepts power from 110-120 VAC and 220-240 VAC, 50 or 60 Hz, three-wire type grounded sources. When you disconnect the LitePro, always remove the power cord from the electrical outlet first, then from the LitePro.

It is recommended that you connect a power strip between the LitePro and your electrical outlet to protect against a power surge.

## Positioning the projector

The distance from the LitePro 580 to the screen determines the size of the projected image. Use of the LitePro's X1.4 zoom lens also affects screen size. The table below indicates the size of the screen image when using the maximum or minimum zoom at various distances.

**Approximate size of image determined by distance of the projector to the screen**

Distance to screen in ft. (m)	4(1.2)	8 (2.5)	12 (4)	19 (6)	27 (8)	40 (12)
Diagonal image size in ft. (m) with maximum zoom	2.5 (1)	5 (1.5)	8 (2.5)	12 (3.5)	17 (5)	25 (7)
Diagonal image size in ft. (m) with minimum zoom	2 (.5)	3 (1)	6 (2)	8 (2.5)	12(3.5)	18 (5.5)

## Connections to the projector

The connection ports of the LitePro 580 are located on the right side of the projector, just below the handle. Push lightly on the panel labeled "Push" to reveal them. Cables from your computer or video source as well as cables to speakers, control devices, and low voltage powered equipment connect to the projector here.

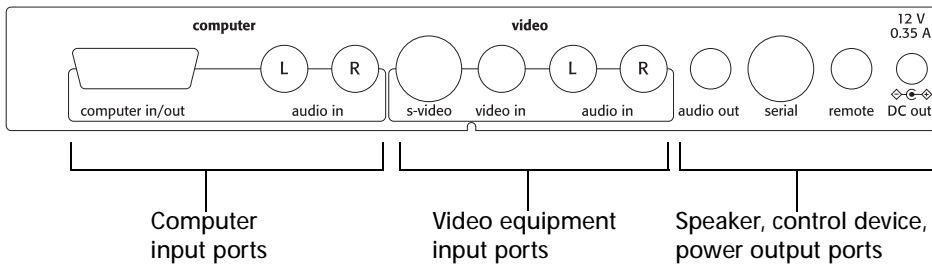

## **Connecting a computer**

Different computers require different connections. Connections to a Macintosh differ slightly from those to an IBM-compatible computer. Connections to a desktop unit differ from those to a laptop.

The LitePro 580 works with IBM, IBM-compatible, and Macintosh computers that have a video RGB output port.

To connect your computer, you need the Y-shaped VGA cable. If you have a Macintosh, you also need the Macintosh adapters. We recommend that you turn off your computer, monitor and projector whenever you connect or disconnect cables.

### Connecting an IBM-compatible desktop computer

1. Plug the LCD connector on the VGA cable into the projector's Computer port.
2. Unplug the monitor cable from the computer's graphic port.
3. Plug the monitor cable that you just removed into the MONITOR connector on the VGA cable.
4. Plug the VGA connector on the VGA cable into the computer's graphics port.
5. Tighten the thumb screws on all the connectors to ensure proper grounding.
6. Turn on the projector, monitor, and computer.

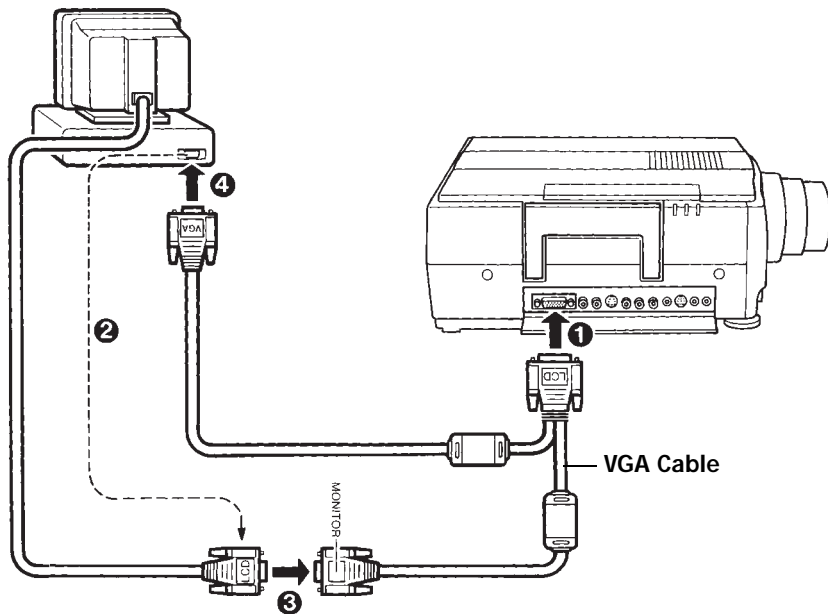

### Connecting a Macintosh desktop computer

1. Attach one Mac adapter to the VGA connector and one Mac adapter to the MONITOR connector of the VGA cable.
2. Plug the LCD connector on the VGA cable into the projector's Computer port.
3. Unplug the monitor cable from the computer's monitor port.
4. Plug the monitor cable that you just removed into the MONITOR connector (with the Mac adapter) on the VGA cable.
5. Plug the VGA connector (with the Mac adapter) on the VGA cable into the computer's graphics port.
6. Tighten the thumb screws on all the connectors to ensure proper grounding.
7. Turn on the projector, monitor, and computer.

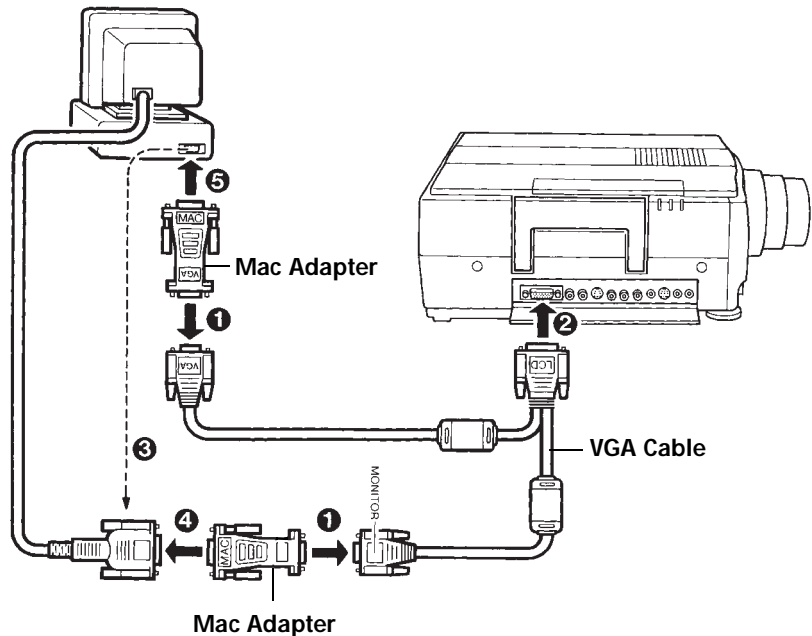

### Connecting an IBM-compatible laptop computer

1. Plug the LCD connector on the VGA cable into the projector's Computer port.
2. Plug the VGA connector on the VGA cable into the laptop's graphics port.
3. Tighten the thumb screws on the connectors to ensure proper grounding.
4. Turn on the projector and the laptop.
5. If necessary, activate the external display port. (Refer to the appendix of this manual for a list of activation commands.)

### Note

Many laptop computers do not automatically turn on their external video port when a secondary display device such as the LitePro is connected. Refer to your computer manual for the command that activates the external video port. Activation commands for some laptop computers are listed in the Appendix on page 67.

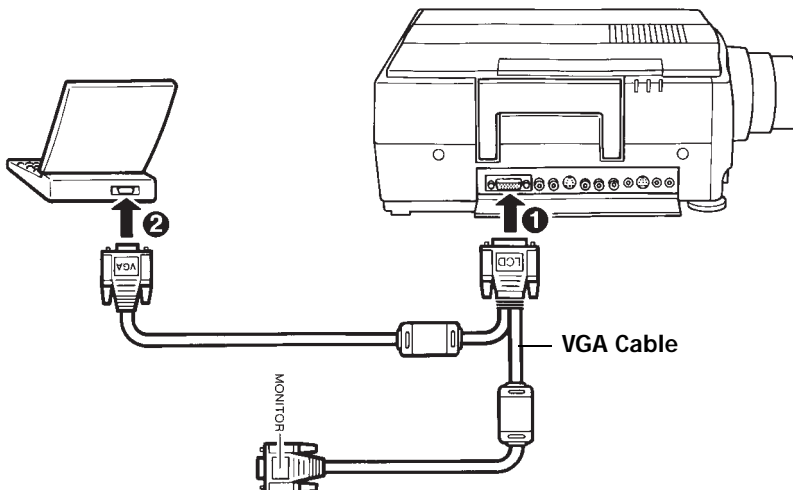



### Connecting a Macintosh PowerBook

1. Attach one Mac adapter to the VGA connector of the VGA cable.
2. Plug the LCD connector on the VGA cable into the projector's Computer port.
3. Plug the VGA connector (with the Mac adapter) on the VGA cable into the PowerBook's video port.
4. Tighten the thumb screws on all connectors.
5. Turn on the projector.
6. Turn on the PowerBook.
7. Enable video mirroring by opening the PowerBook Display Control panel and selecting "Mirroring."

#### **Note**

PowerBooks require the video-out cable, provided with each PowerBook, for external video. Use it to connect the PowerBook to the Mac adapter on the VGA cable.

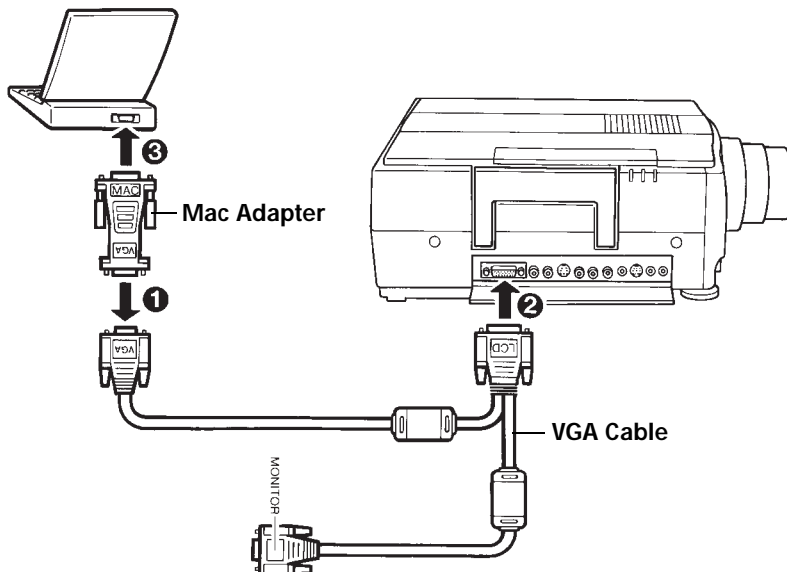

## Connecting video equipment

When connecting your VCR, camcorder, laser disc player, or other video source, use the A/V cable included with the projector and the LitePro 580's ports marked "Video."

The projector also accommodates higher quality S-Video signals. A round, four-pin connector S-Video cable is not included with the projector but is usually supplied with your video equipment. If both video inputs are connected, the S-video input has priority. Use S-Video connections when your video equipment is within a few feet of the projector. With the S-Video connection, the greater the distance between the video source and the projector, the more the signal will degrade.

The projector automatically detects the broadcast signal of the video input and accommodates the major broadcast systems: NTSC, PAL and SECAM. The projector also allows you to lock the projector to a specific broadcast system signal. (See "Video Mode" on page 27.) However, if the video signal does not match the locked broadcasting system, the projector won't reproduce the video image properly.

Connect your video equipment's audio output to the "Audio In" ports of either the Video source or the Computer source. If two audio inputs are connected at the same time, you can use the Audio menu to lock the projector to either of the two inputs. (See "Audio Source" on page 29.)

## Connecting audio/video equipment

1. Plug the yellow connector of the audio/video cable into the “Video Out” or “To Monitor” port on your video equipment. To use the S-Video connection, plug the S-Video cable into the “S-Video Out” port.

### **Caution**

Your video source may also have a “Video Out” port for a coaxial cable connection. Do not use this to connect to the LitePro 580.

2. Plug the white connector of the audio/video cable into the “Audio Out/L” port and the red connector into the “Audio Out/R” port on the video equipment.

### **Note**

To connect a monaural signal, use only the “Audio In/L” and “Audio Out/L” ports and the white connector on the A/V cable.

3. Plug the other yellow connector of the audio/video cable into the “Video In” port on the projector. If you are using S-Video, plug the other end of the S-Video cable into the projector’s “S-Video” port and unplug the yellow connector of the A/V cable.
4. Plug the other white connector of the audio/video cable into the “Audio In/L” port and the other red connector into the “Audio In/R” port on the projector.

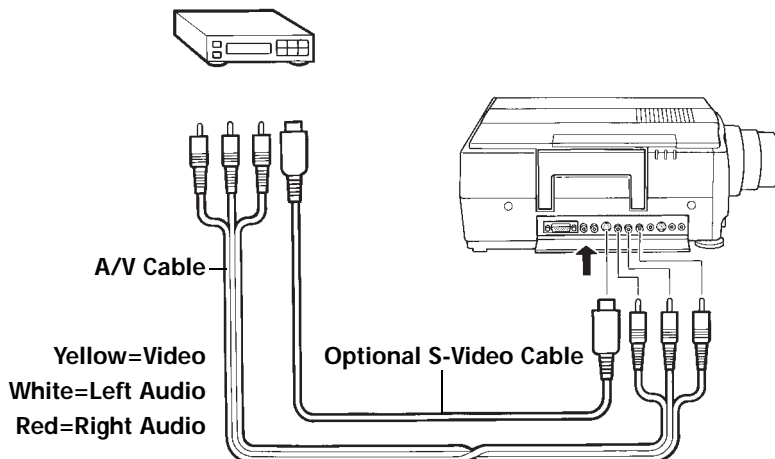

### Connecting an external sound system

You can use an external public address system or an external self-amplified speaker system for presentations in large halls or lecture rooms.

To connect the LitePro 580 to an external sound system, use an audio cable (3.5mm stereo mini plug), an optional accessory available from your In Focus dealer.

1. Plug one end of the audio cable into the “Audio Out” port on the projector.
2. Plug the other end of the cable into the corresponding “Audio In” jack on the external speaker(s).
3. Use the “Fade” feature on the Audio menu to adjust the audio output. (See “Fade” on page 29.)

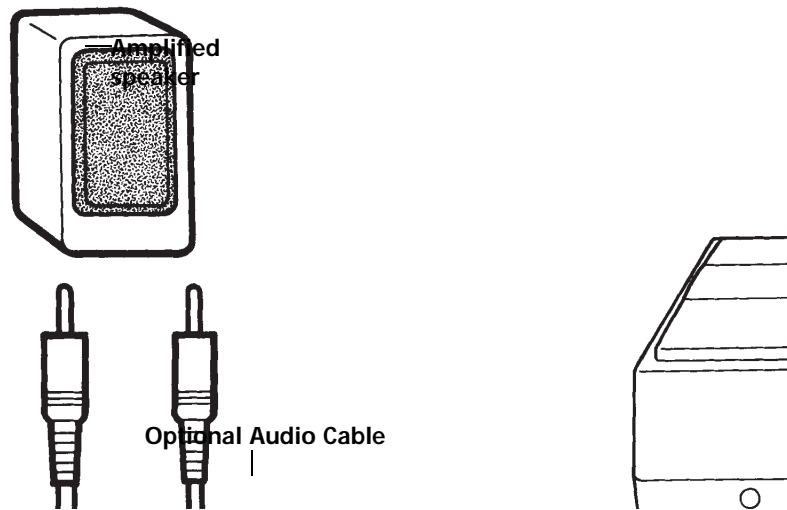

## Connecting the remote control by cable

If the projector cannot receive the remote's signal, as may be the case if you are using rear projection, you can connect the remote directly to the LitePro with a cable. The remote cable is an optional accessory available from your In Focus dealer.



**Note**  
Make sure the remote control cable is securely attached. If the cable is loose, the remote control may not work properly.

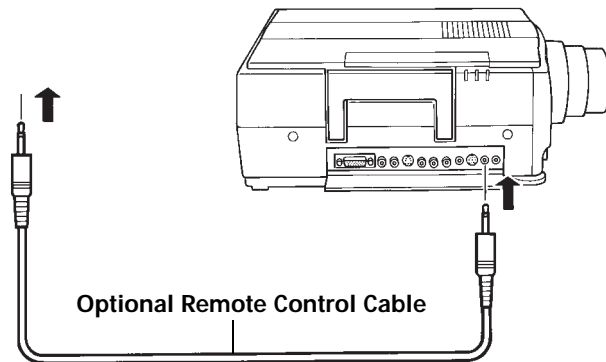

## Powering up and adjusting the LitePro 580

1. Turn the power switch on.
  - Allow ten seconds for the image to appear and 25 seconds for full illumination.
  - The lamp monitor begins flashing green. Once the projector has warmed up, the lamp monitor stops flashing and lights steadily in green.
  - If a computer or video player is attached, the video signal is projected. (If you are using a laptop computer, refer to the Appendix for laptop monitor re-activation commands.)

### **Warning**

Be very careful not to look directly into the lens when the projector is turned on. The bright light may harm your eyes. Be especially careful to keep children from looking into the lens.

2. Focus the image.
  - Turn the focus ring on the projector until the image is sharp.

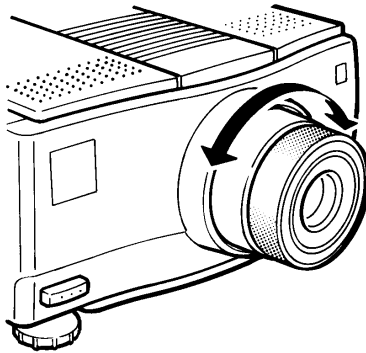

3. Adjust the projected image size.
  - First alter the distance from the projector to the screen, then adjust the image size by turning the X1.4 zoom lens ring until you have the desired image size.

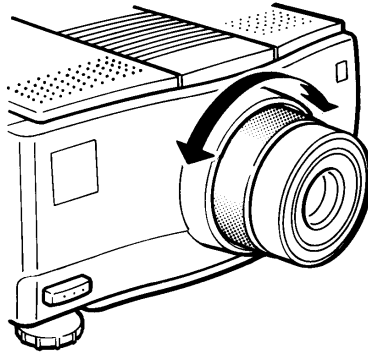

4. Adjust the height of the projected image.
  - Raise the front of the projector to the desired angle.
  - Press the elevator foot buttons until each foot touches the tabletop.

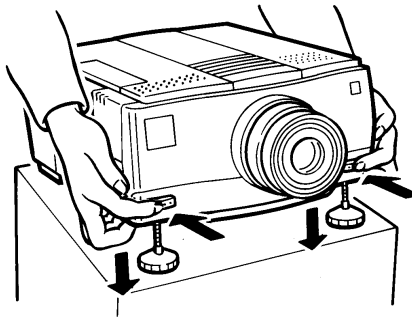

- Release the elevator foot buttons.
- Fine tune the height by manually turning each foot. Turn clockwise to lower the foot, counterclockwise to raise it, as shown in the illustration on the next page.

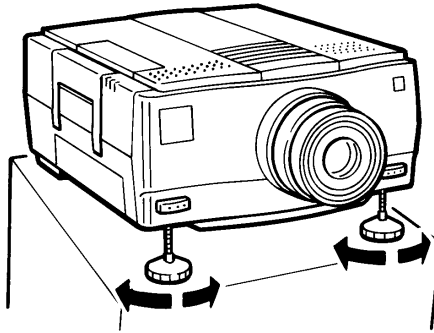

5. Adjust sync or brightness to fine tune the image.
6. Adjust the volume with the volume control on the projector or the remote control if you have audio input.

## Turning off the LitePro

If you want to turn off the projector for a short period of time, press the Standby button on the projector or the remote control. This turns off the lamp but keeps the projector running.

To completely power off the projector, turn the power switch off. If you want to turn the projector back on immediately, you must allow from 10 to 60 seconds for the lamp to cool. The lamp will not light if it is too hot.

Each time you power off the projector, its settings are retained in memory. These settings are then available to you the next time you turn on the projector.

### **Warning**

Be very careful not to look directly into the lens when the projector is turned on. The bright light may harm your eyes. Be especially careful to keep children from looking into the lens.



# ▼ Using the LitePro 580

This section explains how to operate the projector. It provides a reference to the projector and remote control buttons and the menu commands.

## Basic functions

The projector has two modes of operation: **display mode** and **menu mode**. In display mode, while images are projected, you can control image sync to stop flickering, image brightness, image freezing, volume, muting, and the source of the video signal. In menu mode you display menus where you can adjust the projector's settings.

Both display and menu mode controls are accessible from either the control panel on the projector or the remote control.

### Projector control panel

The control panel is on the top right side. Flip the cover up to gain access to the controls.

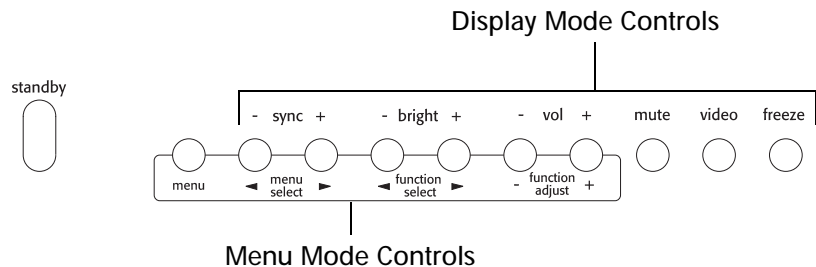

### **Remote control**

To use the remote control, point it at the front or rear of the LitePro or at the projection screen. The range for optimum operation is within 30 degrees of the receiver at a distance of about 35 feet (10 meters).

If you can't aim the remote control at the projector so that its signal is received—for example, when using rear projection—you can connect the remote directly to the projector with a cable. This optional cable is available from your In Focus dealer.

In menu mode, the trackball, the Adjust buttons, and the Menu Select button become active. For more information see “Menu mode controls” on page 24.

## Display mode controls

When your computer or video equipment is projecting an image, your projector is in display mode. The buttons on the projector or the remote control provide basic control of how the image is displayed. A summary of these controls follows:

**Lite Pro 580 basic display mode functions**

Button on projector	Button on remote	Function
Standby	Standby	Turns projector lamp on and off.
Sync + -	Sync + -	Adjusts flickering or blurred image. Synchronizes the projector to the computer input signal.
Bright + -	Bright + -	Adjusts the brightness of the image.
Freeze	Freeze	Freezes the image. To cancel, press any button.
Video	Video	Selects video equipment as the source of the signal to be projected. By default, the projector is set to computer input. Pressing the button again returns to computer input.
Mute	Mute	Shuts off the audio. To cancel, press the Mute button again or adjust Volume.
Volume + -	Volume + -	Adjusts the volume.
	Light	Illuminates buttons on the remote for 10 seconds. Press any button while the buttons are lit to extend the time for 10 seconds.
	Custom	Carries out a function you have assigned with the Custom Key menu. (See "Custom menu functions" on page 31.)

## Menu mode controls

The LitePro 580's on-screen menus allow you to adjust the projector's input, output, and operational settings. These include settings for:

- controlling computer input and output (Computer menu)
- controlling video input and output (Video menu)
- controlling how the image is displayed (Display menu)
- controlling audio input and output (Audio menu)
- controlling general operation options (Options menu)
- assigning a function to the remote's Custom button (Custom menu)

Buttons on the projector or the remote control provide control of menu settings. A summary of these controls follows:

**Lite Pro 580 menu mode functions**

<b>Button on projector</b>	<b>Button on remote</b>	<b>Function</b>
Menu	Menu	Brings up on-screen menu to adjust settings. To return to display mode, press the button again.
Menu Select < >	Menu Select	Selects the menu whose settings you want to change.
Function Select < >	Trackball	Selects the item on the menu you want to change.
Function Adjust - +	Adjust L (-) R (+)	Makes changes to the settings.

## Using the menus

To make adjustments to the projector's settings, place the projector in menu mode, select the desired menu and menu item, and then change the setting.

1. To place the projector in menu mode, press "Menu" on the projector or the remote control.
  - The Computer menu appears at the bottom of the screen.



If video equipment is attached to the projector, the Video menu appears. (You can choose to have the menu appear at the top of the screen. See "Menu" on page 28.)

2. Press "Menu Select" on the remote control or the projector to move to the desired menu.



3. Use the trackball on the remote or "Function Select" on the projector to choose an item on the menu that you want to adjust.



4. Press "Adjust" or "Function Adjust" to change the setting. Press "+" or "-" to adjust the settings.
5. Press "Menu" to remove the menu from the screen and return to display mode.

## Reference to menu functions

### Computer menu functions

Menu item	Function
Source	Indicates input is from a computer or video equipment.
Brightness	Adjusts image brightness; increases or decreases the brightness of white.
Contrast	Adjusts image contrast; increases or decreases the difference in brightness between black and white.
Sync	Adjusts picture synchronization to get rid of fuzzy horizontal lines.
Tracking	Adjusts picture tracking to get rid of fuzzy vertical lines.
Red	Adjusts the intensity of red.
Green	Adjusts the intensity of green.
Blue	Adjusts the intensity of blue.
Text	Compresses image display of DOS text screens wider than the projector's image area. Select only if using DOS.
Mac LC	Adjusts tracking and removes fuzzy vertical bars when using <u>any Macintosh</u> . This option appears and replaces "Text" when a Macintosh is connected. Select only if connected to a Macintosh.
Reset	Deletes changes and resets all items on this menu to default settings. When selected, a dialog box appears asking you to confirm this action.

### Note

This menu is available only when the source of input is a computer.

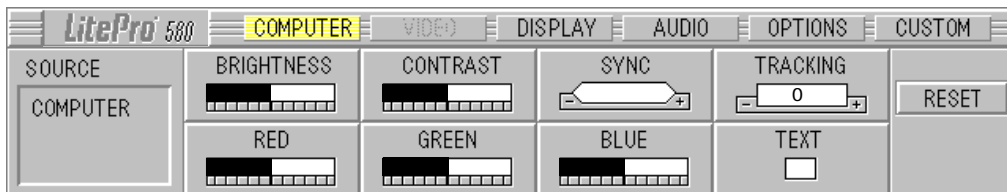

### Video menu functions

Menu item	Function
Source	Indicates input is from a computer or video equipment.
Brightness	Adjusts image brightness; increases or decreases the brightness of white.
Contrast	Adjusts image contrast; increases or decreases the difference in brightness between black and white.
Sharpness	Sharpens the image.
Color	Adjusts image color saturation or density.
Video Mode	Switches video broadcast format. Choose "Auto" for automatic switching or lock the unit into NTSC, PAL, or SECAM format.
Tint	Adjusts the balance between red and green.
Reset	Deletes changes and resets all items on this menu to default settings. When selected, a dialog box appears asking you to confirm this action.

### Note

This menu is available only when the source of input is video equipment.

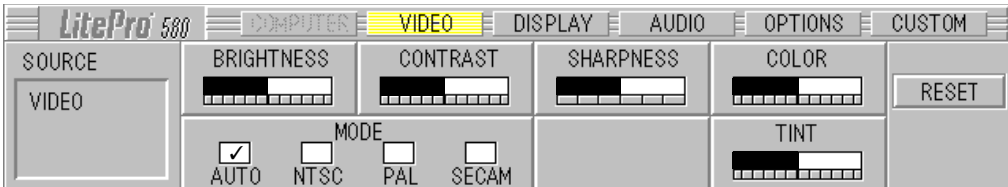

### Display menu functions

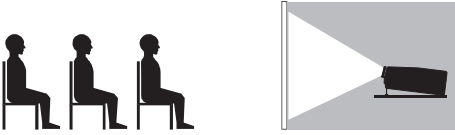
Menu item	Function
Source	Indicates input is from a computer or video equipment.
Horiz	Adjusts the horizontal display position of the image.
Vert	Adjusts the vertical display position of the image.
Menu	Indicates where menu will be displayed on screen. Select bottom or top display.
Blank to	Sets the color of the display when the screen is blank. Choose "Blue," "White," or "Black."
Rear Proj	Flips the image horizontally (left to right) for use in rear projection.  
Upside down	Flips the image vertically (top to bottom).
Invert	Reverses the colors of the projected image. Used mainly for black and white displays.
Reset	Deletes changes and resets all items on this menu to default settings. When selected, a dialog box appears asking you to confirm this action.





### Audio menu functions

Menu item	Function
Source	Indicates input is from a computer or video equipment.
Volume	Adjusts sound volume.
Balance	Adjusts sound balance between the left and right speaker.
Audio Source	Activates the audio input from the computer source (C), the video source (V), or from either active source (C or V).
Bass	Adjusts low tones.
Treble	Adjusts high tones.
Loudness	Turns bass boost on and off.
Fade	Adjusts the audio level between the internal speaker and the external sound source. If using external speakers, set to "E."
Reset	Deletes changes and resets all items on this menu to default settings. When selected, a dialog box appears asking you to confirm this action.

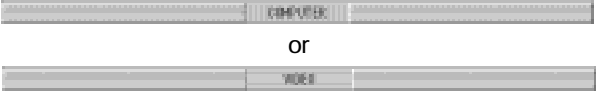

### Options menu functions

Menu item	Function
Source	Indicates whether input is from a computer or video equipment.
Prompt	Displays temporarily at the top of the screen the source of the input. 
Backgnd	Chooses the background pattern that is displayed when the projector and lamp are running and no input signal is being received. Select "Test Pattern," "Black" background, or "Blue" background.
Serial	Enables LP Utilities. (See "Using LP Utilities" starting on page 35.)
Power Save	Adjusts the number of minutes projector must be idle before the lamp turns off to save power. If set to 0, this function is disabled.
Dly on	Places projector in standby mode when powered on.
Language	Switches the language used in the menus. Select English, German, French, Spanish, Italian, or Japanese.
Reset ALL	Deletes all changes and resets all items on all menus to default settings. When selected, a dialog box appears asking you to confirm this action.



## Custom menu functions

Menu item	Function
Source	Indicates input is from a computer or video equipment.
Pattern	Enables the remote's Custom button to blank the screen to a test pattern.
Serial	Enables the remote's Custom button to activate LP Utilities. (See "Using LP Utilities" starting on page 35.)
Blank	Enables the remote's Custom button to blank the screen to blue, white, or black. The result depends on the setting of the "Blank To" option on the Display menu.
Prompt	Enables the remote's Custom button to display on screen the source of the projected image.
Reset	Deletes changes and resets all items on this menu to default settings. When selected, a dialog box appears asking you to confirm this action.

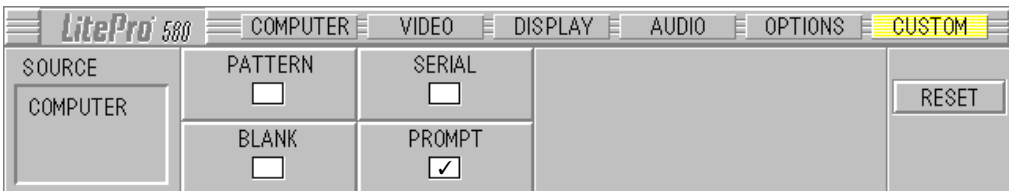

## ▼ Using LP Utilities

The LitePro 580 projector provides even greater ease of use with LP Utilities, which include two software programs: LP-Link and LP Remote Programmer.



LP-Link allows you to operate the projector directly from the computer.



LP Remote Programmer allows you to use the trackball and five programmable buttons on the remote control to operate the presentation software and control projector functions. To use these utilities you must connect your computer to the projector with the LP serial cable and run the LP Utility software.

### Connecting your computer

To connect the projector and your computer, use the LitePro Utilities serial cable (and adapter if needed) provided with the projector.

1. Turn off your computer, monitor, and LitePro projector.
2. Plug the round, 8-pin connector of the LP serial cable into the LP Serial port on the projector.
3. Plug the other end of the LP serial cable into the serial port on the computer. For a Macintosh, attach the Mac adapter to the serial cable and plug it in the modem or printer port.

#### ▼ Note

If your IBM-compatible has only a 25-pin serial port, you will need a 25-pin serial adapter. This adapter is available at most computer supply stores.

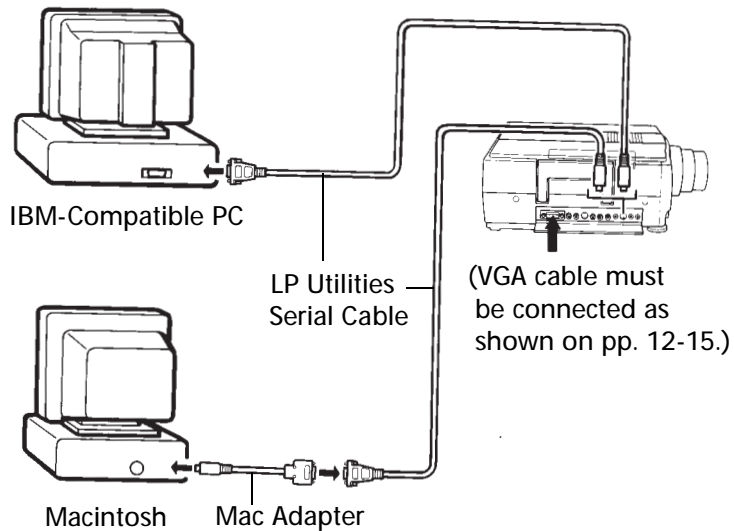

4. Turn on the projector, monitor, and computer.

## Installing the LP Utilities software

To install the LitePro Utilities software, insert the LP Utilities diskette into your computer.

For IBM-compatible computers, running Microsoft Windows™:

- Select Run from the Program Manager's File menu.
- Enter A:\SETUP (if you inserted the diskette in drive A:) to start the installation process.

For Macintosh computers:

- Double-click the diskette icon to open it.
- Double-click the LP Utilities icon to start the installation process.

## LP-Link Utility

The LP-Link utility allows you to control your projector from your computer. Having this control on the computer monitor avoids displaying menus and making adjustments on the projection screen during a presentation.

Launch the LP-Link program and a window opens displaying two areas:



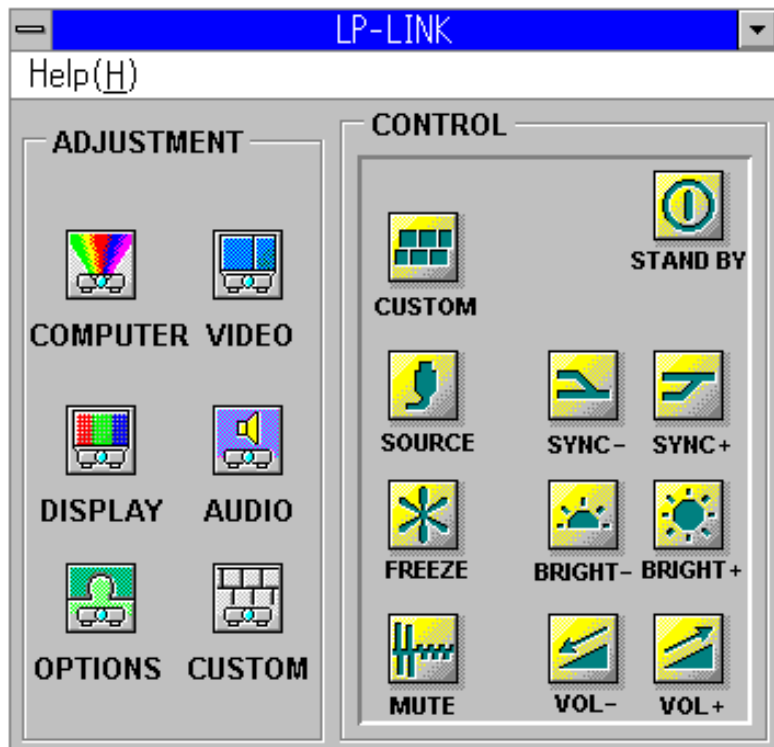







- a control panel on the right, marked “Control,” to control basic functions, and
- individual control panels on the left, marked “Adjustment,” to adjust settings.



## Using the control icons

The LP-Link function controls are the same as those on the projector and the remote. Select a button to change its setting. Select and hold down the mouse button to increase or decrease values. A list of the controls follows:

LP-Link control icons

Icon	Command	Function
	Standby	Turns projector lamp on and off. (If the LitePro is in standby mode, this is the only icon that is displayed.)
	Sync (-)	Adjusts a flickering or blurred image. Synchronizes the projector to the computer or video input signals.
	Sync (+)	Adjusts a flickering or blurred image. Synchronizes the projector to the computer or video input signals.
	Bright (-)	Decreases the brightness of the image.
	Bright (+)	Increases the brightness of the image.
	Volume -	Decreases the volume.
	Volume (+)	Increases the volume.
	Custom	Carries out a function you have assigned with the Custom Key menu.
	Source	Selects either a computer or a video device as the source of the signal to be projected.
	Freeze	Freezes the image. To cancel, click the icon again.
	Mute	Shuts off the audio. To cancel, click the icon again.

## Using the adjustment control panels

LP-Link's adjustment control panel allows you to adjust the projector's input, output, and operational settings.

### Adjusting the Computer settings

1. Double-click the Computer control panel icon.
  - The Computer settings dialog box appears.

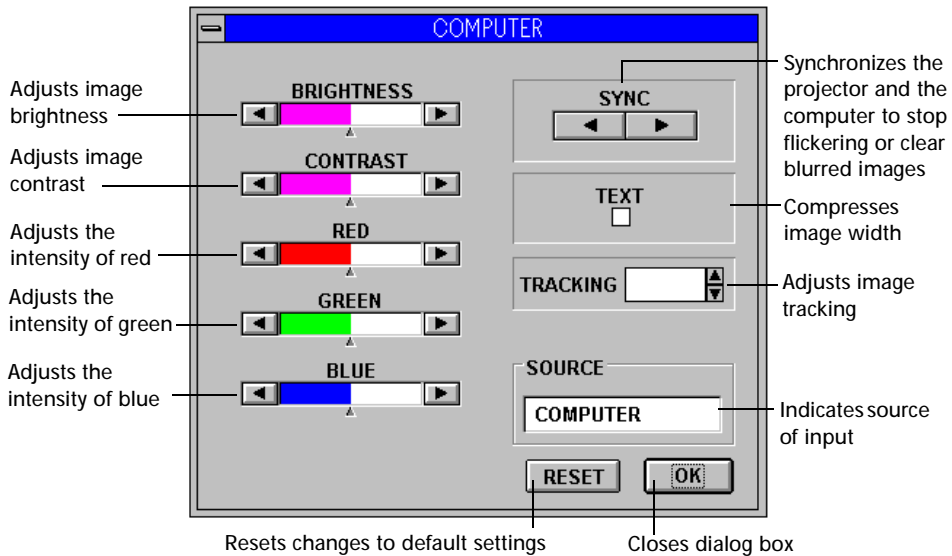

2. Make the desired changes.
  - Click any active arrow to increase or decrease a value.
  - Click the Text check box to select it. Click it again to deselect it.
  - Click "Reset" to reset the value to their original settings.
3. Close the dialog box.
  - Click "OK" to save any changes and close the dialog box.

### **Note**

You cannot access this dialog when video is being displayed.



## Adjusting the Video settings

1. Double-click the Video control panel icon.
  - The Video settings dialog box appears.

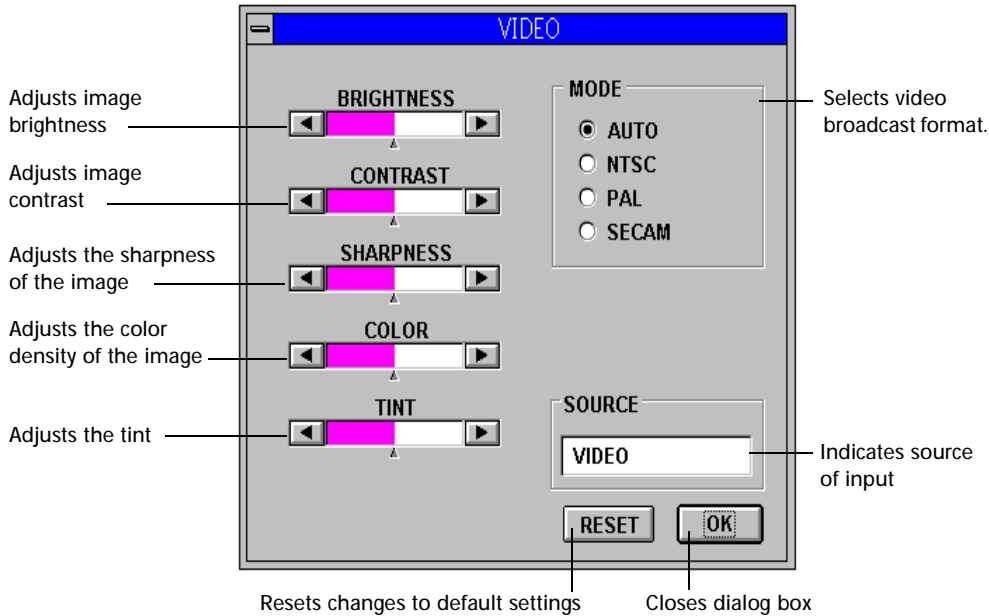

2. Make the desired changes.
  - Click any active arrow to increase or decrease a value.
  - Click an option button under Mode to select one of four options.
  - Click “Reset” to reset the value to their original settings.
3. Close the dialog box.
  - Click “OK” to save any changes and close the dialog box.

### Note

You cannot access this dialog when computer input is being displayed.

## Adjusting the Audio settings

1. Double-click the Audio control panel icon.
  - The Audio settings dialog box appears.

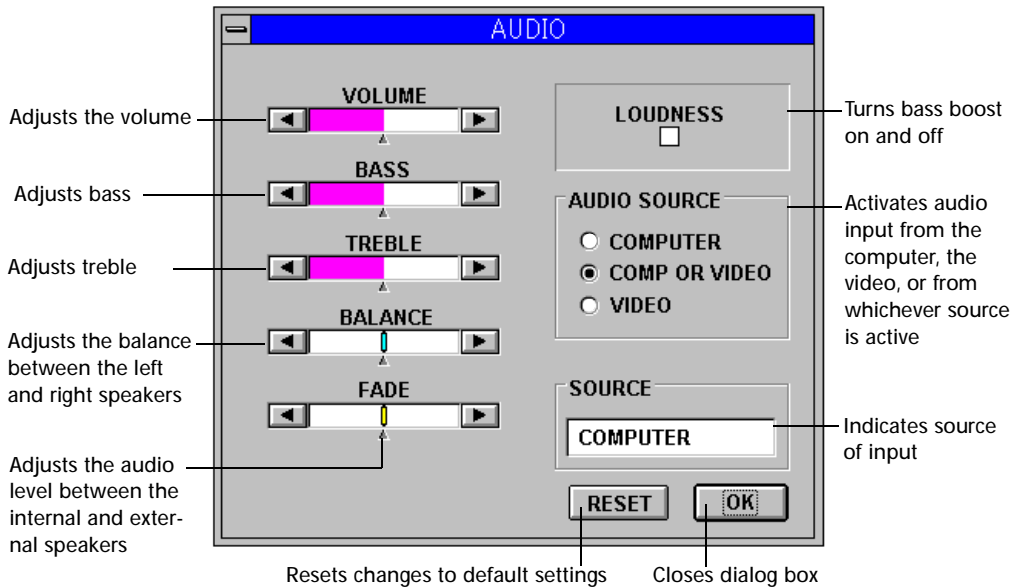

2. Make the desired changes.
  - Click any arrow to increase or decrease a value.
  - Click the Loudness check box to select it. Click it again to deselect it.
  - Click an option button under Audio Source to select one of three options.
  - Click "Reset" to reset the value to their original settings.

3. Close the dialog box.
  - Click "OK" to save any changes and close the dialog box.

## Adjusting the Display settings

1. Double-click the Display control panel icon.
  - The Display settings dialog box appears.

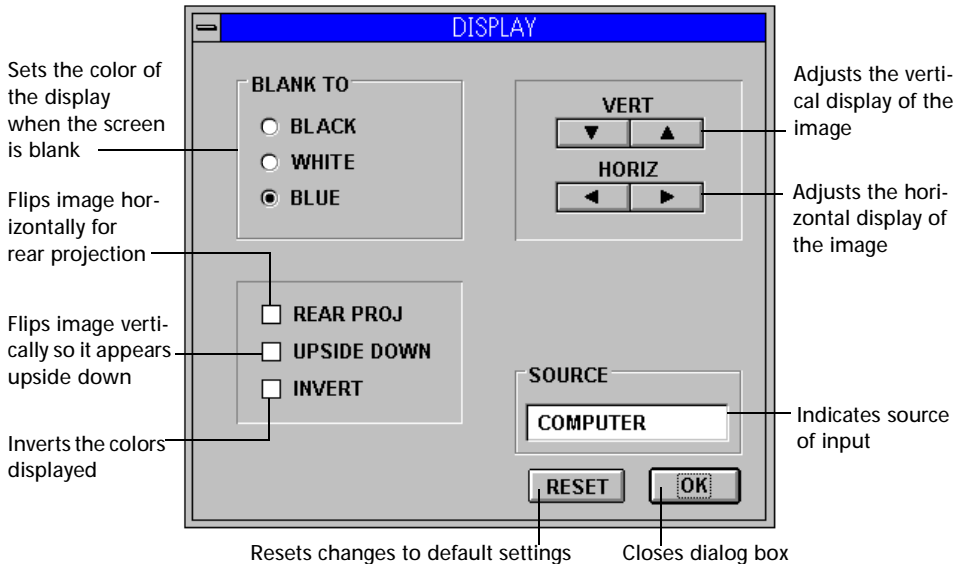

2. Make the desired changes.
  - Click an option button under Blank To to select one of three options.
  - Click any arrow to increase or decrease a value.
  - Click a check box to select it. Click it again to deselect it.
  - Click "Reset" to reset the value to their original settings.
3. Close the dialog box.
  - Click "OK" to save any changes and close the dialog box.

## Adjusting the Options settings

1. Double-click the Options control panel icon.
  - The Options settings dialog box appears.

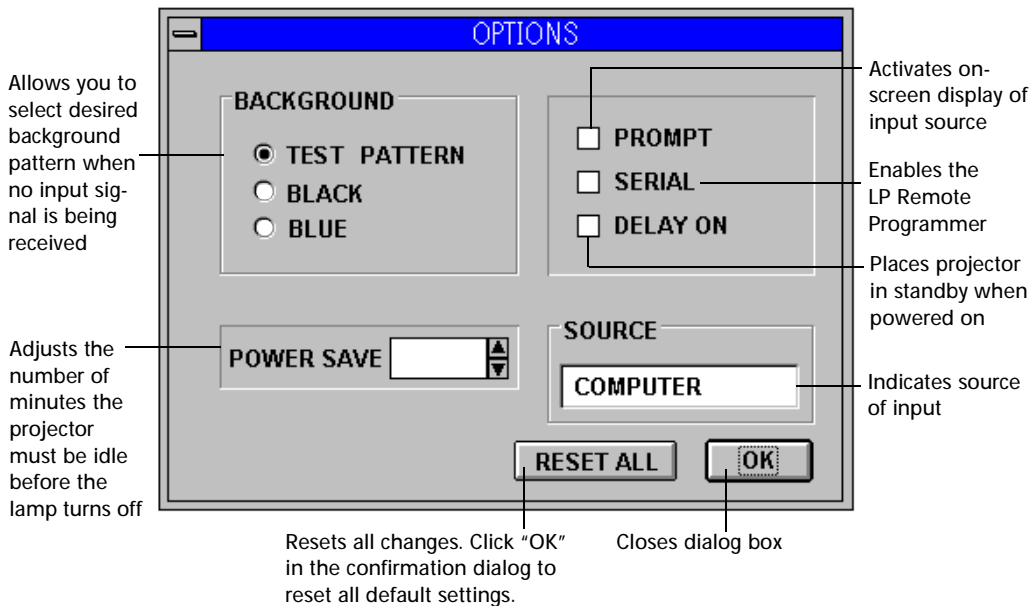

2. Make the desired changes.
  - Click an option button under Background to select one of three options.
  - Click any active arrow to increase or decrease a value.
  - Click a check box to select it. Click it again to deselect it.
  - Click "Reset" to reset the value to their original settings.
3. Close the dialog box.
  - Click "OK" to save any changes and close the dialog box.

## Adjusting the Custom settings

1. Double-click the Custom control panel icon.
  - The Custom Key settings dialog box appears.

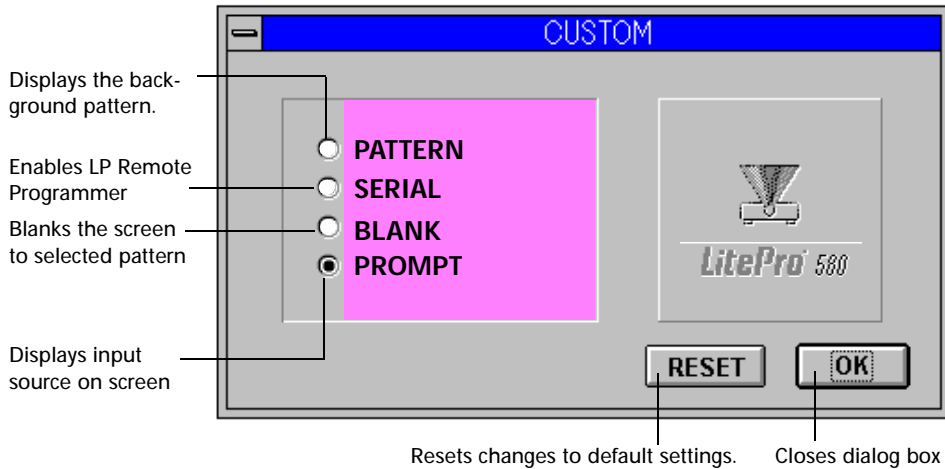

2. Assign a function to the Custom key on the remote.
  - Click an option button to select one of four options.
  - Click “Reset” to reset the values to their original settings.
3. Close the dialog box.
  - Click “OK” to save any changes and close the dialog box.

## LP Remote Programmer Utility

LP Remote Programmer allows you to use the remote's trackball as you do your computer's mouse, control presentation software as an electronic clicker, and customize buttons to carry out commands. It also provides button templates for popular presentation software applications.

### Programmable buttons

Five of the buttons on the remote control unit are programmable. You can assign a sequence of up to 32 keystrokes to each of these buttons. For example, instead of typing CTRL + TAB to advance to the next screen, you can assign this sequence to one of the buttons. Then, pressing the button has the same effect as typing CTRL + TAB.

### LP Remote Programmer dialog box

All buttons except the five programmable ones are displayed in gray to indicate that they are unavailable. The text box next to each programmable button shows the keystrokes currently assigned to it.

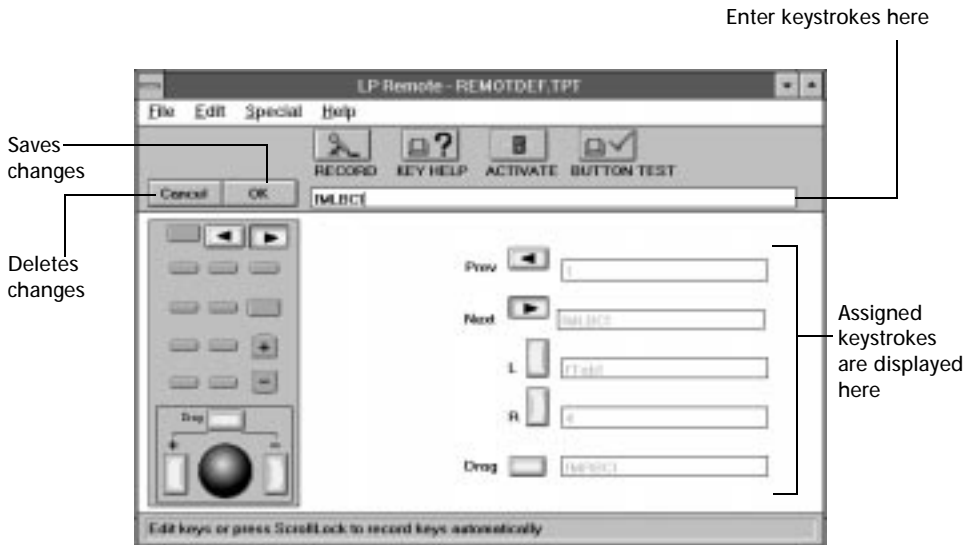

## Macros and templates

A sequence of keystrokes assigned to a button is called a macro. A set of macros is stored in a file called a template. You can create as many templates as you like: one for each presentation software application, for example.

The first time you launch LP Remote Programmer, it opens the default template. In the illustration on the previous page, a template named REMOTDEF.TPT is opened.

## Programming a button

There are two ways to assign a macro to a button: you can record it or type it. Recording keystrokes is usually preferable. However, if the macro includes control keys (CTRL, ALT, SHIFT, etc.), you should type the characters and codes in the text box.

To record a macro:

1. Click the button you want to program. (You can also press Enter on an IBM-compatible computer or Select on a Macintosh to select a button to program.)
  - The text box at the top of the window displays the keystrokes that are already assigned to the button.
2. Click the Record button to start recording. (You can also press the Scroll Lock key on an IBM-compatible computer to start recording.)
3. Type the keystrokes you want to assign to the button, up to 32 keystrokes.
  - If you are using an IBM-compatible computer and the keystroke sequence includes the Scroll Lock key, click the Record button to stop recording, type [SC] (including the brackets), then click Record to start recording again.
4. Click "OK" to stop recording.
5. Repeat steps 1-4 for the other buttons.
6. Save the template by choosing "Save" from the File menu.

To type a macro:

1. Click the button you want to program. (You can also press Enter on an IBM-compatible computer or Select on a Macintosh to select a button to program.)
  - The text box at the top of the window displays the keystrokes that are already assigned to the button.
2. Enter the keystrokes you want to assign to the button, up to 32 keystrokes. For alphanumeric (character) keys, simply type the key. If you want to include non-character keys in your macro, follow the guidelines below for either IBM-compatible computers or Macintosh computers.

To include non-character keys on IBM-compatible computers:

- Type the code enclosed in brackets. Click the Key Help button to display a list of the non-character key codes.
- If two control keys are to be pressed at the same time, put brackets around the entire combination. For example, if Control and Alt are to be pressed at the same time, type `[[CTRL][ALT]]`.
- To assign mouse clicks to a button: select the button to be programmed, select “Mouse Button” from the Special menu, then choose the desired mouse click. You can also type the code for the mouse click in the text box next to the button. The codes are listed here:

Mouse button	Code
Left Button Click	[MLBC]
Left Button Double-Click	[MLBDC]
Left Button Down	[MLBD]
Left Button Up	[MLBU]
Left Button Drag On/Off	[MLBDG]
Right Button Click	[MRBC]
Right Button Double-Click	[MRBDC]
Right Button Down	[MRBD]
Right Button Up	[MRBU]
Right Button Drag On/Off	[MRBDG]



To include non-character keys on Apple Macintosh computers:

- Use the recording method as described on the previous page; simply press the keys you want to include. Open “Mouse/Special Buttons” in the Special menu to insert non-character keys.
  - If two non-character keys are to be pressed at the same time, use the “Link” special key to connect the keys. For example, if the X key and the Control key are to be pressed at the same time, open “Mouse/Special Buttons” in the Special menu, insert the Control key code, insert the Link key code, then press X.
  - To assign mouse clicks to a button: select the button to be programmed, select “Mouse/Special Buttons” from the Special menu, then choose the desired mouse click.
3. Repeat steps 1 and 2 for the other buttons.
  4. Save the template by choosing “Save” from the File menu.

### Activating and verifying the template

Once you have programmed the buttons in a new template—or if you open another template—you must activate the template so that the remote buttons carry out the assigned macros. To do this, click the Activate button or choose “Activate” from the Special menu. A dialog box appears indicating that the template was activated.

To verify the keystroke sequence programmed to a button, click the Button Test button or choose “Button Test” from the Special menu. A text box appears. Press a programmed button. LP Remote Programmer displays the keystrokes assigned to the button.

### Note

To increase or decrease trackball speed on the remote control, choose the desired speed from “Mouse Speeds” in the Special menu.

## ▼ Maintenance

This section describes how to:

- clean the lens
- clean the air filter
- replace the projection lamp
- replace the batteries in the remote control
- replace the fuse

### **Warning**

**Do not open the LitePro case!**

Except for the projection lamp, there are no user-serviceable parts inside. Opening the case may cause electric shock! If you are having problems with your LitePro, refer to the “Troubleshooting” section of this manual. Call In Focus Technical Support if necessary. If your LitePro needs repair, they will refer you to an In Focus Authorized Service Provider.

## Cleaning the lens

Follow these steps to clean the projection lens.

1. Apply a non-abrasive glass cleaner to a soft, dry cleaning cloth.
  - Be careful not to use excessive amounts of cleaner.
  - Abrasive cleaners, solvents or other harsh chemicals may scratch the lens.
2. Lightly wipe the cleaning cloth over the lens.
3. If you will not be using the LitePro immediately, replace the lens cover.

## Cleaning the remote control

Avoid getting dirt, dust or hand lotion on the remote's trackball. If the trackball gets dirty, it will not work properly. Follow these steps to clean the trackball and the remote control.

1. Turn off the projector.
2. Using 2 pointed objects, such as pens, remove the trackball cover. Put the pointed ends into the two holes in the trackball cover.
3. Turn the cover counter-clockwise about one-half turn until it comes off.
4. Remove the trackball.
5. Wipe the trackball gently with a soft, dry cloth. If necessary, dampen the cloth with a mild detergent. Do not use alcohol solvents on the trackball.
6. If necessary, use a cotton swab to clean the inside of the trackball mechanism. Be very careful not to press hard on the rubber roller; if it gets out of alignment, the trackball will not work properly.
7. Replace the trackball.
8. Replace the trackball cover. Turn it clockwise to lock it in place.

## Cleaning the fan intake filter

The fan intake filters on the bottom and top of the projector catch dust and particles in the air. If a filter becomes clogged, the projector will not cool properly and may malfunction. To prevent this, clean the filters after every 100 hours of use.

To clean the filter:

1. Turn off the power and unplug the power cable.
2. Remove the filter.
  - Carefully place a screwdriver against the indented part of the filter and lift.

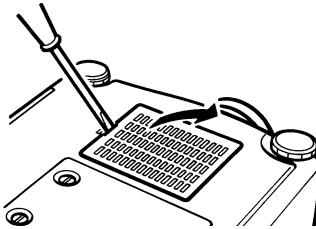

3. Clean the filter.
  - Use a vacuum cleaner set on low power to remove the dust and dirt.

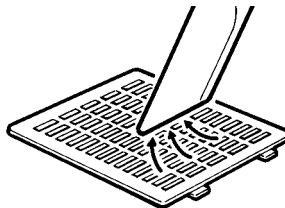

4. Replace the filter.
  - First, insert the side with tabs, and then press the other end in place.

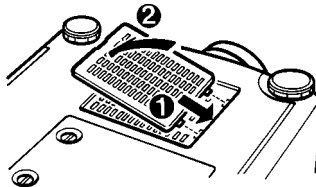

- If the filter cannot be cleaned or is damaged, contact your In Focus dealer for a replacement.

## Replacing the projection lamp

If the lamp fails to come on and the lamp monitor on the projector lights in red, you must replace the bulb. Be sure to replace it with another metal halide lamp.

You can order replacement lamps from In Focus. Refer to “Order information” on page 66 for information.

Follow these steps to replace the lamp module.

1. Turn off the projector and unplug the power cord. Allow the projector to cool thoroughly.

### **Warning**

Allow the LitePro to cool for at least 20 minutes before you open the lamp cover! The inside of the LitePro can become very hot. Use extreme care.

2. Remove the lamp cover on the bottom of the projector.
  - Loosen the two screws with a screwdriver or a coin.
  - Pull the lamp cover up to remove it.

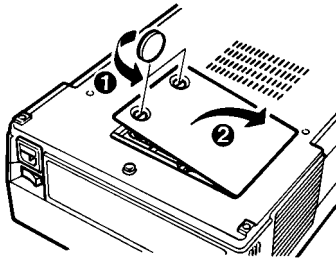

3. Pull out the lamp.
  - Loosen the two screws holding the lamp in place.
  - Pull up on the handle to remove the lamp.

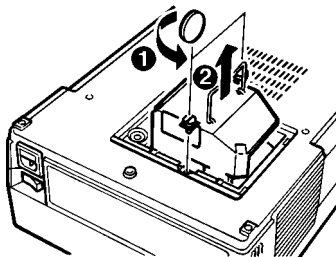

**Warning**

Do not drop the lamp module or touch the glass bulb! The glass can shatter and cause injury.

4. Fit the new lamp in place.
  - Align the lamp in the correct direction.
  - Lightly press on it until it touches bottom.
  - Tighten the two screws.

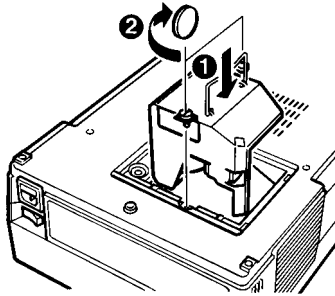

5. Replace the lamp cover.
  - Reposition the cover in place.
  - Replace the screws and tighten them.

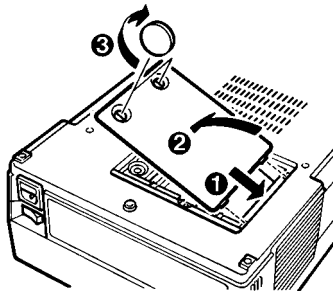
**Caution**

Never operate the LitePro with the lamp cover open or removed. This disrupts the airflow and causes the LitePro to overheat.

## **Replacing batteries in the remote control**

The life of the remote batteries depends on how often and how long you use the remote. Symptoms of low battery charge include erratic responses when using the remote and a reduced range where the remote works.

Follow these steps to replace the batteries.

1. Slide the battery cover off the end of the remote.
2. Remove the old batteries.
3. Install two new AAA alkaline batteries. Make sure each is installed in the correction orientation.
4. Slide the battery cover back on the remote.

## Replacing the fuse

A power surge or spike can blow the power supply fuse and cause the LitePro to stop working. If this happens, you'll need to replace the fuse.



Use only the specified power supply fuse. Using a different fuse may cause serious damage to the LitePro.

The correct fuse for your LitePro is a 6.3A, 250V, T, 5x20 mm fuse.

Follow these steps to replace the fuse.

1. Make sure that the condition that caused the fuse to blow no longer exists.
2. Turn off and unplug the projector.
3. Remove the fuse holder, located just below the power cord connector, from the projector.
  - Pull out the fuse holder with a screwdriver as shown.

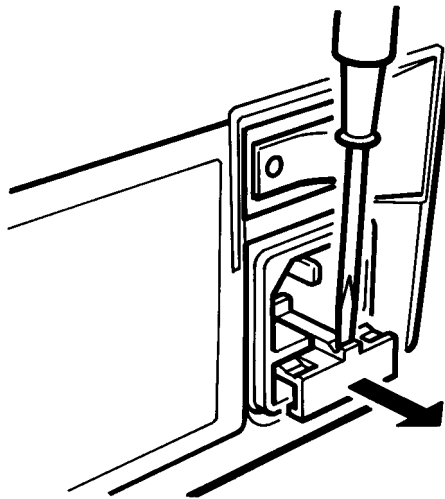



4. Remove the blown fuse from the fuse holder.

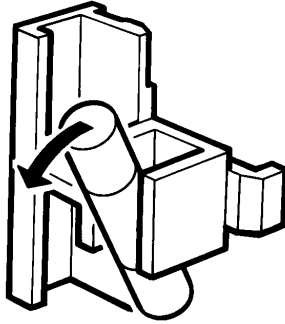

5. Push the new fuse into the clips of the holder until it is securely seated.
6. Place the fuse holder back in position.

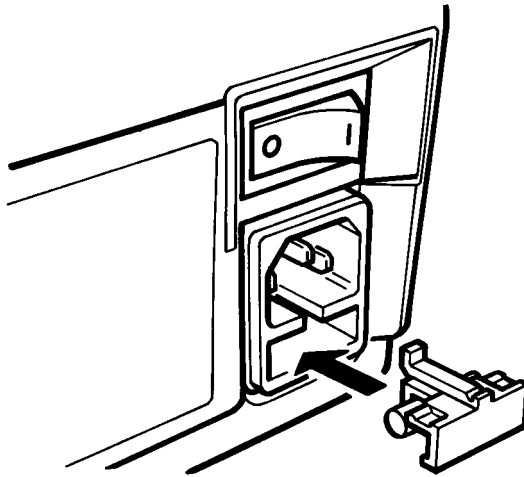

## ▼ Troubleshooting

### **Warning**

**Do not open the LitePro case!**  
Opening the case may cause electric shock!  
Except for the projection lamp, there are no user-serviceable parts inside. If you are having problems with your LitePro, read through this section. Call In Focus Technical Support if necessary. They will refer you to an In Focus Authorized Service Provider if your projector needs repair.

### **Before you call for assistance**

Before calling your dealer for assistance, follow these steps in this order to make sure everything is properly connected.

1. Make sure you have connected the LitePro to your equipment as described in section “Setting up the LitePro 580” beginning on page 7.
2. Check cable connections. Verify that all computer, video, and power cables are properly connected.
3. Verify that all power is switched on.
4. If the LitePro still does not display an image, reboot the computer.
5. If the image is still bad, unplug the LitePro from the computer and check the computer monitor’s display. The problem may be with your graphics controller rather than with the LitePro. (When you reconnect the LitePro, remember to turn the computer and monitor off before you power up the LitePro. Power the equipment back up in this order: LitePro, monitor, computer.)
6. If the problem still exists, read through the problems and solutions in this chapter.

## Common problems and solutions

### **Problem: Projector doesn't turn on**

- Make sure power cord is plugged in firmly.
- Make sure projector is plugged in a live AC outlet or power strip.
- Check to see that the projector is not too hot to operate and that the temperature monitor light is not orange.
- If the projector lamp was replaced, make sure the new one is fitted correctly and the lamp door is properly fastened.
- Check the fuse to see if it has blown.

### **Problem: Nothing on screen**

- Make sure you have removed the lens cover.
- Verify that computer or video cables are connected to the correct ports on the projector and the computer or video equipment.
- Press the Standby button. This toggles the lamp on and off.
- Make sure no cable connector has a bent pin.
- Make sure the lamp is not too hot to operate. It will not light if it is.

### **Problem: Picture is blurred or only part of image is in focus**

- Focus the lens.
- Make sure the projector is not too close or too far from the screen.
- Make sure the projector is at a right angle to the screen.
- Adjust Sync.
- Adjust Brightness.
- Adjust Tracking.

### **Problem: Image is not centered on the screen**

- Adjust the Horizontal and Vertical settings on the Display menu.

**Problem: Poor color**

- Adjust Brightness.
- Adjust Color.
- Adjust Tint.
- Adjust Red, Green, and Blue.
- Use a shorter cable between video source and the projector.
- Verify that the projector is set to receive the appropriate video broadcast format.

**Problem: Only the test pattern is displayed**

- Verify all cable connections. Check to see that the cable is connected to the graphics/monitor port on the computer.
- Check that your computer graphics system is set up correctly. If you have a CGA or EGA board, you cannot use the cable that was shipped with the LitePro (it's a VGA cable). Call In Focus to order a CGA/EGA cable.
- Make sure your computer's graphics board or external video board is turned on.

**Problem: No image on the computer screen**

- Make sure the monitor is turned on.
- Verify that the VGA cable is connected correctly.

**Problem: No sound**

- Verify audio input/output connections.
- Adjust Audio Source.
- Adjust Volume.
- Press the Mute button.
- Adjust Fade to balance the internal and any external speaker.

**Problem: Image is too wide or narrow for screen**

- Adjust Tracking to reduce or enlarge the projected image.

**Problem: Fuzzy vertical bars in image**

- Adjust Tracking.
- If your computer is a Macintosh, select the “Mac LC” box in the LitePro’s Computer menu (see page 26).
- Make sure your cables are connected correctly and adjust signal synchronization from the remote.

**Problem: Image and menus are reversed left to right**

- Rear projection is turned on. Select “Rear Proj” on the Display menu to turn it off.

**Problem: LitePro displays vertical lines, “bleeding” or spots**

- Adjust Brightness.

**Problem: Image is “noisy” or streaked with horizontal lines**

- Adjust Sync.

**Problem: Dim image**

- Adjust Brightness.
- Adjust Contrast.
- Replace lamp if it has been used for over 500 hours.

**Problem: Remote control doesn’t work**

- Check the batteries. They may need to be replaced or they may be loaded incorrectly.
- Make sure nothing is blocking the remote control receiver on the projector.
- Make sure you are not too far from the projector when using the remote. It has a limited range.

The projector has three lights that monitor its operations:

1. Operation monitor—indicates the projector is on, is in Standby mode, or is receiving signals from the remote control.
2. Lamp monitor—indicates if lamp is warming up, lit, or cooling down.
3. Temperature monitor—indicates if projector is overheating.

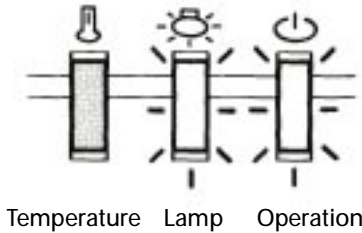

## Temperature monitor

Color	Explanation
Flashing orange	Internal temperature of projector is high. Cooling fan turns at higher speed. (Solution: Make sure nothing is obstructing the fan intake grill. Turn off lamp by pressing “Standby” and allow lamp to cool.)
Orange	Internal temperature of the projector is too high. Lamp turns off automatically (Solution: Make sure the fan intake grill is not obstructed or dirty. Allow projector to cool before turning on lamp by pressing “Standby.”)

**Lamp monitor**

<b>Color</b>	<b>Explanation</b>
Flashing green	Lamp warming up.
Green	Lamp operating.
Flashing orange	Lamp cooling down.
Flashing red	Lamp is not working. (Solution: Press Standby button or change lamp.)

**Operation monitor**

<b>Color</b>	<b>Explanation</b>
Orange	Projector in Standby.
Green	Projector and lamp operating.
Flashing green	Signal from remote control being received.
Flashing red	Problem with the projector. (Solution: Turn power switch off and then on.)

# ▼ Appendix

## Compatibility and cabling

The LitePro 580 provides an image resolution of 640 by 480 pixels with up to 16 million colors. It is compatible with various computer graphics and video formats.

Source	Format	Resolution	Cable
IBM compatible	VGA, VESA, NEC, JEGA, MDA*, CGA, Hercules*, ATT*	640x480 640x200 640x400 640x350 720x350** 720x400** 800x600**	VGA cable supplied with projector
Apple/Macintosh (includes Apple II, Mac II, LC, Performa, Quadra, PowerBook and Power Macintosh)	Standard graphics, 8- and 24-bit color monitor	640x480 640x400	VGA cable with Mac adapters supplied with projector
Video (Composite)	NTSC PAL, SECAM	640x480 768x576**	A/V cable supplied with projector
Video (S-Video)	NTSC PAL, SECAM	640x480 768x576**	S-Video cable

\* Monochrome only; requires special cable.

\*\* The LitePro 580 displays only 640x480 images; images of higher resolution will be compressed or cropped.

## About broadcast video

Most broadcast video signals in the world are one of three standards:

- NTSC (National Television Standards Committee)—a 60 Hz 525-line resolution standard used in North America, parts of South America, and Japan.
- PAL (Phase Alternating Line)—a 50 Hz 768x576 resolution standard used in Europe, Australia, China, and some South American and African countries.



- SECAM (Sequentiel Couleur à Mémoire)—a 50 Hz 768x576 resolution standard similar to PAL used in France, Eastern Europe, and some African and Middle Eastern countries. PAL and SECAM differ in the way color information is encoded on the broadcast signal.

Video produced by VCRs, laser disc players, and camcorders is sent and received in one of two formats:

- Composite video—carries sync, luminance (the black and white part of the video signal), and color information on one signal with a single pin and ground connection, and
- S-Video—separates color information from the luminance and sync signal with a four-pin and ground connection. Because of the color separation, S-Video produces a higher quality display with better colors and less noise. It is not recommended for use over distant connections as the signal tends to degrade the longer the it must travel.

## About computer video

Computer video generates five separate signals for IBM compatible computers: red, green, blue, H-sync and V-sync. It provides four separate signals for Macintosh computers: red, green, blue, and composite sync. These types of signal are called RGB for red, green, and blue.

## Specifications

The LitePro must be operated or stored within the limits of these specifications.

### Projection Lamp

---

Type	150W 65V metal halide short-arc
Life	Average 600 hours to 50% of initial brightness

### Fuse

---

Type	6.3A. 250V.T. 5x20mm
------	----------------------

### Power Requirements

---

100-120 VAC	3.5A, 50/60 Hz
220-240 VAC	1.3A, 50/60 Hz

### Remote Control

---

Battery	Three (3) AAA alkaline cells
Range	Approximately 35 feet (10 m.) when aimed at the projector or reflected off a white wall or projection screen within 30° of the projection axis

### Optical

---

Aspect ratio	4 (H) X 3(V)
Brightness	average 200 lumens (measured by ANSI 9 point method)
Uniformity	1.3:1 maximum (measured by 12 point method)
Projection range	3.9 to 40.4 feet (1.2 to 12.3 m)
Zoom ratio	1:1.4
Image size	21 in. to 300 in. (.5 m to 7 m)

### Temperature

---

Operating	5° to 40° C
Non-operating	-20° to 60° C

**Altitude**

Operating	0 to 10,000 feet (3000 meters)
Non-operating	20,000 feet (6000 meters)

**Humidity**

Operating	20 to 80% RH, non-condensing
Non-operating	10 to 90% RH, non-condensing

**Dimensions**

LitePro 580	11.22 [W] x 5.51(5.87) [H] x 13.54(16.26) [D] inches 28.5 [W] x 14(14.9) [H] x 34.4(41.3) [D] cm
-------------	---

**Weight**

Unpacked	16.98 lbs. (7.7 kg)
----------	---------------------

**Pin assignments****VGA Cable**

The Y-shaped VGA cable that shipped with your LitePro has three connectors, they are labeled “Monitor,” “VGA,” and “LCD.” The pin assignments for these connectors are listed here.

**“LCD” Connector**

The end of the VGA cable that plugs into the LitePro is a male 26-pin D-style connector. The table below lists its pin assignments.

Input Pin	Signal Description	Output Pin
1	Vertical sync	10
2	Horizontal sync	11
8	Blue analog	14
6	Intensity digital	12
7	Green digital	13
9	Red analog	15
16	Blue digital	3
17	Red digital	4
18	Green analog input with composite sync	5

Input Pin	Signal Description	Output Pin
20	GND	
21	GND	
22	GND	
23	Digital/analog video cable ID	
24	GND	
25	VGA/no video cable ID pin	
26	Monochrome digital (Hercules)	19

### Monitor" and "VGA" Connectors

The pin assignments are the same for the "Monitor" and "VGA" connectors. The "Monitor" connector is a female video RGB, 15-pin micro-D-style connector. The "VGA" connector is a male video RGB, 15-pin micro-D-style connector. The table below lists the pin assignments for both connectors.

Pin	Signal Description
1	Red analog input
2	Green analog input with composite sync
3	Blue analog input
4	GND
5	GND
6	Red GND
7	Green GND
8	Blue GND
9	NC
10	Sync GND
11	GND
12	NC
13	Horizontal sync/composite sync input
14	Vertical sync input
15	NC

## Order information

The following In Focus products, used with the LitePro 580, can be ordered from your In Focus dealer.

<b>Standard Accessories (ship with LitePro)</b>	<b>Part Number</b>
LitePro 580 User's Guide	010-0097-xx
Lens cover	340-0182-xx
VGA cable	210-0014-xx
Mac adapter for VGA cable	516-0003-xx
A/V cable	210-0053-xx
Projection lamp	232-0059-xx
Fan intake filter	321-0044-xx
Fan intake cover	321-0042-xx
Projector connection ports cover	340-0180-xx
Projector control panel cover	340-0181-xx
LP Utilities kit	599-0076-xx
Fuse, 6.3A. 250 V.T. 5x20mm	749-0018-xx
<b>Power Cords (one ships with LitePro)</b>	
North American Power Cord	210-0023-xx
Australian Power Cord	210-0027-xx
UK Power Cord	210-0028-xx
European Power Cord	210-0029-xx
Danish Power Cord	210-0030-xx
Swiss Power Cord	210-0031-xx
<b>Optional Accessories</b>	
Travel case	591-0162-xx
Remote control cable	210-0070-xx
CGA/EGA cable	210-0032-xx
60" polarized screen	591-0149-xx

## Laptop display activation chart

The LitePro connects to a laptop computer through the computer's external monitor port. Most laptop computers do not automatically activate this port when a device such as the LitePro is connected. The following chart lists the commands that activate the external monitor port for a variety of computers. If your computer is not listed here, refer to your computer's documentation.

Computer	Key command to activate port	Key command to de-activate port
Acer	Ctrl-Alt-Esc (for setup)<	Ctrl-Alt-Esc (for setup)
AST	FN-D or Ctrl-D Ctrl-FN-D FN-F5 type from A:/IVGA/CRT	FN-D or Ctrl-D Ctrl-FN-D FN-F5 type from A:/IVGA/CRT
Austin	Ctrl-Alt-,	Ctrl-Alt-,
Altima*	Shift-Ctrl-Alt-C setup VGA/Conf.Simulscan	Shift-Ctrl-Alt-L setup VGA/Conf.Simulscan
Amrel* **	setup menu Shift-Ctrl-D	setup menu Shift-Ctrl-D
BCC	automatic - no activation command needed	reboot computer
Bondwell	LCD or CRT option	LCD or CRT option
Chaplet**	setup screen	setup screen
Commax	Ctrl-Alt-#6	Ctrl-Alt-#5
Compaq**	Ctrl-Alt-< FN-F4	Ctrl-Alt-> FN-F4
Data General	Ctrl-Alt-Command	Ctrl-Alt-Command
Data General Walkabout	2 CRT/X at DOS prompt	reboot
Datavue	Ctrl-Shift-M	Ctrl-Shift-M
Dell*	Ctrl-Alt-< Ctrl-Alt-F10	Ctrl-Alt-> Ctrl-Alt-F10
Digital	automatic FN-F2	reboot FN-F2
Dolch	dip switch to CRT	dip switch to LCD
Epson	dip switch to CRT	dip switch to LCD

<b>Computer</b>	<b>Key command to activate port</b>	<b>Key command to de-activate port</b>
Everex**	setup screen option	setup screen option
For-A	Ctrl-Alt-Shift-C	Ctrl-Shift-Alt-L
Gateway 2000	FN-F1	FN-F1
Grid* **	FN-F2, choose auto or simultaneous	FN-F2
	Ctrl-Alt-Tab	Ctrl-Alt-Tab
Hyundai	setup screen option	setup screen option
IBM 970	automatic	warm reboot
IBM ThinkPad	setup screen option	setup screen option
Kris Tech**	FN-F8	FN-F8
Mac Portable	no video port: not compatible	
Mac PowerBook		
140, 145, 170	no video port: requires a 3rd-party interface	
160, 165, 180, 250	automatic: use Set Mirroring option	warm reboot
230	requires Apple Docking Station	
Mastersport	FN-F2	FN-F1
Micro Express	automatic	warm reboot
Microslave	automatic	warm reboot
Mitsubishi	SW2 On-Off-Off-Off	SW2 Off-On-On-On
NCR	setup screen option	setup screen option
NEC*	setup screen option CRT at the DOS prompt	setup screen option LCD at the DOS prompt
Packard Bell*	FN-F2 Ctrl-Alt-<	FN-F2 Ctrl-Alt->
Panasonic	FN-F2	FN-F2
Samsung	setup screen option	setup screen option
Sanyo	setup screen option	setup screen option
Sharp	dip switch to CRT	dip switch to LCD
SPARC-Dataview	Ctrl-Shift-M	Ctrl-Shift-M
Tandy* **	Ctrl-Alt-Insert setup screen option	Ctrl-Alt-Insert setup screen option
Texas Instruments	setup screen option	setup screen option
Top-Link* **	setup screen option FN-F6	setup screen option FN-F6

Computer	Key command to activate port	Key command to de-activate port
Toshiba* **	Ctrl-Alt-End FN-End	Ctrl-Alt-Home FN-Home
4500	FN-F5 setup screen option	FN-F5 setup screen option
Wyse	software driver	software driver
Zenith	FN-F10	FN-F10

\* *These manufacturers have other models that automatically send video to the external CRT port when some type of display device is attached.*

\*\* *These manufacturers offer more than one key command depending on the computer model.*



# ▼ Index

## A

- adapters
  - Macintosh, for LitePro 2, 5
  - Macintosh, for LP Utilities 2, 5
- Adjust, remote button 22, 24, 25
- Audio menu 29
- Audio Source, menu item 29
- audio/video cable 2, 15

## B

- Backgnd, menu item 30
- background pattern 30
- balance
  - adjusting 29
  - menu item 29
- bass boost, *See Loudness*
- Bass, menu item 29
- batteries, replacing 52
- blank screen 28, 31
- Blank to, menu item 28
- Blank, menu item 31
- Blue, menu item 26
- Bright
  - control panel button 23
  - remote button 23
- Brightness, menu item 26, 27
- broadcast video
  - NTSC 61
  - PAL 61
  - SECAM 62
- buttons
  - on projector, function 23
  - on remote, function 23

## C

- cables
  - audio/video 2, 5, 15
  - LitePro 2, 5, 9
  - pin assignments for VGA cable 64
  - power 2, 5, 7
  - serial 2, 5, 33
  - supplied with the projector 5
  - S-Video 14, 61
  - VGA 2, 5, 9
- Color, menu item 27
- color, not displayed correctly 56
- compatibility
  - IBM compatible 4, 61
  - Macintosh 4, 61
- Computer menu 26
- computer video, definition 62
- connecting a computer
  - for LP Utilities 33
  - IBM-compatible desktop 10
  - IBM-compatible laptop 12
  - Macintosh desktop 11
  - Macintosh PowerBook 13
- connecting an external sound system 16
- connecting the remote control 17
- connecting video equipment 14
- Contrast, menu item 26, 27
- control panel button
  - Bright 23
  - Freeze 23
  - Function Adjust 24
  - Function Select 24
  - Menu 24
  - Menu Select 24
  - Mute 23
  - Standby 23
  - Sync 23
  - Video 23
  - Volume 23
- Custom menu 31
- Custom, remote button 23

## D

- Display menu 28
- display mode
  - controls 23
  - description 21
- displaying source of input 31
- Dly on, menu item 30

## E

- elevator foot 19
- external monitor port 67
- external speakers
  - connecting 16
  - using Fade 29

## F

- Fade, menu item 16, 29
- flipping the image
  - horizontally 28
  - vertically 28
- focus ring 18
- focusing the image 18
- Freeze
  - control panel button 23
  - remote button 23
- Function Adjust, control panel button 24, 25
- Function Select, control panel button 24, 25
- fuse, replacing 53

## G

- Green, menu item 26

## H

- Horiz, menu item 28
- horizontal display, adjusting 28

## I

- IBM-compatible computers
  - compatibility 4
  - connecting desktop models 10
  - connecting laptops 12

## image

- blurred 56
- dim 58
- fuzzy vertical bars 58
- has spots 58
- not bright 58
- not centered 56
- not displayed on computer screen 57
- not projected 56
- out of focus 56
- poor color 56
- reversed left to right 58
- shows only test pattern 57
- too wide or too narrow 57
- image size, changing 8
- Invert, menu item 28

## L

- lamp monitor 60
- lamp, replacing 50
- Language, menu item 30
- laptop computers
  - activate projector's display 67
  - compatibility 4
  - connecting 12
- lens, cleaning 47
- Light, remote button 23
- Loudness, menu item 29
- LP Remote Programmer
  - activating a template 46
  - description 33, 43
  - editing a template 44
  - keystroke code 45
  - mouse clicks 45, 46
  - programming buttons 43
  - recording a macro 44
  - typing a macro 45
  - verifying a template 46
  - ways to assign keystrokes 44
- LP Utilities 31
  - connecting your computer 33
  - description 33
  - enabling 30
  - installing software 34
  - LP Remote Programmer 43
  - LP-Link 35
  - using 33

**LP-Link**

- adjusting Audio settings 39
- adjusting Computer settings 37
- adjusting Custom settings 42
- adjusting Display settings 40
- adjusting Options settings 41
- adjusting Video settings 38
- adjustment 35, 37–42
- control panel 35
- description 33

**M**

Mac LC, menu item 26

Macintosh computers

- compatibility 4
- connecting desktop models 11
- connecting PowerBooks 13
- projected image has fuzzy vertical lines 26, 58

Menu

- control panel button 24, 25
- display position 28
- menu item 28
- remote button 24, 25

menu item

- Audio Source 29
- Backgnd 30
- Balance 29
- Bass 29
- Blank 31
- Blank to 28
- Blue 26
- Brightness 26, 27
- Color 27
- Contrast 26, 27
- Dly on 30
- Fade 29
- Green 26
- Horiz 28
- Invert 28
- Language 30
- Loudness 29
- Mac LC 26
- Menu 28
- Mode 27
- Pattern 31
- Power Save 30
- Prompt 30, 31
- Rear Proj 28

Red 26

- Reset 26, 27, 28, 29, 31
- Reset ALL 30
- Serial 30, 31
- Sharpness 27
- Source 26, 27, 28, 29, 30, 31
- Sync 26
- Text 26
- Tint 27
- Tracking 26
- Treble 29
- Upside down 28
- Vert 28
- Video Mode 27
- Volume 29

menu mode

- controls 24
- description 21
- entering 25
- exiting 25
- using the menus 25

menu mode functions 24

Menu Select

- control panel button 24, 25
- remote button 25

Mode, menu item 27

monitor lights 59

Mute

- control panel button 23
- remote button 23

**N**

NTSC 14, 27, 61

**O**

operation monitor 60

Options menu 29, 30

**P**

PAL 14, 27, 61

Pattern, menu item 31

power cable 2, 7

Power Save, menu item 30

PowerBooks

- connecting 13
- external monitor activation commands 68

projection lamp, replacing 50

projector

- accessories 66
- adjusting 18
- control panel 21
- doesn't turn on 56
- fuse 53
- maintenance 47
- monitor lights 59
- operating 21
- positioning 8
- shipping contents 2
- specifications 63
- turning off 20
- turning off temporarily 20
- turning on 18

Prompt, menu item 30, 31

**R**

- Rear Proj, menu item 28
- rear projection 28, 58
- Red, menu item 26
- Reference to menu functions 26–31

remote button

- Adjust 22, 24
- Bright 23
- Custom 23
- Freeze 23
- Light 23
- Menu 24
- Mute 23
- Select 24
- Standby 23
- Sync 23
- Trackball 24
- Video 23
- Volume 23

remote control

- batteries 52
- connecting with a cable 17, 22
- not working 58
- programming 33
- range 22
- trackball 22
- use of 22

Reset ALL, menu item 30

Reset, menu item 26, 27, 28, 29, 31

reversing colors 28

**S**

- safety guidelines iii–iv
- SECAM 14, 27, 61
- Select, remote button 24
- Serial, menu item 30, 31
- Sharpness, menu item 27
- software installation 34
- sound, not playing 57
- Source, menu item 26, 27, 28, 29, 30, 31
- Standby
  - control panel button 23
  - remote button 23
- standby mode 30
- S-Video 14, 61
- Sync
  - control panel button 23
  - menu item 26
  - remote button 23
- synchronization 23, 26, 58

**T**

- technical support
  - before calling 55
  - Europe 6
  - USA 6
- temperature monitor 59
- test pattern 31, 57
- Text, menu item 26
- Tint, menu item 27
- trackball, on remote control 22, 25
- Trackball, remote 24
- tracking
  - adjusting 26, 58
  - menu item 26
- Treble, menu item 29
- troubleshooting 55

**U**

Upside down, menu item 28

## V

Vert, menu item 28

vertical display, adjusting 28

VGA cable

attaching Mac adapter 11, 13

connecting to LitePro 10–13

pin assignments 64

Video

control panel button 23

menu 27

remote button 23

video equipment, connecting 5, 14

Video Mode, menu item 27

Volume

adjusting 29

control panel button 23

menu item 29

remote button 23

## Z

zoom lens 18

## **LIMITED WARRANTY**

In Focus Systems Inc. ("In Focus") warrants that each LitePro 580 ("the Product") sold hereunder will conform to and function in accordance with the written specifications of In Focus. Said limited warranty shall apply only to the first person or entity that purchases the Product for personal or business use and not for the purpose of distribution or resale. Said warranty shall continue for a period of one (1) year from the date of such purchase. In Focus does not warrant that the Product will meet the specific requirements of the first person or entity that purchases the Product for personal or business use. In Focus' liability for the breach of the foregoing limited warranty is limited to the repair or replacement of the Product or refund of the purchase price of the Product, at In Focus' sole option. To exercise the Purchaser's rights under the foregoing warranty, the Product must be returned at the Purchaser's sole cost and expense, to In Focus or to any authorized In Focus service center provided, however, that the Product must be accompanied by a written letter explaining the problem and which includes (i) proof of date of purchase; (ii) the dealer's name; and (iii) the model and serial number of the Product. A return authorization number, issued by the In Focus customer service department, must also be clearly displayed on the outside of the shipping carton containing the Product.

## **WARRANTY LIMITATION AND EXCLUSION**

In Focus shall have no further obligation under the foregoing limited warranty if the Product has been damaged due to abuse, misuse, neglect, accident, unusual physical or electrical stress, unauthorized modifications, tampering, alterations, or service other than by In Focus or its authorized agents, causes other than from ordinary use or failure to properly use the Product in the application for which said Product is intended.

## **DISCLAIMER OR UNSTATED WARRANTIES**

THE WARRANTY PRINTED ABOVE IS THE ONLY WARRANTY APPLICABLE TO THIS PURCHASE. ALL OTHER WARRANTIES, EXPRESS OR IMPLIED, INCLUDING, BUT NOT LIMITED TO, THE IMPLIED WARRANTIES OF MERCHANTABILITY AND FITNESS FOR A PARTICULAR PURPOSE ARE DISCLAIMED. THERE ARE NO WARRANTIES THAT EXTEND BEYOND THE FACE HEREOF AND THE FOREGOING WARRANTY SHALL NOT BE EXTENDED, ALTERED OR VARIED EXCEPT BY WRITTEN INSTRUMENT SIGNED BY IN FOCUS.

## **LIMITATION OF LIABILITY**

IT IS UNDERSTOOD AND AGREED THAT IN FOCUS' LIABILITY WHETHER IN CONTRACT, IN TORT, UNDER ANY WARRANTY, IN NEGLIGENCE OR OTHERWISE SHALL NOT EXCEED THE RETURN OF THE AMOUNT OF THE PURCHASE PRICE PAID BY PURCHASER AND UNDER NO CIRCUMSTANCES SHALL IN FOCUS BE LIABLE FOR SPECIAL, INDIRECT OR CONSEQUENTIAL DAMAGES. THE PRICE STATED FOR THE PRODUCT IS A CONSIDERATION IN LIMITING IN FOCUS' LIABILITY. NO ACTION, REGARDLESS OF FORM, ARISING OUT OF THE AGREEMENT TO PURCHASE THE PRODUCT MAY BE BROUGHT BY PURCHASER MORE THAN ONE YEAR AFTER THE CAUSE OF ACTION HAS ACCRUED.

**Part Number 010-0097-01**