

# *Cinema***TEN'80**



**Native resolution of 1920x1080**  
**Rainbow-free 3 chip engine**  
**Finest D-ILA technology**

**1080p**  
Full HD

  
3 chip

**D-ILA®**

*DreamVision*  
WE MAKE THE WORLD DREAM

We are proud to announce our latest full HD projector. The *CinemaTEN'80* offers an outstanding film like quality picture never reached before with digital technology.

The *CinemaTEN'80* uses the ultimate optronical technology associated with high precision optical elements to offer a pure and harmonious picture.

**The latest L-COS technology**

The CinemaTEN'80 delivers an unbelievable film like picture by using the most advanced technology : the Digital Direct Drive Image Light Amplifier (D-ILA) technology. Our 3-chip projector is based on 1920x1080 native resolution, 0,82" D-ILA chips that deliver the purest picture ever.



**Clear crystal picture**

The D-ILA's innovative CMOS design performs a punchy and detailed picture. Achieving an exceptional 93% fill factor, the CinemaTEN'80 eliminates the annoying "grid" or "screen door effect".

The color reproduction is achieved in the three D-ILA matrix by reflecting the exact amount of light intensity in natural gradations. The result is an extremely smooth and stable picture without flicker even in deep black.

Fill Factor	
LCD	40% - 60%
DLP	80% - 90%
D-ILA	93% - 95%
CRT (analogic)	100%

**Post-production D65 calibration**

The optical engine produces rich and natural colors with smooth gradations. The color temperature is set at the D65 standard which is the home theater standard. This makes all color gradations natural and consistent, including deep black and absolute white.

**Easy calibration**

The special calibration software provides a low level calibration that controls within a friendly graphic interface every parameter of the color management.

Already calibrated at D65 standard, the CinemaTEN'80 requires minor changes to match perfectly every systems.

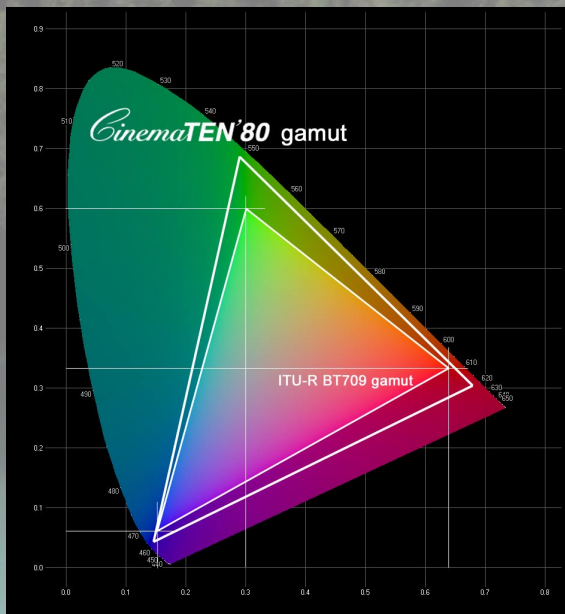

The color reproduction of the CinemaTEN'80 exceeds the HDTV standards.

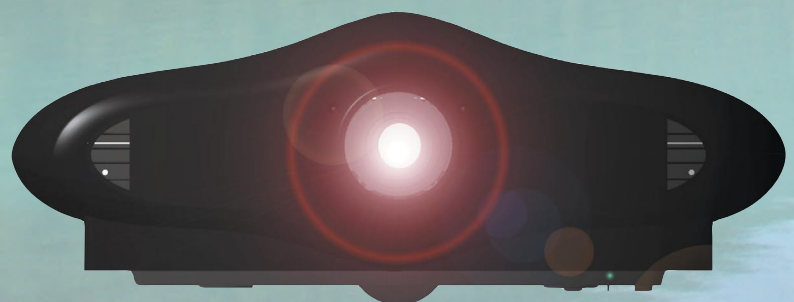

### High precision optics.

The CinemaTEN'80 is equipped with a high-precision lens specially designed in full-glass elements to match the extreme high resolution and 12 bits color rendering. They feature an optical offset up to 60% vertically with no visible picture distortion.

The ColorQuad™ technology that uses a complex prismatic system to split the light into three primary color beams. The Color Select™ filters have been carefully selected to obtain a high temperature white and a wide gamut response that exceeds the HDTV standards.

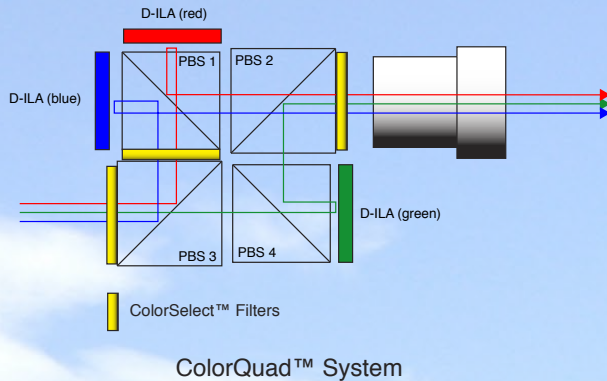

### Enjoy your every source in Full HD resolution with the DreamScaler 2.

The ultimate performances are achieved by using the DreamScaler 2. With its 12 available video inputs and 9 audio inputs, you have enough room to connect every multimedia source as DVD-player, HD-DVD source, satellite receiver or multimedia computer.

The DreamScaler 2 features not only a video hub with a user-friendly routing interface, but also an exceptional video processing that optimizes your films and programs into full HD resolution. The result is an extremely smooth and detailed picture.

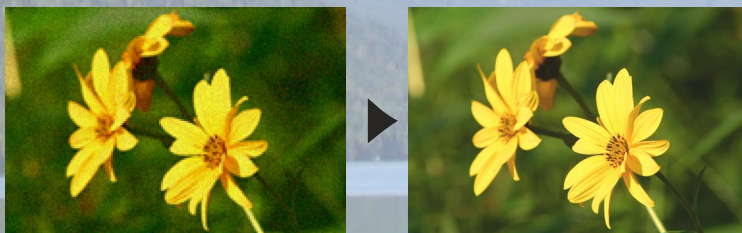

The DreamScaler2 is a 10-bit video processor that uses Precision Video Scaling™ technology and AutoCUE-C™ correction powered by Anchor Bay Technologies, Inc.

### Easiest installation ever

- Short Throw and Long Throw options.
- Electronic Zoom and focus.
- Optical shift from 0% to 60% vertical offset.
- Compact projector, light weight of 18 Kg.
- Color calibration at D65 standard.
- Superb design.



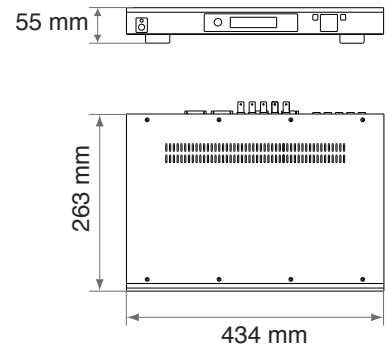
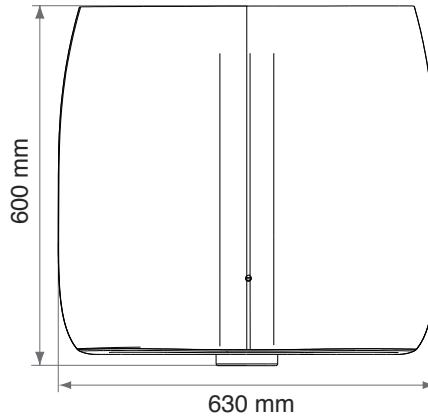
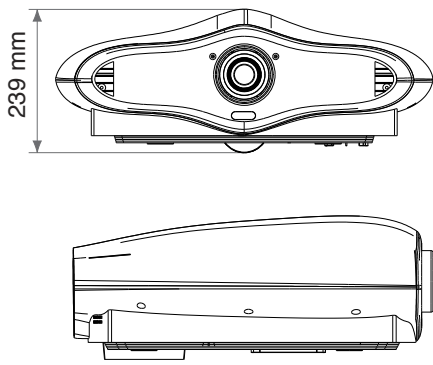

## CinemaTEN'80

### Light engine

D-ILA Technology	3x 0.82" panels (using reflective Liquid Crystal On Substrate - LCOS technology)
Aspect Ratio	16:9
Native Resolution	Full HD - 1920 x 1080 pixels
Projection Lens	Short Throw 1.5:1 - 2.1:1 (with motorized zoom and focus) Long Throw 2.0:1 - 3.8:1
Optical Shift	0-60% vertical offset
Light source	200 W NUP lamp - 2,000 hours lifetime

### Characteristics

Screen range	Short Throw 50-300 inches diagonal Long Throw 50-250 inches diagonal
Brightness	800 ANSI lumens
Contrast	3500:1
Colorimetry	standard D65 pre-calibration

### Connectivity

Inputs	1x DVI-D , HDCP capable 1x RS-232C 1x 3.5mm mini-jack (Service only)
Output	1x 3.5mm mini-jack 12V Screen Trigger

### Power and Mechanical Characteristics

Noise level	27 dB
Power Consumption	320W (5W in standby mode)
Power Supply	AC100-240V 50/60Hz
Dimensions (WxHxD)	630 x 239 x 600 mm approx
Net Weight	17,0 kg

## DreamScaler 2

### Inputs

Video	4x HDMI , 2x S-video, 2x Composite Video, 2x Component, 1x RGBHV/Component, 1x SD-SDI (optional)
Audio	4x HDMI, 2x Coaxial Digital, 2x Optical Digital, 1x Analog stereo L/R

### Outputs

1x Digital HDMI , 1x Analog Video 5-BNC, 1x Coaxial Digital audio, 1x Optical Digital audio

### Power and Mechanical Characteristics

Power Consumption	< 30W
Power Supply	AC100-240V 50/60Hz
Dimensions (WxHxD)	434 x 55 x 263 mm with feet
Net Weight	2,9 kg

### Contact information

TEC - DreamVision  
7, rue La Caille, 75017 Paris, France  
Tel +33 1 42 29 44 44  
E-mail sales@dreamvision.net  
www.dreamvision.net

Ref.no.DRAFT12 - Sept '06

*DreamVision*

WE MAKE THE WORLD DREAM