

CP-S420

Specifications		
Model name	CP-S420	
Liquid crystal panel structure	0.9" polysilicon active-matrix TFT x 3	
Number of pixels	480,000 pixels (V600 x H800)	
Resolution	800 x 600 color pixels	
Frequency	f _H [kHz]	15~91
	f _V [Hz]	50~120
Lens	Manual zoom (F=1.7-2.1) 1 : 1.3 Manual focus	
Lamp	250W UHB	
Brightness	2,700 ANSI Lumens	
Speakers	1W + 1W (stereo)	
Power supply	AC100-120V/AC220-240V	
Power consumption	410W	
Operating temperature	0-35°C (32-95°F)	
Input signals	RGB input	VGA, SVGA, XGA, SXGA, UXGA, MAC13", MAC16"
	Video input	NTSC, NTSC4.43, PAL, PAL60, SECAM, M-PAL, N-PAL, HDTV: 750p (720p), 1125i (1080i/1035i) SDTV: 525i (480i), 525p (480p), 625i (575i)
Input/output terminals	Video input	S-Video: Mini DIN 4-pin terminal x 1 Composite video: RCA jack terminal x 1 Component video: RCA jack terminal x 3 Audio: RCA jack terminal x 2 (L/R)
	RGB input	Analog RGB: D-sub 15-pin shrink terminal x 2 Audio: Stereo mini jack x 2
	Output	Analog RGB: D-sub 15-pin shrink terminal x 1 Audio: Stereo mini jack x 1
	Control terminal	D-sub 15-pin shrink terminal x 1
Regulatory (Agency, Safety, EMI/RFI)	UL/cUL UL60950, CSA60950, FCC-Part 15, class B, CE approval, EN61000-3-2, EN61000-3-3, EN55022, EN55024, TUV EN60950, Low voltage directive	
Dimensions (WxHxD)	360 x 106 x 256.5mm (14-3/16" x 4-3/16" x 10-1/8") [excl. protruding part]	
Weight	4.5kg (9 lbs. 14 oz.)	
Standard accessories	Remote controller, Video/audio cable, Power cord, Component cable, PS/2 mouse cable, Batteries LR6, RGB cable	

•Design and specifications are subject to change without notice.
 •The comparison photos in this catalog are simulations.
 •LCD panels, polarizers and other optical components and cooling fans may need replacement after prolonged usage.
 For more details, please consult the Hitachi sales representative listed below.

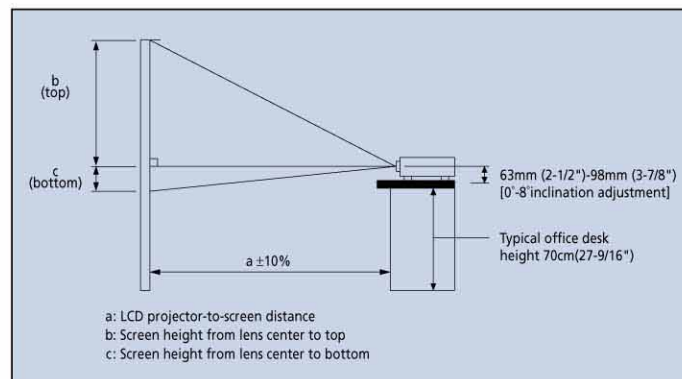

Screen Size (inch)	a Min	a Max	b (top)	c (bottom)
30	1.2m (45.3")	1.5m (60.9")	44cm (17")	2cm (1")
40	1.6m (61.7")	2.1m (81.5")	58cm (23")	3cm (1")
60	2.4m (94.3")	3.1m (122.7")	87cm (34")	4cm (2")
70	2.8m (110.7")	3.6m (143.4")	102cm (40")	5cm (2")
80	3.2m (127.0")	4.2m (164.0")	116cm (46")	6cm (2")
100	4.1m (159.7")	5.2m (205.2")	145cm (57")	7cm (3")
120	4.9m (192.4")	6.3m (246.4")	174cm (69")	9cm (4")
150	6.1m (241.4")	7.8m (308.3")	218cm (86")	11cm (4")
200	8.2m (323.1")	10.4m (411.3")	290cm (114")	15cm (6")
300	12.4m (486.4")	15.7m (617.5")	435cm (171")	22cm (9")

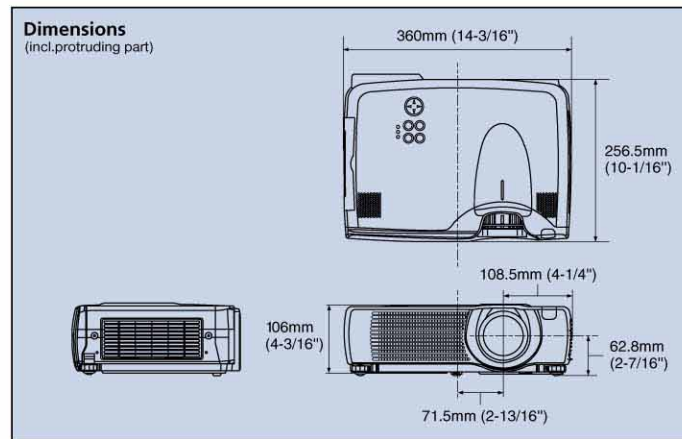

Hitachi, Ltd. Digital Media Division (Yokohama Plant) has received ISO 14001 certification.



MULTIMEDIA PROJECTOR CP-S420

HITACHI Inspire the Next



2,700 ANSI Lumens 4.5kg (9 lbs. 14 oz.)

Bright, quiet and convenient — the projector you can rely on anywhere.

HITACHI

Hitachi Europe Ltd.
 Whitebrook Park, Lower Cookham Road, Maidenhead, Berkshire, SL6 8YA, UK
 Tel: +44-1628-643000 Fax: +44-1628-643404 www.hitachidigitalmedia.com

Hitachi America, Ltd. Digital Media Division
 Hitachi Plaza 2000 Sierra Point Parkway, Brisbane, CA 94005-1835, U.S.A.
 Tel: +1-800-HITACHI Fax: +1-650-244-7776 www.hitachi.us/digitalmedia

Hitachi Canada Ltd.
 6740 Campobello Road, Mississauga, Ontario L5N2L8, Canada
 Tel: +1-905-821-4545 Fax: +1-905-821-1011 www.hitachi.ca

Hitachi Home Electronics Asia (S) Pte. Ltd.
 16 Collyer Quay #31-00 Hitachi Tower, Singapore 049318
 Tel: +65-6536-2520 Fax: +65-6536-2521 www.hitachimultimedia.com.sg

Hitachi Sales (Malaysia) Sdn. Bhd.
 Wisma Hitachi, No.2, Lorong 13/6A, 46200 Petaling Jaya, Selangor Darul Ehsan, Malaysia
 Tel: +60-3-79573455 Fax: +60-3-79556090

Hitachi Sales (Thailand), Ltd.
 994, 996 Soi Thonglor, Sukhumvit 55 Road, Klongton, Klongtoey, Bangkok 10110, Thailand
 Tel: +66-2-381-8381 Fax: +66-2-381-9520

Hitachi (Hong Kong), Ltd.
 18th Floor, Ever Gain Centre, 28 On Muk Street, Shatin, N.T., Hong Kong
 Tel: +852-2113-8883 Fax: +852-2780-4178 www.hitachi-multimedia.com.hk

Hitachi Sales Corp. of Taiwan
 2nd Floor, No.65, Nanking East Road, Section 3, Taipei, Taiwan
 Tel: +886-2-2516-0500 Fax: +886-2-2516-1501

Hitachi Australia Ltd.
 Level 3, 82 Waterloo Road, North Ryde, NSW 2113, Australia
 Tel: +61-2-9888-4100 Fax: +61-2-9888-4188 www.hitachi.com.au

Outstanding brightness and image quality, with advanced functions for easier use in all types of situations.



An amazing 2,700 ANSI Lumens and rounded, compact body (4.5 kg/9 lbs. 14 oz.).

By increasing the aperture ratio of the three 0.9" polysilicon active matrix TFT panels and by upgrading the UHB lamp to 250W, Hitachi has achieved high brightness of 2,700 ANSI Lumens. As a result, the CP-S420 will project images that are clear and easy to see, even in a bright room. Even with this excellent performance, the projector is very light at 4.5 kg (9 lbs. 14 oz.).

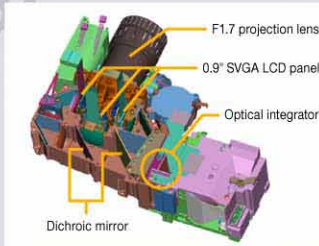

New functions for smoother presentations. Vertical and Horizontal Keystone Correction

The CP-S420's Keystone Correction function can correct for two types of keystone distortion. Vertical, caused by height differences between the screen and the projector, and horizontal, caused by the left-right displacement that occurs when the projector cannot be placed in front of the screen. It is thus ideal for use in rooms where space is limited. In addition to adjustment via the remote control, there is a Keystone button on the projector as well for added convenience.

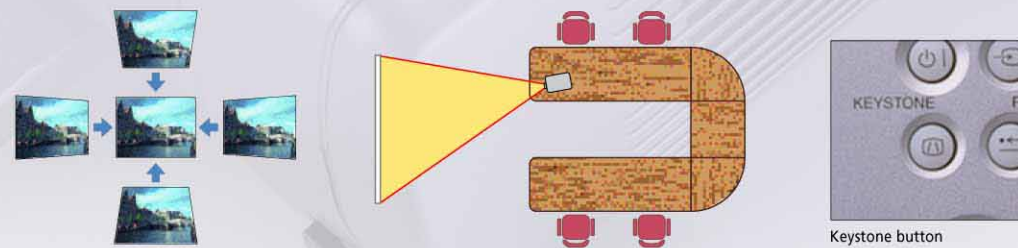

My Screen

You can select any image you want for the first image and when the screen would otherwise be blank. For example, your company's logo.



Normal first image



Now you can use your company logo or a title for the first image.

MULTIMEDIA PROJECTOR CP-S420



Quieter and clearer. Full video system functions.

36dB Whisper Mode lowers annoying fan noise

The extra-quiet Whisper Mode controls annoying noise by efficiently exhausting the lamp's heat. It's perfect for use in rooms with low illumination where low noise is more important than brightness.

* Standard mode: 40dB. Whisper mode: 2,160 ANSI Lumens.



3 Gamma Correction Modes

In addition to the Normal Mode, you can choose the Cinema Mode, which improves the clarity of subtle black gradations for watching dark movie scenes, or the Dynamic Mode, which clearly reproduces areas with varying contrast and is effective during conferences or presentations in bright rooms.

16:9, 4:3, and small 4:3 aspect ratio compatibility

The height of 16:9 and small 4:3 images can be adjusted in three steps. And there is no danger of the image being divided between top and bottom when projecting small 4:3 on a 16:9 screen hung from the ceiling.



3RGB and 3 video terminal provided for simultaneous input

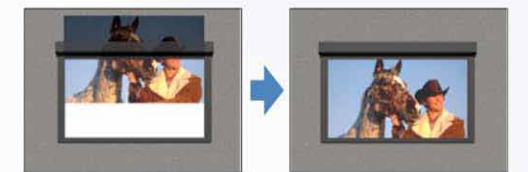
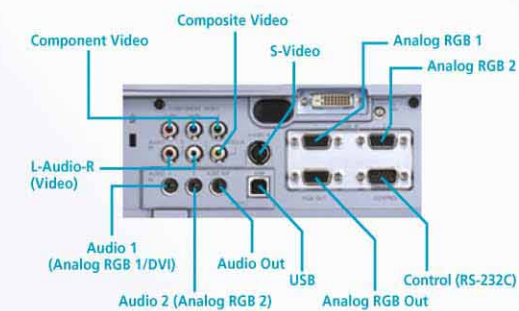

Image is too high on the screen. You can adjust the position with the remote control.

Other features that enhance operation.

Partial Expansion

You can use this function to expand a table, drawing, or other figure in order to emphasize one part on the screen. Without decreasing image quality, you can expand from normal size to four times vertically and horizontally (area is 16x larger).



Illuminated Buttons

Illuminated operating buttons are positioned on the top of the projector, making it easier to operate in a dark room.



Freeze

This function is convenient when you do not want to show a file change or other unrelated images during a presentation, lecture, etc. You can also temporarily freeze the image during a movie.

Remote control light sensitive element is on the top

Because the light sensitive element is on the top part of the projector, it can be operated via the remote control no matter where it is, even suspended from the ceiling. There is also a light sensitive element on the rear panel, for remote control from behind the projector.



Light sensitive element on front/top Light sensitive element on rear panel