

Data Projector

Operating Instructions

Before operating the unit, please read this manual and supplied Quick Reference Manual thoroughly and retain it for future reference.

VPL-EX175/EX145/EX120/EX100

Not all models are available in all countries and area. Please check with your local Sony Authorized Dealer.

Table of Contents

Overview

Location and Function of Controls	3
Main unit	3
Connector Panel	4
Remote Commander and Control Panel	5

Preparation

Connecting the Projector	7
Connecting a Computer	7
Connecting a Video equipment	8
Connecting an External Monitor and Audio Equipment	9

Projecting/Adjusting an Image

Projecting an Image	10
Adjusting the Projected image	11
Turning Off the Power	13

Adjustments and Settings Using a Menu

Using a MENU	14
The Picture Menu	15
The Screen Menu	16
The Function Menu	18
The Operation Menu	19
The Connection/Power Menu	20
The Installation Menu	21
The Information Menu	22

Network

Using Network Features (VPL-EX145/ EX175 only)	23
Displaying the Control Window of the Projector with a Web Browser	23
Confirming the Information regarding the Projector	24
Operating the Projector from a Computer	24
Using the e-mail report Function	24

Others

Indicators	26
Messages List	27
Troubleshooting	28
Replacing the Lamp	30
Cleaning the Air Filter	32
Specifications	33
Projection Distance	38
Dimensions	41
Index	43

Location and Function of Controls

Main unit

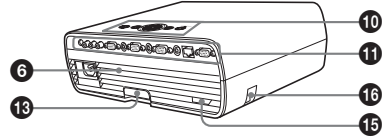
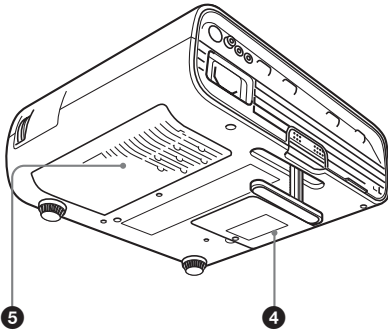
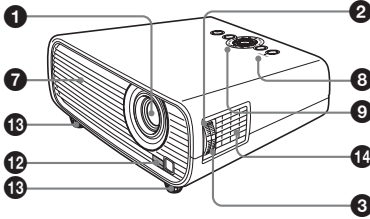

- ❶ Projection lens
- ❷ Focus ring (page 11)
- ❸ Zoom ring (page 11)
- ❹ Lamp cover (page 30)
- ❺ Air filter cover (page 32)/
Ventilation holes (intake)
- ❻ Ventilation holes (intake)
- ❼ Ventilation holes (exhaust)

Caution

Do not place anything near the ventilation holes as this may cause internal heat buildup. Do not place your hand near the ventilation holes and the circumference as this may cause injury.

- ❸ ON/STANDBY indicator (page 26)
- ❹ LAMP/COVER indicator (page 26)
- ❺ Control panel (page 5)
- ❻ Connector panel (page 4)
- ❼ Remote control detector
- ❸ Adjuster (page 11)
- ❹ Speaker (page 18)
- ❺ Security lock
Connects to an optional security cable manufactured by Kensington. For details, visit Kensington's web site. <http://www.kensington.com/>
- ❻ Security bar
Connects to a commercially available security chain or wire.

Connector Panel

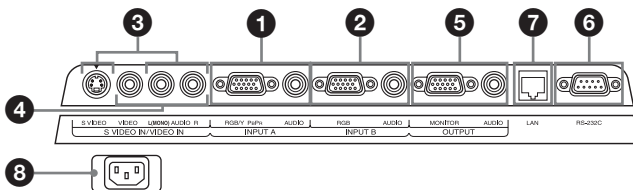

Input (pages 7, 8)

1 INPUT A

Video: RGB/YPbPr input connector (RGB/YPbPr)

Audio: Audio input connector (AUDIO)

2 INPUT B (VPL-EX120/EX145/EX175 only)

Video: RGB input connector (RGB)

Audio: Audio input connector (AUDIO)

3 S VIDEO (S VIDEO IN)

Video: S video input connector

Audio: Audio input connector (L [MONO] AUDIO/R)

4 VIDEO (VIDEO IN)

Video: Video input connector

Audio: Audio input connector (L [MONO] AUDIO/R)

Note

The audio inputs of S VIDEO and VIDEO are shared.

Output (page 9)

5 OUTPUT

Video: Monitor output connector (MONITOR)

Audio: Audio output connector (AUDIO)

Note

This connector outputs the projected image or audio. The image is output as a computer signal input from the RGB input connector (INPUT A/INPUT B (INPUT B is available only for VPL-EX120/EX145/EX175)) or a video signal input from the YPbPr input connector (INPUT A).

Others

6 RS-232C connector

RS-232C compatible control connector. Connects the computer's RS-232C connector and the RS-232C cross cables.

7 LAN connector (VPL-EX145/EX175 only) (page 23)

8 AC IN (-) socket

Connects the supplied AC power cord.

Remote Commander and Control Panel

Remote Commander

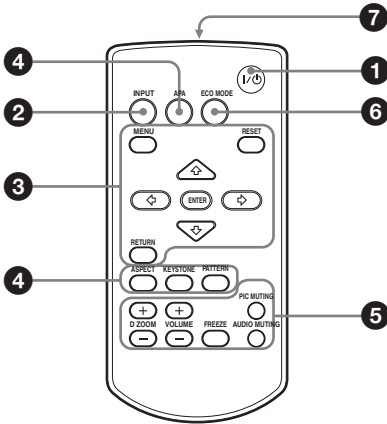

Control Panel

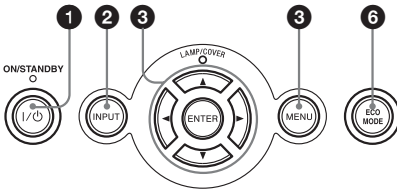

1 Turning on the power/Going to standby mode

I/O (On/Standby) key

2 Selecting an input signal (page 10)

INPUT key

3 Operating a menu (page 14)

MENU key
RESET key
ENTER /▲/▼/◀/▶ (arrow) keys
RETURN key

4 Adjusting the image (page 11)

ASPECT key
KEYSTONE key
PATTERN key
APA (Auto Pixel Alignment) key*

Note

* Use this key when inputting a computer signal via the RGB input connector (INPUT A/INPUT B (INPUT B is available only for VPL-EX120/EX145/EX175)).

5 Using various functions during projecting

D ZOOM (Digital Zoom) +/- key*1
Enlarges a portion of the image while projecting.

1 Press the D ZOOM + key to display the digital zoom icon on the projected image.

2 Press the ▲/▼/◀/▶ keys to move the digital zoom icon to the point on the image you wish to enlarge.

3 Press the D ZOOM + key or the D ZOOM – key repeatedly to change the enlargement ratio. The image can be enlarged up to 4 times.

Press the RESET key to restore the previous image.

PIC MUTING key

Cuts off the image. Press again to restore the image.

AUDIO MUTING key

Mutes the audio output. Press again to restore the previous volume.

VOLUME +/- key

For adjusting the volume output.

FREEZE key*2

Pauses a projected image. Press again to restore the image.

Notes

- *1: Use this key when inputting a computer signal. But it may not be used depending on the resolution of the input signal.
- *2: Use this key when inputting a computer signal.

6 Setting the energy-saving mode easily

ECO MODE key

Energy-saving mode can be set easily. Energy-saving mode consists of “Lamp Mode,” “Power Saving Mode” and “Standby Mode.”

- 1 Press the ECO MODE key to display the ECO Mode menu.

ECO Mode Menu

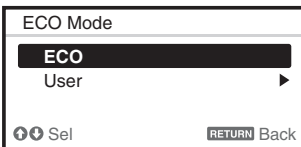

- 2 Press the \uparrow/\downarrow key or ECO MODE key to select ECO or User mode.

ECO: Sets each mode to the optimum energy-saving value.

Lamp Mode: Low

Power Saving Mode: Standby

Standby Mode: Low

(go to step 6)

User: Sets each item of the energy-saving mode menu as you desire (go to step 3).

- 3 Select “User” then press the \rightarrow key. The setting items appear.

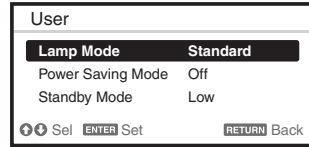

- 4 Press the \uparrow/\downarrow key to select the item then press the ENTER key.
- 5 Press the \uparrow/\downarrow key to select the setting value.
- 6 Press the ENTER key to restore the previous image.

For details on ECO Mode settings, see “Lamp Mode” (page 18) on the Function menu and “Standby Mode” (page 20) and “Power Saving Mode” (page 20) on the Connection/Power menu.

Others

7 Infrared transmitter

About Remote Commander operation

- Direct the Remote Commander toward the remote control detector.
- The shorter the distance between the Remote Commander and the projector is, the wider the angle within which the Remote Commander can control the projector becomes.
- Make sure that nothing obstructs the infrared beam between the Remote Commander and the remote control detector on the projector.

Connecting the Projector

Notes

- Make sure all the equipment is powered off when connecting the projector.
- Use the proper cables for each connection.
- Insert the cable plugs firmly; Loose connections may reduce performance of picture signals or cause a malfunction. When pulling out a cable, be sure to grip it by the plug, not the cable itself.
- For more information, refer also to the instruction manuals of the equipment you are connecting.
- Use a no-resistance audio cable.

Connecting a Computer

Connection with a computer is explained for each input signal.

INPUT A/INPUT B (INPUT B is available only for VPL-EX120/EX145/EX175)

For connecting a computer with an RGB output connector.

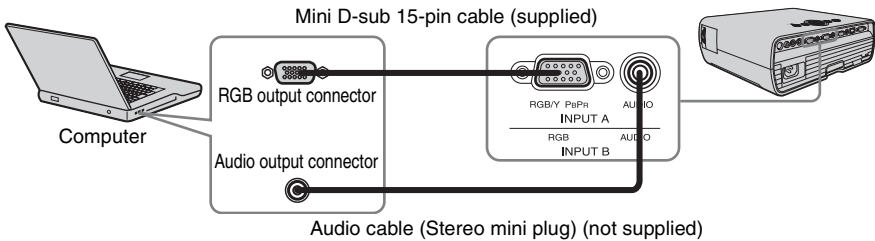

Note

- It is recommended that you set the resolution of your computer to 1024 × 768 pixels for the external monitor.

Connecting a Video equipment

Connections with a VHS video deck, DVD player, or BD player are explained for each input signal.

S VIDEO IN

For connecting video equipment with an S-video output connector.

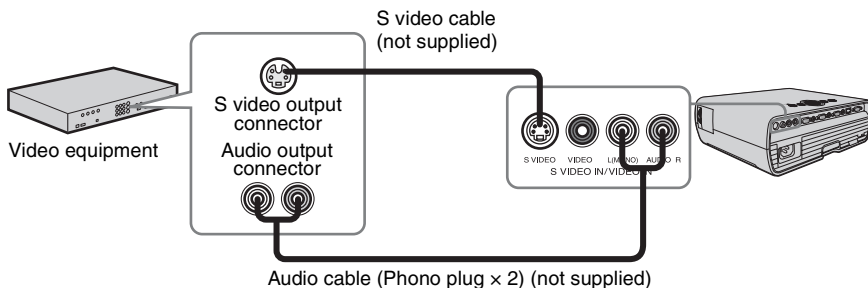

VIDEO IN

For connecting video equipment with a video output connector.

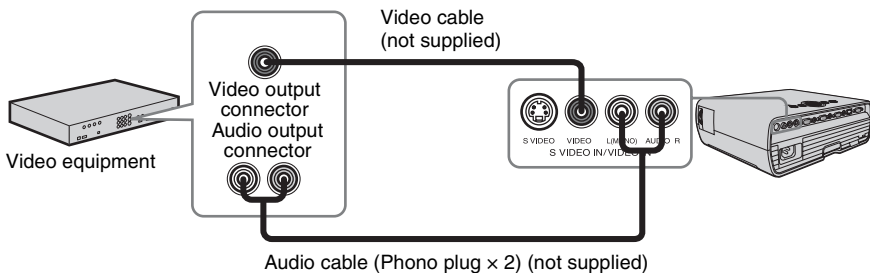

INPUT A

For connecting video equipment with a YPbPr output connector.

Component – Mini D-sub 15-pin cable (not supplied)

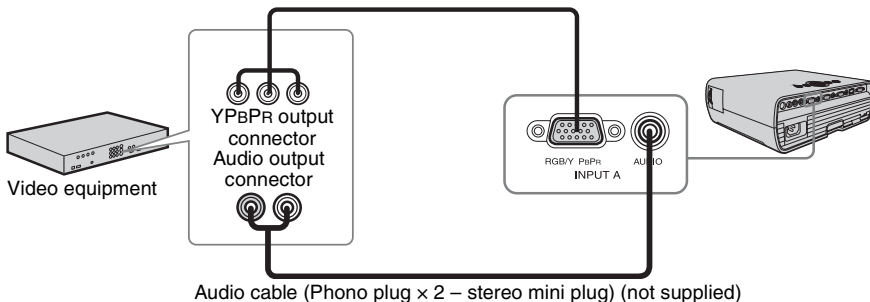

Connecting an External Monitor and Audio Equipment

OUTPUT

Projected images and input audio can be output to display equipment such as a monitor and audio equipment such as speakers with a built-in amplifier.

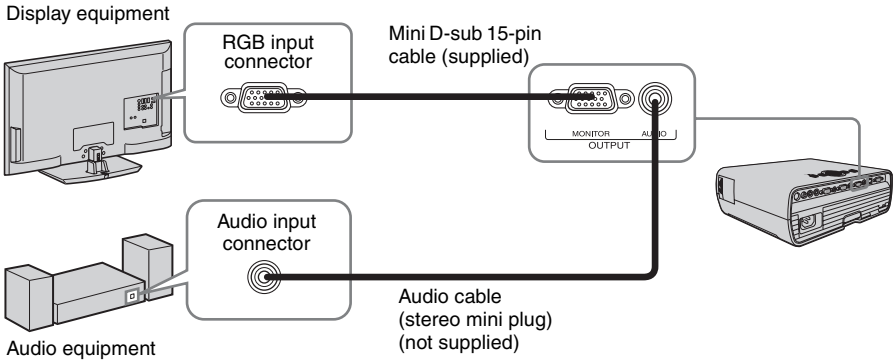

Preparation

Note

Projected images and audio can be output. The image is output only as a computer signal input from the RGB input connector (INPUT A/INPUT B (INPUT B is available only for VPL-EX120/EX145/EX175)) or a video signal input from the YPbPr input connector (INPUT A).

Projecting an Image

The size of a projected image depends on the distance between the projector and screen. Install the projector so that the projected image fits the screen size. For details on projection distances and projected image sizes, see “Projection Distance” (page 38).

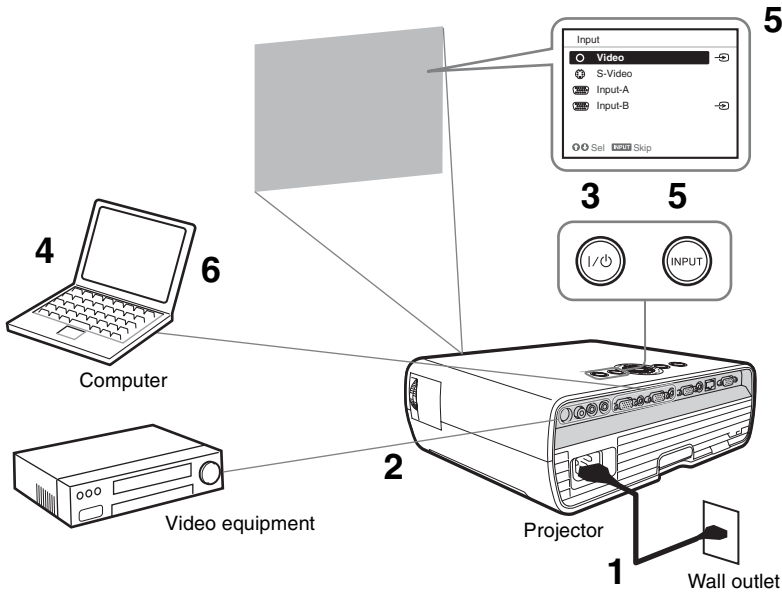

- 1** Plug the AC power cord into the wall outlet.
- 2** Connect all equipment to the projector (page 7).
- 3** Press I/⏻ to turn on the unit.
- 4** Turn on the connected equipment.
- 5** Select the input source.
Press the INPUT key on the projector to display the input select window. Press the INPUT key repeatedly or the ▲/▼ key to select an image to be projected.



- 6** Switch your computer to output to external display by changing your computer's setting.
How to switch the computer to output to the projector varies, depending on the type of computer.

(Example)

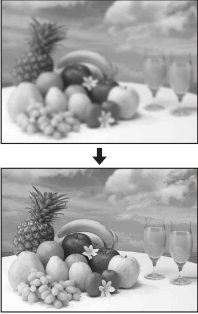

- 7** Adjust the focus, size, and position of the projected image (page 11).

Adjusting the Projected image

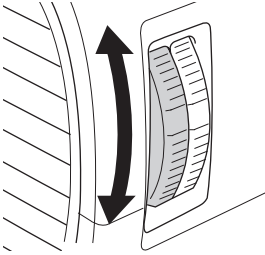
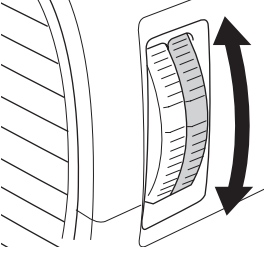
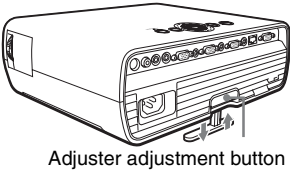
Focus	Size (Zoom)	Position
		
		 <p data-bbox="743 788 983 810">Adjuster adjustment button</p>

Adjusting the tilt of the projector with the adjusters

You can adjust the height of the projector using the adjusters. By changing the slope of the projector with adjusters, you can adjust the position of the projected image.

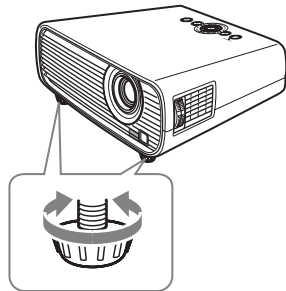

Notes

- Be careful not to let the projector down on your fingers.
- Do not push hard on the top of the projector with the adjuster extended. It may cause malfunction.

Changing the aspect ratio of the projected image

Press ASPECT on the remote commander to change the aspect ratio of the projected image. You can also change the setting in Aspect of The Screen Menu (page 16, page 17).

Correcting trapezoidal distortion of the projected image (Keystone feature)

Keystone feature may not work automatically when the screen is tilted. In this case, set keystone manually.

- 1 Press KEYSTONE on the remote commander or select V Keystone in The Installation Menu.
- 2 Use ▲/▼/◀/▶ to set the value. The higher the setting, narrower the top of the projected image. The lower the setting, the narrower the bottom.

Note

Since the Keystone adjustment is an electronic correction, the image may be deteriorated.

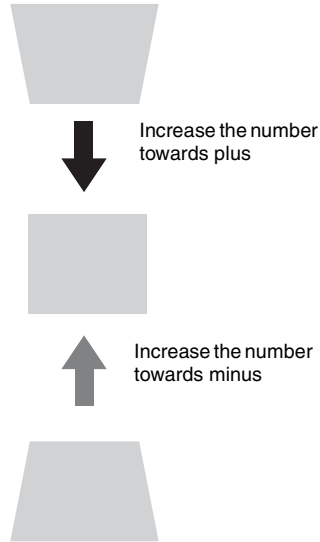

Displaying a pattern for adjusting an image

You can display a pattern for adjusting the projected image with the PATTERN key on the Remote Commander. Press the PATTERN key again to restore the previous image.

Automatically adjusts Phase, Pitch and Shift of projected image while a signal is input from a computer (APA (Auto Pixel Alignment)).

Press APA on the remote commander. Press again to cancel during the setting. You can also set APA in The Screen Menu (page 16).

If Smart APA is set to On, executes APA automatically when a signal is input (page 18).

Turning Off the Power

- 1** Press the I/⏻ key on the main unit or the Remote Commander.
The message appears. Press it again according to the message.
- 2** Unplug the AC power cord from the wall outlet.
After step **1**, the fan continues to run for a while to reduce internal heat, however, you may also unplug the AC power cord before the fan stops.

To clear the confirmation message

The message disappears if you press any key other than the I/⏻ key on the main unit or the Remote Commander, or if you do not press any key for a while.

To turn off without displaying confirmation message

Hold the I/⏻ key on the main unit or the Remote Commander pressed for a few seconds.

Using a MENU

Note

The menu displays used for the explanation below may be different depending on the model you are using.

- 1 Press the MENU key to display the menu.
- 2 Select the setting menu.
Use the **▲** or **▼** key to select the setting menu then press **▶** or ENTER key.

Setting menu

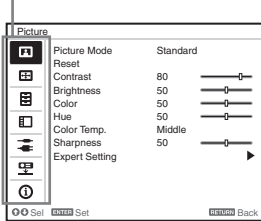

- 3 Select the setting item.
Use the **▲** or **▼** key to select the setting menu then press **▶** or ENTER key.
To return to the selection screen of the setting menu, press the **◀** key or the RETURN key.

Setting items

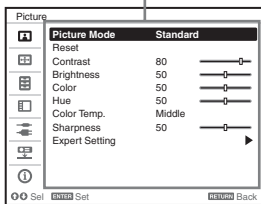

- 4 Make the setting or adjustment for the selected item.
Menu operation differs depending on the setting item. If the next menu window is displayed, select the item according to the operations in step 3.
To return to the selection screen of the setting items, press the **◀** key or the RETURN key. Also, to reset the setting

value of an item to its factory preset value, press the RESET key during setting or adjusting.

Using a pop-up menu

Press the **▲/▼/◀/▶** key to select an item. Press the ENTER key to restore the previous screen.

Selecting items

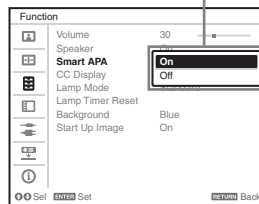

Using the setting menu

Press the **▲** or **▼** key to select the item. Press the ENTER key to restore the previous screen.

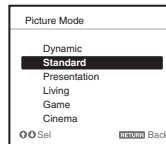

Using the adjustment menu

To increase the number, press the **▲** or **▶** key and to decrease the number, press the **▼** or **◀** key. Press the ENTER key to register the setting. The previous screen is restored.



- 5 Press the MENU key to clear the menu.

The menu disappears automatically if no key is pressed for a while.

The Picture Menu

For adjusting the picture for each input signal.

Items	Item descriptions
Picture Mode	Dynamic: Emphasizes the contrast to produce a “dynamic and vivid” picture. Standard: Makes the picture be natural and well balanced. Presentation ^{*1} : Makes the picture bright to suit for a presentation. Living: Select for viewing sports, music, and digital video camera picture. Game: Select for viewing game picture. Cinema: Select for viewing film-like picture.
Reset ^{*2}	The picture settings are initialized to their factory preset values.
Contrast	The higher the setting, the greater the contrast. The lower the setting, the lower the contrast.
Brightness	The higher the setting, the brighter the picture. The lower the setting, the darker the picture.
Color ^{*3 *5}	The higher the setting, the greater the intensity. The lower the setting, the lower the intensity.
Hue ^{*3 *5 *6}	The higher the setting, the more greenish the picture becomes. The lower the setting, the more reddish the picture becomes.
Color Temp. ^{*4}	High/Middle/Low: The higher the temperature, the more bluish the picture. The lower the temperature, the more reddish the picture.
Sharpness ^{*3}	The higher the setting, the sharper the picture. The lower the setting, the softer the picture.
Expert Setting	
Film Mode ^{*3 *7}	Auto: Precisely reproduces the image from a film source to suit the original film source. Normally, select this option. Off: Select this option if the images are rough around the edges when “Auto” is selected.
Gamma Mode ^{*1}	Graphics: Improves the reproduction of halftones. Photos can be reproduced in natural tones. Text: Contrasts black and white. Suitable for images that contain lots of text.

Notes

- *1: When a computer signal is input, this option is available.
- *2: Picture Mode setting will not be initialized to the factory preset value.
- *3: When a video signal is input, this option is available.
- *4: When “Picture Mode” is set to the item other than “Presentation,” this option is available.
- *5: When a B & W signal is input, this option is not available.
- *6: When an analog TV signal is input, this option may not available, depending on the color system.
- *7: When a progressive signal is input, this option is not available.

The Screen Menu



For adjusting the size, position, and aspect ratio of the projected image for each input signal.

Items	Item descriptions
Aspect ^{*1}	Changes the aspect ratio of the projected image. (page 17).
When the computer signal is input	Normal: Displays the image on the center point of the projected image without changing the resolution of the input signal or enlarging the image. Full1: Displays the image to fit the maximum projected image size without changing the aspect ratio of the input signal. Full2: Displays the image to fit the maximum projected image size.
When the video signal is input	4:3: Displays the image to fit the maximum projected image size with an aspect ratio fixed to 4:3. 16:9: Displays the image to fit the maximum projected image size with an aspect ratio fixed to 16:9. Zoom: Display the center point of the projected image to zoom.
Adjust Signal	Adjusts the image of signal. Use this item if the edge of the image is cut and reception is bad.
APA ^{*2 *3}	Automatically adjusts the projected image to an optimum quality when you press the ENTER key.
Phase ^{*2}	Adjusts the dot phase of the display pixel and the input signal. Set to the value where looks clearest.
Pitch ^{*2}	The higher the setting, the wider the horizontal image elements (pitch). The lower the setting, the narrower the horizontal image elements (pitch).
Shift ^{*4}	H: The higher the setting, the farther right the image is projected on the screen. The lower the setting, the image farther left. V: The higher the setting, the farther up the image is projected on the screen. The lower the setting, the image farther down.

Notes

- *1: • Note that if the projector is used for profit or for public viewing, modifying the original picture by switching to the aspect mode may constitute an infringement of the rights of authors or producers, which are legally protected.
 - Depending on the input signal, setting items for aspect ratio or some other setting items cannot be set in some cases, or changing the aspect ratio setting may have no effect.
 - A part of the image may be displayed in black, depending on the setting item.
- *2: Available when a computer signal is input from the RGB input connector (INPUT A/INPUT B (INPUT B is available only for VPL-EX120/EX145/EX175)).
- *3: If the projected image includes large amount of black portion around it, the APA function will not work properly and a part of the image may not be displayed on the screen and also optimum image cannot be obtained, depending on the type of input signal. In this case, adjust the "Phase," "Pitch," and "Shift" items manually.
- *4: Available when a computer signal is input from the RGB input connector (INPUT A/INPUT B (INPUT B is available only for VPL-EX120/EX145/EX175)) or a video signal is input from the YPbPr input connector (INPUT A).

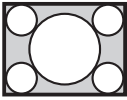
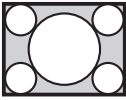
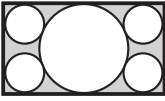
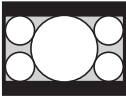
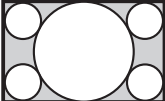
Aspect

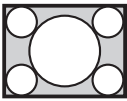
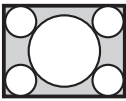
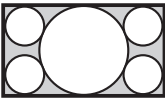
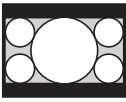
	Input signal	Recommended setting value and projected image
Computer signal	(4:3) 	(Full1) ^{*1} 
	(16:9) 	(Full1) ^{*1 *2} 
	(16:10) 	(Full1) ^{*1 *2} 
Video signal	(4:3) 	(4:3) ^{*3} 
	(16:9) 	(16:9) ^{*4} 

*1: If you select “Normal,” the image is projected in the same resolution as the input signal without changing the aspect ratio of the original image.



*2: If you select “Full2,” the image is projected to fit the projected image size, regardless of the aspect ratio of the image.



*3: Depending on the input signal, the projected image may be projected as illustrated below. In this a case, select “16:9.”

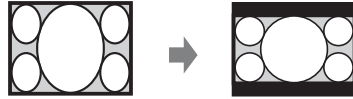

*4: Depending on the input signal, the image may be projected as illustrated below. In this a case, select “Zoom.”



The Function Menu

The Function menu is used for setting various functions of the projector.









Items	Item descriptions
Volume	The higher the setting, the higher an audio volume and the lower the setting, the lower the audio volume. The audio output level will work simultaneously.
Speaker	On/Off: When set to “On,” the sound will be output from the speaker. Set “Off” to mute the sound.
Smart APA	On/Off: When set to “On,” executes APA automatically when a signal is input.*1
CC Display	CC1/CC2/CC3/CC4/Text1/Text2/Text3/Text4: Select the closed caption service (Captions or Text). Off: Closed caption does not appear.
Lamp Mode	High/Standard/Low: When set to “High,” the image becomes brighter, and power consumption becomes higher.
Lamp Timer Reset	When replacing the lamp, resets the lamp timer (page 30).
Background	Black/Blue: Selects the background color of the projected image when no signal is input.
Start Up Image	On/Off: When set to “On,” the Start Up Image is displayed on the screen upon startup of the projector.

Note

*1: Executes APA when a computer signal is input via the RGB input connector (INPUT A/INPUT B (INPUT B is available only for VPL-EX120/EX145/EX175)).

The Operation Menu

The Operation Menu is used for setting for the operations by using the menu or the Remote Commander.

Items	Item descriptions
Language	Selects the language used in the menu and on-screen displays.
Status	On: All on-screen statuses are enabled. Off: Turn off the on-screen displays except for the menus, message when turning off the power, and warning messages.
Security Lock ^{*1}	On/Off: This function enables restriction of the projector to authorized users by password. The setting procedures for security locking are as follows: <ol style="list-style-type: none">1 Select “On” and press ENTER to display the setting menu.2 Input the password with the MENU, , , , , and ENTER keys. (The default password setting is “ENTER, ENTER, ENTER, ENTER.”)3 Input a new password with the MENU, , , , , and ENTER keys.4 Enter the password again to confirm. Enter the password when you turn on the projector after disconnecting and reconnecting the AC power cord. When it is set to “Off,” you can cancel the security lock. You are required to input the password again. If you fail to enter the correct password after three consecutive times, the projector cannot be used. In this case, press the I/⏻ key to go Standby mode then turn on the power again.
Panel Key Lock	On/Off: When set to “On,” locks all the control panel keys of the projector. However, you can operate the following when set to “On”: <ul style="list-style-type: none">• Press and hold the I/⏻ key for approximately 10 seconds during Standby mode. → The projector turns on.• Press and hold the MENU key for approximately 10 seconds during power on. → “Panel Key Lock” is set to “Off” and enables operation of all keys on the projector.

Note

*1: You will not be able to use the projector if you forget your password. If you call qualified Sony personnel because you have forgotten the password, you will be asked to verify the projector’s serial number and your identity. (This process may differ in other countries/regions.) Once your identity has been confirmed, we will provide you with the password.

The Connection/Power Menu

The Connection/Power menu is used for setting for the connections and power.

Items	Item descriptions
Network Setting ^{*3}	
IP Address Setup	Auto (DHCP): The IP address is assigned automatically from the DHCP server such as a router. Manual: To specify the IP Address manually.
IP Address/ Subnet Mask/ Default Gateway/Primary DNS/Secondary DNS	When “Manual” is selected for “IP Address Setup,” select the item with the ◀ or ▶ key and input the value with ▲ or ▼ key. When all items are entered, select “Apply” then press the ENTER key. The entered settings will be registered.
Input-A Signal Sel.	Auto/Computer/Video GBR/Component: When set to “Auto,” selects the type of video signal input automatically when “Input-A” is selected with the INPUT key. ^{*1}
Color System	Auto/NTSC3.58/PAL/SECAM/NTSC4.43/PAL-M/PAL-N: When set to “Auto,” selects the color system automatically when “S Video” or “Video” is selected with the INPUT key. ^{*1}
Standby Mode ^{*2}	Standard/Low: When set to “Low,” lowers power consumption in Standby mode.
Power Saving Mode	Lamp Cutoff: The lamp turns off automatically and power consumption is reduced if no signal is input for 10 minutes. The lamp lights again when a signal is input or any key is pressed. In Lamp Cutoff, the ON/STANDBY indicator lights in orange (page 26). Standby: The power will be turned off automatically and the projector goes to Standby mode if no signal is input for 10 minutes. Off: The Power Saving Mode is canceled.
Direct Power On	On/Off: When set to “On,” you can turn the power on without going to Standby mode when the AC power cord is connected to a wall outlet. Regardless of the Direct Power On setting, you can disconnect the AC power cord to turn off the power without going to the Standby mode.

Notes

- *1: The image may not be adjusted properly depending on the type of input signal. In such a case, adjust it manually to suit to the connected equipment.
- *2: When “Standby Mode” is set to “Low,” the network and network control function cannot be operated while the projector is in standby mode.
- *3: VPL-EX145/EX175 only.

The Installation Menu

The Installation menu is used for installing the projector.

Items	Item descriptions
Image Flip	HV/H/V/Off: Flips the projected image horizontally and/or vertically according to the installation method.
Installation Attitude	Right Side Up/Upside Down: Change the cooling setting to suit to the installation attitude. Continuing to use the wrong setting may affect component reliability.
High Altitude Mode ^{*2}	On/Off: Set to “On” when using the projector at an altitude of 1,500 m or higher. Continuing to use the wrong setting may affect component reliability.
V Keystone ^{*1}	Auto: Set keystone adjustment automatically. When the projector is installed on an uneven surface, the feature may not work properly. In this case, select “Manual” to set keystone adjustment manually. Manual: The higher the setting, narrower the top of the projected image. The lower the setting, narrower the bottom of the projected image.

Notes

- *1: Since the Keystone adjustment is an electronic correction, the image may be deteriorated.
- *2: When “High Altitude Mode” is set to “On,” the speed of the fan increases, and the fan noise becomes slightly louder.



i The Information Menu

The Information menu enables you to confirm various information on the projector, such as the total usage hours of a lamp.

Items	Item descriptions
Model Name	Displays the model name.
Serial No.	Displays the serial number.
fH / fV (horizontal frequency/vertical frequency)*1	Displays the horizontal frequency/vertical frequency of the current input signal.
Signal type	Displays the type of the current input signal.
Lamp Timer	Indicates the total usage time of a lamp.

Note

*1: These items may not be displayed depending on the input signal.

Using Network Features (VPL-EX145/EX175 only)

Connection to the network allows you to operate the following features:

- Checking the current status of the projector via a Web browser.
- Remotely controlling the projector via a Web browser.
- Receiving the e-mail report for the projector.
- Making the network settings for the projector.
- Supports network monitoring, control protocol (Advertisement, PJ Talk, PJ Link, SNMP, AMX DDDP [Dynamic Device Discovery Protocol]).

Notes

- The menu displays used for the explanation below may be different depending on the model you are using.
- Supported Web browsers are Internet Explorer 6/7/8.
- The menu displays only English.
- If the browser of your computer is set to [Use a proxy server] when you have access to the projector from your computer, click the check mark to set accessing without using a proxy server.

Displaying the Control Window of the Projector with a Web Browser

1 Connect the LAN cable.

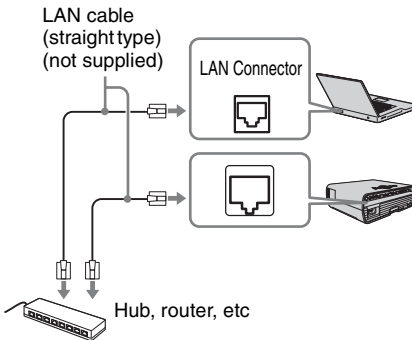

2 Set the network settings for the projector using “Network Setting” on the Connection/Power menu (page 20).

3 Start a web browser on the computer, enter the following in the address field, then press the Enter key on your computer.
`http://xxx.xxx.xxx.xxx`

(xxx.xxx.xxx.xxx: IP address for the projector)
You can confirm the IP address of the projector under “Network Setting” on the Connection/Power menu.

The following window appears in the Web browser:

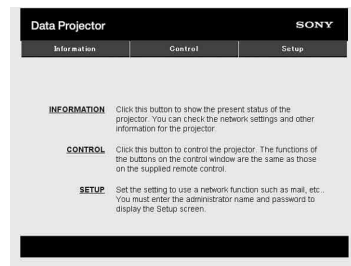

Once you make the network settings, you can open the Control window only by performing step **3** of this procedure.

How to operate the Control window

Switching the page

Click one of the Page Switching buttons to display the desired setting page.



Page Switching buttons

Setting the access limitation

You can limit a user for accessing any particular page.

Administrator: Allowed access to all pages

User: Allowed access to all pages except the Setup page

Set under [Password] of the Setup page. When you access the Setup page for the first time, enter “root” for user name and enter nothing for password. The name of the administrator is preset to “root.”

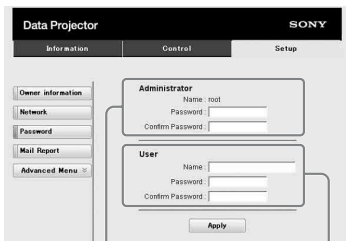

Entry area for [Administrator]

Entry area for [User]

When you change the password, input a new password after deleting the password (*****) that was set.

Note

If you forget your password, consult with qualified Sony personnel.

Confirming the Information regarding the Projector

You can confirm the current settings for the projector on the Information page.



Information area

Operating the Projector from a Computer

You can control the projector from the computer on the Control page.

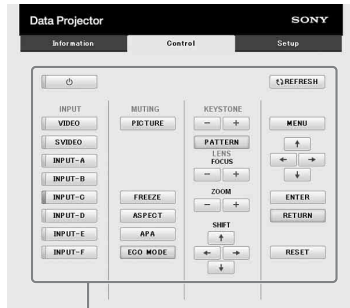

Operation area

The functions of the keys shown in the operation area are the same as those of the keys on the supplied Remote Commander.

Using the e-mail report Function

Set the e-mail report function on the Setup page.

Entered values will not be applied unless you click on [Apply].

- 1 Click on [Owner information] to enter the owner information recorded in the e-mail report.

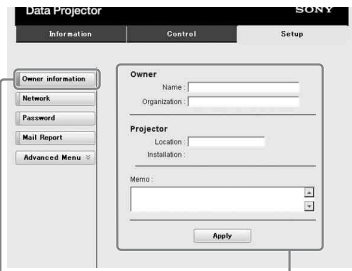

Owner information button 1

- 2 Set the timing of the e-mail report. Click on [Mail Report] to open the Mail Report page.

Lamp Reminder (Lamp1): Set the timing for lamp replacement. To reset Lamp Reminder, execute “Lamp Timer Reset” on the projector (page 18).

Maintenance Reminder: Set the timing for maintenance. To reset Maintenance Reminder, check the RESET check box and then click on [Apply].

Mail Report button

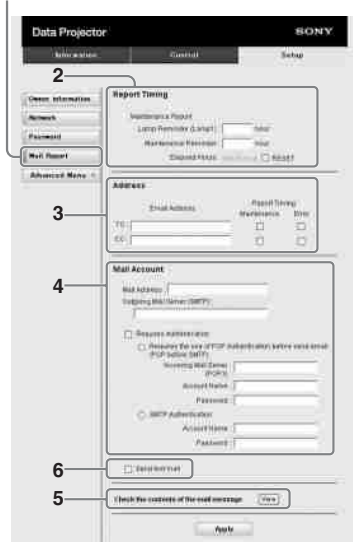

- 3 Enter the outgoing e-mail address in the Email Address box then check the Report Timing check box of the e-mail report to be sent.

- 4 Set the mail account for sending e-mail reports.

Mail Address: Enter the e-mail address.
Outgoing Mail Server (SMTP): Enter the address of outgoing mail server (SMTP).

Required Authentication: Check this check box if authentication is required for sending e-mail.

Requires the use of POP

Authentication before send email

(POP before SMTP): Check this check box to arrange for POP authentication to be performed before sending e-mail.

Incoming Mail Server (POP3): Enter the address of the incoming-mail server (POP3) to be used for POP authentication.

Account Name: Enter the mail account.

Password: Enter the password.

SMTP Authentication: Check this check box to arrange for SMTP authentication to be performed before sending e-mail.

Account Name: Enter the mail account.

Password: Enter the password.

- 5 Confirm the contents of the e-mail report.

When you click on [View] is pressed, the contents of the e-mail report are displayed.

- 6 Send the test mail.

Check on the Send test mail check box then click on [Apply] to send your test mail to the e-mail address you set.

Notes

- The e-mail report function is not available because the network which Outbound Port25 Blocking is used cannot be connected to the SMTP server.
- You cannot use the following characters to enter the characters in the text box: ‘ ’, “ ”, “ \ ”, “ & ”, “ < ”, “ > ”

Indicators

The indicators allow checking the status and notify you of abnormal operation of the projector. If the projector exhibits abnormal status, address the problem in accordance with the table below.

ON/STANDBY indicator

Status	Meaning/Remedies
Lights in red	The projector is in Standby mode.
Flashes in green	<ul style="list-style-type: none"> • The projector is ready to operate after having been turned on. • The lamp cools after the projector is turned off.
Lights in green	The projector's power is on.
Lights in orange	The projector is in Power Saving Mode (lamp cut off). (page 20)
Flashes in red	The projector is in abnormal status. Symptoms are indicated by number of flashes. Address the problem in accordance with the following. If the symptom is shown again, consult with qualified Sony personnel.
Flashes twice	<p>The internal temperature is unusually high. Check the items below.</p> <ul style="list-style-type: none"> • Check to see if nothing is blocking the ventilation holes. • Check to see if the air filter is not clogged. • Check if "Installation Attitude" on the Installation menu is correctly selected. (page 3, page 32, page 21)
Flashes six times	Unplug the AC power cord from a wall outlet. After checking that the ON/STANDBY indicator goes out, plug the power cord to a wall outlet again then turn on the projector.
Other number of flashes	Consult with qualified Sony personnel.

LAMP/COVER indicator

Status	Meaning/Remedies
Flashes in red	Symptoms are indicated by number of flashes. Address the problem in accordance with the following.
Flashes twice	The lamp cover is not attached securely. (page 32)
Flashes three times	The temperature of lamp is unusually high. Turn off the power and wait for lamp to cool then turn on the power again. If the symptom is shown again, the lamp may be burnt out. In such a case, replace the lamp with a new one (page 30).

Messages List

When any of the messages listed below appears on the projected image, address the problem in accordance with the table below.

Message	Meaning/Remedy	Page
High temp.! Lamp off in 1 min.	Check the items below. <ul style="list-style-type: none"> • Check to see if nothing is blocking the ventilation holes. • Check to see if the air filter is not clogged. • Check if “Installation Attitude” on the Installation menu is correctly selected. 	3, 21, 32
Frequency is out of range!	Change the output setting of the connected equipment to one for signals supported by the projector.	37
Please check Input-A Signal Sel.	Set “Input-A Signal Sel.” to “Auto” or select the input signal type to suit to the input signal.	20
Please replace the Lamp and clean the Filter.	Replace the lamp with a new one and clean the air filter. To cancel the message, press any key on the Remote Commander or the control panel of the projector. The message appears whenever you turn on the power until you replace the lamp and reset the lamp timer.	30, 32
Projector temperature is high. High Altitude Mode should be “On” if the projector is being used at high altitude.	At an altitude of 1,500 m or higher, if you are not using the projector, check the items below. <ul style="list-style-type: none"> • Check that nothing is blocking the ventilation holes. • Check that the air filter is not clogged. • Check if “Installation Attitude” on the Installation menu is correctly selected. 	3, 21, 32
Not applicable!	Invalid key pressed.	–
The panel keys are locked!	“Panel Key Lock” is set to “On.”	19

Troubleshooting

Before asking to have the projector repaired, try to diagnose the problem, following the instructions below.

Symptom	Remedy	Page
The power is not turned on.	Check if the AC power cord is firmly connected.	–
	When the “Panel Key Lock” is set to “On,” you cannot turn on the projector using the I/⏻ key on the projector.	19
	If the lamp and lamp cover is not attached securely, the projector cannot be turned on.	30
No image.	Check if the connecting cable is connected to external equipment firmly.	–
	Check if the computer signal is set for output to an external monitor. If you set your computer, such as a notebook computer, to output the signal to both your computer’s display and an external monitor, the picture of the external monitor may not appear properly. Set your computer to output the signal to only an external monitor.	10
	Check if the input source is correctly selected.	10
	Check if the picture is muted.	6
On-screen display does not appear.	The on-screen display does not appear when “Status” in the Operation menu is set to “Off.”	19
The aspect ratio of the display is not right/the image is displayed smaller /a portion of image does not appear.	Set “Aspect” manually.	5, 16, 17
The image is a trapezoid.	The images become trapezoidal because of the projection angle. In such a case, you can correct the trapezoidal distortion, using a Keystone feature.	5, 12, 21
	When the “V Keystone” is set to “Manual,” the keystone feature does not work automatically. Set “V Keystone” to “Auto” or “Manual” to set manually.	5, 12, 21
	When the projector is installed on an uneven surface, the feature may not work properly. In this case, select “Manual” to set “V Keystone” manually.	5, 12, 21
The image is dark/too bright.	The settings for “Brightness,” “Contrast,” and “Lamp Mode” affect brightness of the image. Check if the value is appropriate.	15, 18
	The image will be dark when the lamp is burnt out. Check “Lamp Timer,” and replace the lamp with a new one if necessary.	22
The image is not clear.	Check if the projector is in focus.	11
	The picture will not be clear if condensation has accumulated on the lens. In such a case, let the projector sit for about two hours with the power on.	–

Symptom	Remedy	Page
The image is noisy.	Check if the connecting cable is connected to external equipment properly.	7
No sound.	Check that the connecting cables between the projector and external video or audio equipment are securely connected.	7
	Check if the connecting cable is connected to external equipment firmly.	–
	Audio is not output if audio muting is activated.	6
	Audio is not output if “Speaker” is set to “Off.”	18
	Check if “Volume” is not set to minimum.	6, 18
The Remote Commander does not work.	Check that the batteries are installed correctly.	–
	Check that the batteries are not exhausted.	–
The fan is noisy.	The sound from the fan is often greater than normal to cool the lamp, etc. in the following cases. <ul style="list-style-type: none"> • “Lamp Mode” is set to “High.” • “High Altitude Mode” is set to “On.” • The unit is used in the location where the temperature is high. 	18, 21
	If the ventilation holes are blocked, the internal temperature of the projector rises and the fan noise becomes larger.	3

Replacing the Lamp

Replace the lamp with a new one if a message displayed on the projected image or the LAMP/COVER indicator notifies you to replace the lamp (pages 26, 27).
Use an LMP-E211 projector lamp (not supplied) for replacement.

Caution

- The lamp remains hot after the projector is turned off. **If you touch the lamp, you may burn your finger. When you replace the lamp, wait for at least an hour after turning off the projector for the lamp to cool sufficiently.**
- Do not allow any metallic or inflammable objects into the lamp replacement slot after removing the lamp, otherwise it may cause electrical shock or fire. Do not put your hands into the slot.
- **If the lamp breaks, contact qualified Sony personnel. Do not replace the lamp yourself.**
- When removing the lamp, be sure to pull it out straight, by holding the designated location. If you touch a part of the lamp other than the designated location, you may be burned or injured. If you pull out the lamp while the projector is tilted, the pieces may scatter if the lamp breaks any may cause injury.

- 1** Turn off the projector, and disconnect the AC power cord from a wall outlet.
- 2** When the lamp has cooled sufficiently, open the lamp cover by loosening 1 screw.

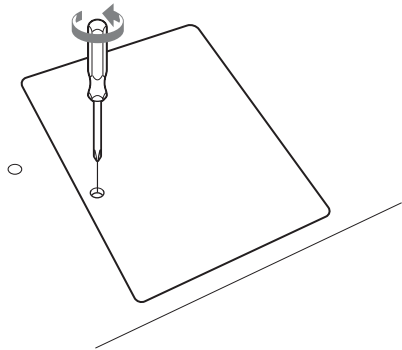

- 3** Loosen the 2 screws on the lamp then pull out the lamp by its grab.

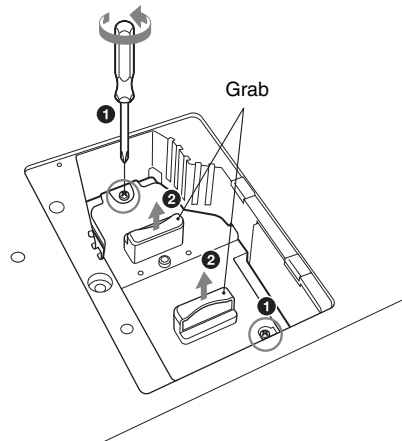

- 4 Insert the new lamp all the way in until it is securely in place. Tighten the 2 screws.

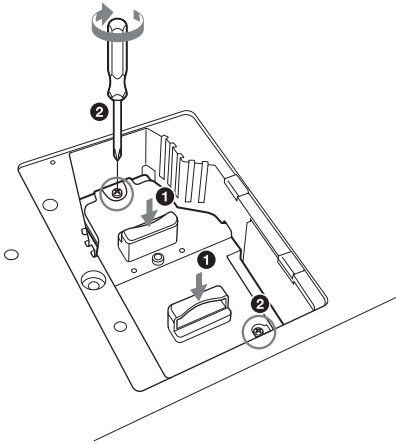

- 5 Close the lamp cover and tighten the 1 screw.

Note

Be sure to install the lamp and Lamp cover securely as it was. If not, the projector cannot be turned on.

- 6 Connect the AC power cord to a wall outlet and turn on the projector.
- 7 Reset the lamp timer for notification of the next replacement time.
Select “Lamp Timer Reset” on the Function menu then press the ENTER key. When a message appears, select “Yes” to reset the lamp timer (page 18).

Caution

**Disposal of the used lamp
For the customers in the USA**

Lamp in this product contains mercury. Disposal of these materials may be regulated due to environmental considerations. For disposal or recycling information, please contact your local authorities or the Telecommunications Industry Association (www.eiae.org).

Cleaning the Air Filter

When a message appears on the projected image, clean the air filter (page 27).

If the dust cannot be removed from the air filter even after cleaning, replace the air filter with a new one.

For details on a new air filter, consult with qualified Sony personnel.

Caution

If you neglect to clean the air filter, dust may accumulate, clogging it. As a result, the temperature may rise inside the unit, leading to a possible malfunction or fire.

1 Turn off the projector, and disconnect the AC power cord from the AC outlet.

2 Draw out the air filter cover.

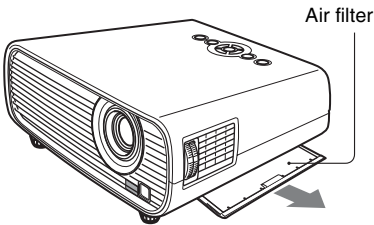

4 Attach the air filter cover to the unit.

Note

Be sure to attach the air filter cover firmly. Incorrect attachment of the cover may cause a malfunction.

3 Clean the air filter with a vacuum cleaner.

Remove the air filter as illustrated below then clean with the vacuum cleaner.

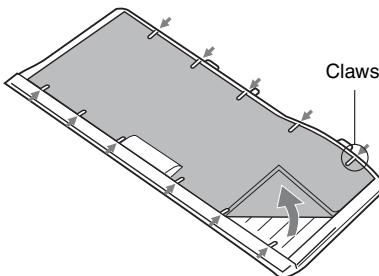

Specifications

Item	Description	
Model	VPL-EX100/EX120/EX145/EX175	
Projection system	3 LCD system	
Display device	Effective display size	0.63-inch (16.0 mm), 3 plate, Aspect ratio 4:3
	Effective picture elements	2,359,296 pixels (1024 × 768 pixels, 3 plate panels)
Projection lens	Zoom	Manual zoom (approx.1.3 times)
	Focus	Manual
Light source	High-pressure mercury lamp, 210 W type	
Projected image size	30 inches to 300 inches (0.762 m to 7.62m)	
Luminous flux (Brightness)	VPL-EX100: 2300 lm (when “Lamp Mode” is set to “High”) VPL-EX120: 2600 lm (when “Lamp Mode” is set to “High”) VPL-EX145: 3100 lm (when “Lamp Mode” is set to “High”) VPL-EX175: 3600 lm (when “Lamp Mode” is set to “High”)	
Speaker	VPL-EX100/EX120: 1W × 1 (monaural) VPL-EX145/EX175: 10W × 1 (monaural)	
Applicable scanning frequency *1	Horizontal: 14 kHz to 93 kHz, Vertical: 47 Hz to 93 Hz	
Resolution	When a computer signal is input	Maximum display resolution: 1600 × 1200 pixels (resize) Panel display resolution: 1024 × 768 pixels
	When a video signal is input	NTSC, PAL, SECAM, 480/60i, 576/50i, 480/60p, 576/50p, 720/60p, 720/50p, 1080/60i, 1080/50i
Color system	NTSC ^{3.58} , PAL, SECAM, NTSC ^{4.43} , PAL-M, PAL-N, PAL60	
INPUT OUTPUT (Computer/video)	INPUT A	RGB/YPbPr input connector: Mini D-sub 15 pin female, G with sync/Y: 1 Vp-p ± 2 dB, sync negative, 75 ohms terminated, RGB/PbPr: 0.7 Vp-p ± 2 dB, 75 ohms terminated, Sync signal: TTL level high impedance, positive/negative Audio input connector: Stereo mini jack, rated input 500 mVrms, input impedance more than 47 kohms
	INPUT B (VPL-EX120/EX145/EX175 only)	RGB input connector: Mini D-sub 15-pin female, RGB: 0.7 Vp-p ± 2 dB, 75 ohms terminated, Sync signal: TTL level high impedance, positive/negative Audio input connector: Stereo mini jack, rated input 500 mVrms, input impedance more than 47 kohms

Item	Description
Model	VPL-EX100/EX120/EX145/EX175
INPUT OUTPUT (Computer/video)	<p>S VIDEO (S VIDEO IN) S video input connector: Mini DIN 4-pin, Y: 1 V_{p-p} ± 2 dB, sync negative, 75 ohms terminated, C: (burst signal) 0.286 (NTSC)/0.3 (PAL/SECAM) V_{p-p} ± 2 dB, 75 ohms terminated</p> <p>Audio input connector: Phono jack × 2, rated input 500 mVrms, Input impedance more than 47 kohms</p>
VIDEO (VIDEO IN)	<p>Video input connector: Phono jack, 1 V_{p-p} ± 2 dB, sync negative, 75 ohms terminated</p> <p>Audio input connector: Shared with S VIDEO IN</p>
OUTPUT	<p>MONITOR output connector: Mini D-sub 15-pin female, G with sync/Y: 1 V_{p-p} ± 2 dB, sync negative, 75 ohms terminated, RGB/PbPr: 0.7 V_{p-p} ± 2 dB, 75 ohms terminated, Sync signal: HD, VD 4 V (open), 1 V_{p-p} (75 ohms), positive/negative</p> <p>Audio output connector: Stereo mini jack, stereo, 1 Vrms (maximum volume, when inputting 500 mVrms), output impedance 5 kohms</p>
Others connector	<p>RS-232C connector: D-Sub 9 pin female</p> <p>LAN connector (VPL-EX145/EX175 only): RJ45, 10BASE-T/100BASE-TX</p>
Operating temperature/ Operating humidity	0 °C to 40 °C (32 °F to 104 °F)/35% to 85% (no condensation)
Storage temperature/ Storage humidity	-20 °C to +60 °C (-4 °F to +140 °F)/ 10% to 90%
Power requirements	<p>VPL-EX100/EX120: 100 V to 240 V AC, 3.0 A-1.5 A, 50/60 Hz</p> <p>VPL-EX145/EX175: 100 V to 240 V AC, 3.2 A-1.6 A, 50/60 Hz</p>
Power consumption	<p>VPL-EX100/EX120: 100 V AC: 300 W 240 V AC: 290 W</p> <p>VPL-EX145/EX175: 100 V AC: 320 W 240 V AC: 310 W</p>
Standby power	<p>VPL-EX100/EX120: 100 V AC: 8 W (when “Standby Mode” is set to “Standard”)/1 W (when “Standby Mode” is set to “Low”) 240 V AC: 10 W (when “Standby Mode” is set to “Standard”)/1 W (when “Standby Mode” is set to “Low”)</p> <p>VPL-EX145/EX175: 100 V AC: 9 W (when “Standby Mode” is set to “Standard”)/1 W (when “Standby Mode” is set to “Low”) 240 V AC: 11 W (when “Standby Mode” is set to “Standard”)/1 W (when “Standby Mode” is set to “Low”)</p>

Item	Description
Model	VPL-EX100/EX120/EX145/EX175
Heat dissipation	VPL-EX100/EX120: 100 V AC: 1023BTU 240 V AC: 989BTU VPL-EX145/EX175: 100 V AC: 1091BTU 240 V AC: 1057BTU
Standard dimensions (W/H/D)	Approx. 313.4 × 129.6 × 278.3 mm (12 ¹¹ / ₃₂ × 5 ³ / ₃₂ × 10 ³¹ / ₃₂) Approx. 313.4 × 114.1 × 269 mm (12 ¹¹ / ₃₂ × 4 ¹ / ₂ × 10 ¹⁹ / ₃₂ inches) (without projecting parts)
Mass	VPL-EX100/EX120: Approx. 3.2 kg (7lb 0.88 oz) VPL-EX145/EX175: Approx. 3.3 kg (7lb 4.4 oz)
Supplied accessories	See “Checking the Supplied Accessories” in the supplied Quick Reference Manual.
Optional accessories *2 *3	Projector Lamp LMP-E211 (for replacement)

Notes

- *1: For details, refer to “Acceptable Input Signals” on page 37.
- *2: Information on accessories in this manual is current as of August 2010.
- *3: Not all optional accessories are available in all countries and area. Please check with your local Sony Authorized Dealer.

Design and specifications of the unit, including the optional accessories, are subject to change without notice.

Always verify that the unit is operating properly before use. SONY WILL NOT BE LIABLE FOR DAMAGES OF ANY KIND INCLUDING, BUT NOT LIMITED TO, COMPENSATION OR REIMBURSEMENT ON ACCOUNT OF THE LOSS OF PRESENT OR PROSPECTIVE PROFITS DUE TO FAILURE OF THIS UNIT, EITHER DURING THE WARRANTY PERIOD OR AFTER EXPIRATION OF THE WARRANTY, OR FOR ANY OTHER REASON WHATSOEVER.

Others

Pin assignment

RGB input connector (Mini D-sub 15-pin, female)

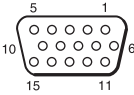

1	Video input (red) R	9	Power supply input for DDC
2	Video input (green) G	10	GND
3	Video input (blue) B	11	GND
4	GND	12	DDC/SDA
5	RESERVE	13	Horizontal sync signal
6	GND (R)	14	Vertical sync signal
7	GND (G)	15	DDC/SCL
8	GND (B)		

RS-232C connector (D-Sub 9-pin, female)

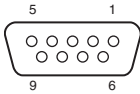

1	NC	6	NC
2	RXDA	7	RTS
3	TXDA	8	CTS
4	DTR	9	NC
5	GND		

Acceptable Input Signals

Computer signal

Resolution	fH [kHz]/ fV [Hz]	Input connector
		RGB
640 × 350	31.5/70	●
	37.9/85	●
640 × 400	31.5/70	●
	37.9/85	●
640 × 480	31.5/60	●
	35.0/67	●
	37.9/73	●
	37.5/75	●
	43.3/85	●
800 × 600	35.2/56	●
	37.9/60	●
	48.1/72	●
	46.9/75	●
	53.7/85	●
832 × 624	49.7/75	●
1024 × 768	48.4/60	●
	56.5/70	●
	60.0/75	●
	68.7/85	●
1152 × 864	64.0/70	●
	67.5/75	●
	77.5/85	●
1152 × 900	61.8/66	●
1280 × 960	60.0/60	●
	75.0/75	●
1280 × 1024	64.0/60	●
	80.0/75	●
	91.1/85	●
1400 × 1050	65.3/60	●
1600 × 1200	75.0/60	●
1280 × 768	47.8/60	●
1280 × 720	45.0/60	●
1360 × 768	47.7/60	●

Resolution	fH [kHz]/ fV [Hz]	Input connector
		RGB
1440 × 900	55.9/60	●
1280 × 800	49.7/60	●

Digital TV signal

Signal	fV [Hz]	Input connector
		RGB ^{*1} / YPbPr
480i	60	●
576i	50	●
480p	60	●
576p	50	●
1080i	60	●
1080i	50	●
720p	60	●
720p	50	●

Analog TV signal

Signal	fV [Hz]	Input connector
		VIDEO/ S VIDEO
NTSC	60	●
PAL/SECAM	50	●

Notes

*1: With INPUT A only

- When a signal other than the signals listed in table is input, the picture may not be displayed properly.
- An input signal meant for screen resolution different from that of the panel will not be displayed in its original resolution. Text and lines may be uneven.

Others

Projection Distance

The following describes the projection distance and height from lens center to bottom of screen by each projected screen size.

The projection distance is the distance between the front of the lens and the surface of the projected image.

Height H is the height from the bottom of the projected image (top for ceiling mount) to A (determined by drawing a perpendicular line from lens center to projected image surface).

Floor Installation (Adjuster not stretched, and the V Keystone function has been done.)

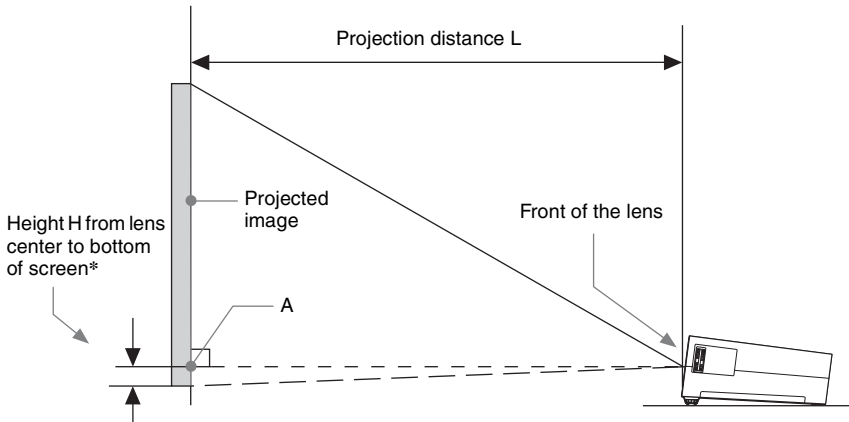

* The number will be minus when the bottom of the projected image is lower than A.

Projection distance

Unit: m (inches)

Projected image size		Projection Distance L	Height H from lens center to bottom of screen	
Diagonal D	Width × Height		Minimum Projection Distance L	Maximum Projection Distance L
80 inch (2.03 m)	1.63 × 1.22 (64 × 48)	2.28–2.94 (90–115)	–0.11 (–0.04)	–0.02 (–0.01)
100 inch (2.54 m)	2.03 × 1.52 (80 × 60)	2.85–3.68 (113–145)	–0.13 (–0.05)	–0.02 (–0.01)
120 inch (3.05 m)	2.44 × 1.83 (96 × 72)	3.43–4.42 (135–174)	–0.16 (–0.06)	–0.03 (–0.01)
150 inch (3.81 m)	3.05 × 2.29 (120 × 90)	4.29–5.54 (169–218)	–0.20 (–0.08)	–0.03 (–0.01)
200 inch (5.08 m)	4.06 × 3.05 (160 × 120)	5.73–7.40 (226–291)	–0.27 (–0.10)	–0.04 (–0.02)

Projection distance formula

D: Projected image size (Diagonal)

H: Distance between the bottom edge of the image and the center of the lens

Expression#1 (Projection Distance L)

Unit: m (inches)

Minimum Projection Distance L	Maximum Projection Distance L
$L=0.0288 \times D - 0.0296$ (L=1.1337 × D – 1.1659)	$L=0.0371 \times D - 0.0290$ (L=1.4625 × D – 1.1420)

Expression#2 (Height H from lens center to bottom of screen)

Minimum Projection Distance L	Maximum Projection Distance L
H= – 0.00134 × D + 0.00090 (H= – 0.00053 × D + 0.00035)	H= – 0.00021 × D – 0.00048 (H= – 0.00008 × D – 0.00019)

Ceiling Installation (The unit is set so that the bottom is parallel to the ceiling. The V Keystone function has been done.)

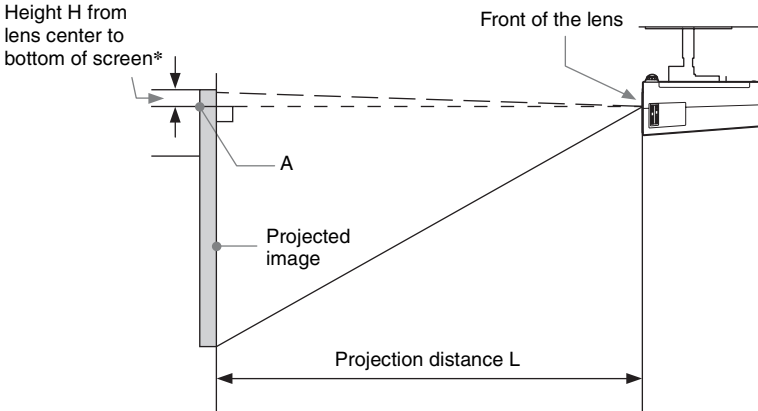

* The number will be minus when the top of the projected image is higher than A.

Projection distance

Unit: m (inches)

Projected image size		Projection Distance L	Height H from lens center to bottom of screen	
Diagonal D	Width × Height		Minimum Projection Distance L	Maximum Projection Distance L
80 inch (2.03 m)	1.63 × 1.22 (64 × 48)	2.27–2.93 (90–115)	– 0.23 (– 0.09)	– 0.18 (– 0.07)
100 inch (2.54 m)	2.03 × 1.52 (80 × 60)	2.84–3.67 (112–144)	– 0.29 (– 0.12)	– 0.23 (– 0.09)
120 inch (3.05 m)	2.44 × 1.83 (96 × 72)	3.42–4.42 (135–174)	– 0.35 (– 0.14)	– 0.28 (– 0.11)
150 inch (3.81 m)	3.05 × 2.29 (120 × 90)	4.28–5.53 (169–217)	– 0.44 (– 0.17)	– 0.34 (– 0.14)
200 inch (5.08 m)	4.06 × 3.05 (160 × 120)	5.71–7.38 (225–290)	– 0.59 (– 0.23)	– 0.46 (– 0.18)

Projection distance formula

D: Projected image size (Diagonal)

H: Distance between the top edge of the image and the center of the lens

Expression#1 (Projection Distance L)

Unit: m (inches)

Minimum Projection Distance L	Maximum Projection Distance L
$L=0.0287 \times D - 0.0296$ ($L=1.1289 \times D - 1.1665$)	$L=0.0371 \times D - 0.0290$ ($L=1.4597 \times D - 1.1431$)

Expression#2 (Height H from lens center to bottom of screen)

Minimum Projection Distance L	Maximum Projection Distance L
$H= - 0.00296 \times D + 0.00258$ ($H= - 0.00117 \times D + 0.00102$)	$H= - 0.00231 \times D + 0.00116$ ($H= - 0.00091 \times D + 0.00046$)

In the case of ceiling mounting, check with your dealer regarding the use of a mount kit that is warranted for use with this product.

Dimensions

Front

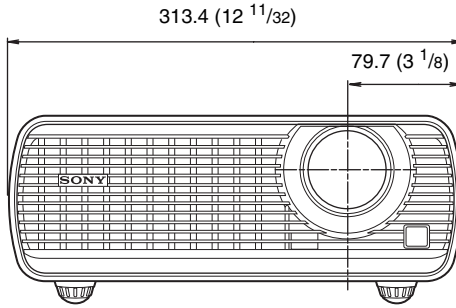

Unit: mm (inches)

Side

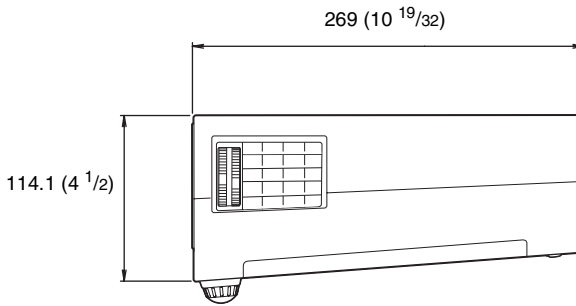

Unit: mm (inches)

Others

Side (The bottom is parallel to the ceiling.)

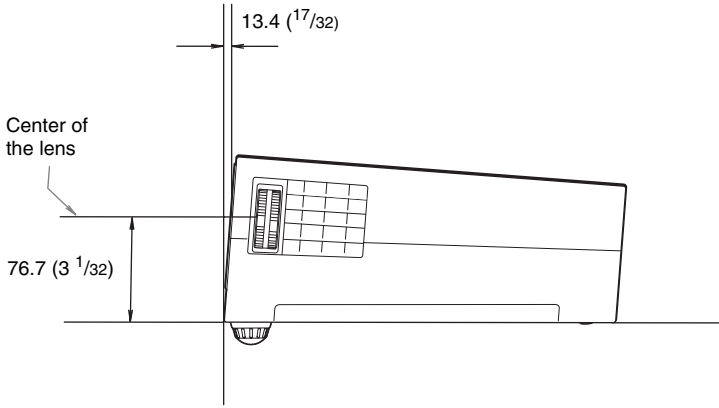

Unit: mm (inches)

Bottom

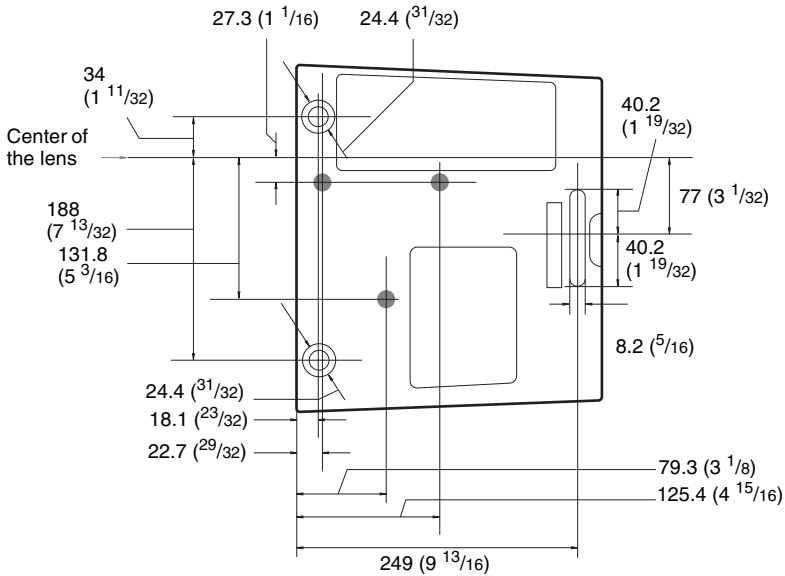

Unit: mm (inches)

Index

A

AC IN	4
Acceptable input signal	37
Adjust Signal	16
Adjuster	3, 11
Air filter	32
Air filter cover/Ventilation holes (intake)	3
APA	5, 16
Aspect	5, 16, 17
Audio muting	6

B

Background	18
Brightness	15

C

CC Display	18
Color	15
Color System	20
Color Temp.	15
Connecting a computer	7
Connecting an external monitor and audio equipment	9
Connecting a Video equipment	8
Connection/Power menu	20
Connector panel	3, 4
Contrast	15
Control panel	5

D

Default Gateway	20
Digital Zoom	5
Direct Power On	20

E

ECO MODE (Energy-saving mode)	6
-------------------------------------	---

F

fH	22
Film Mode	15
Focus	11
Focus ring	3
Freeze	6
Function menu	18
fV	22

G

Gamma Mode	15
------------------	----

H

High Altitude Mode	21
Hue	15

I

Image Flip	21
Information menu	22
Input	4
Input-A Signal Sel.	20
Installation menu	21
IP Address	20
IP Address Setup	20

K

Keystone	5
----------------	---

L

Lamp cover	3
Lamp Mode	18
Lamp Timer	22
Lamp Timer Reset	18
LAMP/COVER indicator	3, 26
LAN	4
Language	19
Location and function of controls	3

M

Main unit	3
Messages list	27
Model Name	22

O

ON/STANDBY indicator	3, 26
Operation menu	19
Output	4

P

Panel Key Lock	19
Pattern	5, 12
Phase	16
Picture menu	15
Picture mode	15
Picture muting	6
Pin assignment	36
Pitch	16
Power Saving Mode	20

Primary DNS	20
Projecting an image	10
Projection distance	38

R

Remote commander	5
Remote control detector	3
Replacing the lamp	30
Reset	15
RS-232C	4

S

Screen menu	16
Secondary DNS	20
Security bar	3
Security Lock	3, 19
Selecting an input signal	5
Serial No.	22
Sharpness	15
Shift	16
Smart APA	18
Specifications	33
Standby Mode	20
Start Up Image	18
Status	19
Subnet Mask	20

T

Troubleshooting	28
Turn off	5, 13
Turn on	5, 10

U

Using a menu	14
--------------------	----

V

V Keystone	5, 12, 21
Ventilation holes	3
Volume	6

Z

Zoom	11
Zoom ring	3

About Trademarks

- Adobe Acrobat is a trademark of Adobe Systems Incorporated.
- Kensington is a registered trademark of Kensington Technology Group.
- Internet Explore is registered trademarks of Microsoft Corporation in the United States and/or other countries.
- PJLink is a registered trademark of Japan Business Machine and Information System Industries Association.
- AMX is a trademark of AMX Corporation.
- All other trademarks and registered trademarks are trademarks or registered trademarks of their respective holders. In this manual, TM and [®] marks are not specified.

