

# *SR Projector*

---

## **Operating Instructions**

Before operating the unit, please read this manual thoroughly and retain it for future reference.

**SRX-R110**  
**SRX-R105**

© 2005 Sony Corporation

## **WARNING**

**To reduce the risk of fire or electric shock, do not expose this apparatus to rain or moisture.**

**To avoid electrical shock, do not open the cabinet. Refer servicing to qualified personnel only.**

## **WARNING**

THIS APPARATUS MUST BE EARTHED.

### **For the customers in the USA**

This equipment has been tested and found to comply with the limits for a Class A digital device, pursuant to Part 15 of the FCC Rules. These limits are designed to provide reasonable protection against harmful interference when the equipment is operated in a commercial environment. This equipment generates, uses, and can radiate radio frequency energy and, if not installed and used in accordance with the instruction manual, may cause harmful interference to radio communications. Operation of this equipment in a residential area is likely to cause harmful interference in which case the user will be required to correct the interference at his own expense.

You are cautioned that any changes or modifications not expressly approved in this manual could void your authority to operate this equipment.

The shielded interface cable recommended in this manual must be used with this equipment in order to comply with the limits for a digital device pursuant to Subpart B of Part 15 of FCC Rules.

### **For the customers in Europe**

## **WARNING**

This is a Class A product. In a domestic environment, this product may cause radio interference in which case the user may be required to take adequate measures.

### **Voor de klanten in Nederland**



Gooi de batterij niet weg maar lever deze in als klein chemisch afval (KCA).

---

# Table of Contents

---

## Chapter 1 Overview

<b>Precautions .....</b>	<b>5</b>
<b>Features .....</b>	<b>6</b>
<b>Location and Function of Controls .....</b>	<b>7</b>
Front/Top .....	7
Left Side/Rear .....	8
Control Function Menu Window .....	8
Remote Commander .....	10

---

## Chapter 2 Preparations

<b>Precautions on Installation .....</b>	<b>12</b>
Unsuitable Installation .....	12
Unsuitable Conditions .....	13
<b>Installation .....</b>	<b>13</b>
Using the Carrying Handles .....	13
Using the Adjusters .....	13
Installing the Projector .....	14
<b>Installing the SRX Controller in a Computer for Controlling the     Projector .....</b>	<b>14</b>
System Requirements .....	14
Installing the SRX Controller .....	14
<b>Connecting a Computer for Controlling the Projector .....</b>	<b>16</b>
Connecting the Computer via the Ethernet .....	16
Connecting the Computer via the RS-232C .....	16
<b>Starting the SRX Controller .....</b>	<b>17</b>
Starting the SRX Controller .....	17
Changing the Connection Mode .....	17
<b>Connecting the Projector .....</b>	<b>18</b>
Connecting with HD-SDI Equipment .....	18
Connecting with Component/Video GBR Equipment .....	18
Connecting with a Computer .....	19

---

## Chapter 3 Projecting

<b>Projecting the Picture .....</b>	<b>20</b>
Using the Remote Commander .....	20
Using the Computer for Controlling the Projector .....	22

---

## Chapter 4 Adjustments and Settings Using the SRX Controller

<b>Displaying the Control Function Menu Window .....</b>	<b>24</b>
<b>PICTURE CONTROL Window .....</b>	<b>25</b>
Input Source .....	25
Signal Info (Information) .....	25
Signal Adjust .....	26
<b>COLOR/FRAME Window .....</b>	<b>26</b>
Color .....	26
Frame Adjust .....	27
<b>INSTALLATION Window .....</b>	<b>27</b>
LENS CONTROL .....	27
PROGRESSIVE DISPLAY MODE .....	27
LAMP POWER .....	27
INSTALLATION .....	28
LAMP SELECT .....	28
TEST PATTERN .....	28
<b>Input Signals And Adjustable/Setting Items .....</b>	<b>29</b>

---

## Chapter 5 Others

<b>Lamp Life .....</b>	<b>30</b>
<b>Troubleshooting .....</b>	<b>31</b>
<b>Error Messages .....</b>	<b>32</b>
<b>Specifications .....</b>	<b>34</b>
<b>Index .....</b>	<b>37</b>

## Precautions

### On safety

- Operate the unit on 200 – 240 V AC, 50/60 Hz (SRX-R110), or 100 – 240 V AC, 50/60 Hz (SRX-R105).
- Should any liquid or solid object fall into the cabinet, unplug the unit and have it checked by qualified Sony personnel before operating it further.
- Unplug the unit from the wall outlet or set the power switch to the lower position if it is not to be used for several days.
- To disconnect the cord, pull it out by the plug. Never pull the cord itself.
- The wall outlet should be near the unit and easily accessible.
- The unit is not disconnected from the AC power source (mains) as long as it is connected to the wall outlet and the power switch is set to the upper position.
- Do not look into the lens while the lamp is on.
- Do not place your hand or objects near the ventilation holes. The air coming out is hot.
- Have at least four people carry and handle the projector, to avoid accidents or injury.
- Avoid using an extension cord with a low voltage limit, as it may cause short-circuiting and physical injury.
- To carry the projector, be sure to use the carrying handles. Do not hold other parts of the projector, especially the lens, nor catch your finger between the handle, floor, and the projector.
- Do not catch your finger between the unit and surface of the floor when moving the projector installed on the floor.
- Be careful not to catch your finger in the cooling fan.

### On installation

- Allow adequate air circulation to prevent internal heat build-up. Do not place the unit on surfaces (rugs, blankets, etc.) or near materials (curtains, draperies) that may block the ventilation holes. Leave space of more than 100 cm (39 <sup>3</sup>/<sub>8</sub> inches) between the wall and the

projector. Be aware that room heat rises to the ceiling; check that the temperature near the installation location is not excessive.

- Install the projector on the floor or hang it from the ceiling. Any other installation causes a malfunction such as color irregularity or a shorten lamp life.
- Do not install the unit in a location near heat sources such as radiators or air ducts, or in a place subject to direct sunlight, excessive dust or humidity, mechanical vibration or shock.
- To avoid moisture condensation, do not install the unit in a location where the temperature may rise rapidly.

### On illumination

- To obtain the best picture, the front of the screen should not be exposed to direct lighting or sunlight.
- Ceiling-mounted spot lighting is recommended. Use a cover over fluorescent lamps to avoid lowering the contrast ratio.
- Cover any windows that face the screen with opaque draperies.
- It is desirable to install the projector in a room where floor and walls are not of light-reflecting material. If the floor and walls are of reflecting material, it is recommended that the carpet and wall paper be changed to a dark color.

### On preventing internal heat build-up

After turning off the power, the cooling fan runs for about 10 minutes while the STATUS LAMP indicator flashes in green.

### Caution

The projector is equipped with ventilation holes (intake) at the front, upper side and right side, and ventilation holes (exhaust) at the rear and upper side.

Do not block or place anything near these holes, or internal heat build-up may occur, causing picture degradation or damage to the projector.

## On cleaning

- To keep the cabinet looking new, periodically clean it with a soft cloth. Stubborn stains may be removed with a cloth lightly dampened with a mild detergent solution. Never use strong solvents, such as thinner, benzene, or abrasive cleansers, since these will damage the cabinet.
- Avoid touching the lens. To remove dust on the lens, use a soft dry cloth. Do not use a damp cloth, detergent solution, or thinner.

## On repacking

Save the original shipping carton and packing material; they will come in handy if you ever have to ship your unit. For maximum protection, repack your unit as it was originally packed at the factory.

---

# Features

## High Brightness, High Picture Quality

### High brightness

The SRX-R110 uses two 2kW Xenon lamps as a light source, and the SRX-R105 uses two 1kW Xenon lamps. These compact-size Xenon lamps provide high brightness of 10,000 ANSI lumens for the SRX-R110 and 5,000 ANSI lumens for the SRX-R105, assuring excellent uniformity on the entire screen.

### High resolution

Sony's new, unique three SXRD™ (Silicon X-tal Reflective Display) panels with approximately 8,850,000 pixels realizes a high-resolution of 4096 × 2160 dots. The resolution corresponds to four times that of an HDTV image and meets the "4K" quality resolution level of Digital Cinema.

### Multi-screen mode

The high resolution of the projector enables single-, dual- and quad-mode projection in which full HD images can be displayed even in each of two or four divided screens. Images from different input sources can be displayed in these divided screens simultaneously.

### High contrast ratio

The combination of the SXRD imaging devices and 3PBS optical devices offers a high contrast ratio of more than 1800:1.

### Gamma correction circuit

Three types of gamma correction circuit, 1.8, 2.2 and 2.6, are selectable according to the signal input, allowing projection of an image with optimum brightness.

### Color space feature

The projector supports three standards of color tonal reproduction range, DCDM, 709 and CIEXYZ, allowing you to obtain an image with precise color reproduction according to the input sources.

## Flexible and Reliable System

### Dual lamp system

The projector adopts a dual lamp system for versatility of use. You can select dual-lamp or single-lamp mode, and can reduce each lamp's power output. These modes allow you to save power and increase lamp life. Also, if one bulb burns out, the other keeps projecting images.

## Versatile Setup

### Various signal input

The projector is equipped with an RS232C connector and ETHERNET connector for communication. For signal inputs, the projector has four slots to which the optional analog input boards and HD-SDI input boards can be attached according to your requirement.

### Optional lens

Four optional zoom lenses are available depending on the projection distance you are setting up. The lens shift function of this projector enables easy setup.

# Location and Function of Controls

## Front/Top

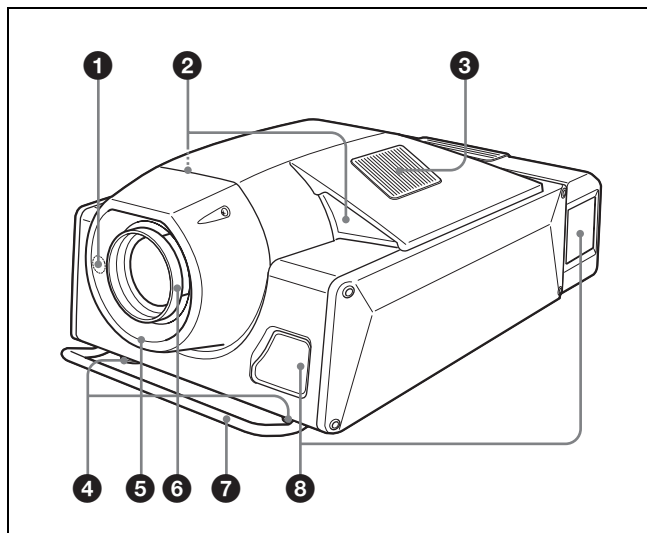

- ❶ Remote control detector (front)**
- ❷ Upper side ventilation holes (intake)**
- ❸ Upper side ventilation holes (exhaust)**
- ❹ Adjusters**  
Use to keep the projector level if it is installed on an uneven surface.
- ❺ Lens cover**
- ❻ Lens mount part**  
When attaching the optional lens, consult with qualified Sony personnel.
- ❼ Carrying handle**  
Use to carry the projector. There is another handle on the rear side.
- ❽ Front/right side ventilation holes (intake)**

## Left Side/Rear

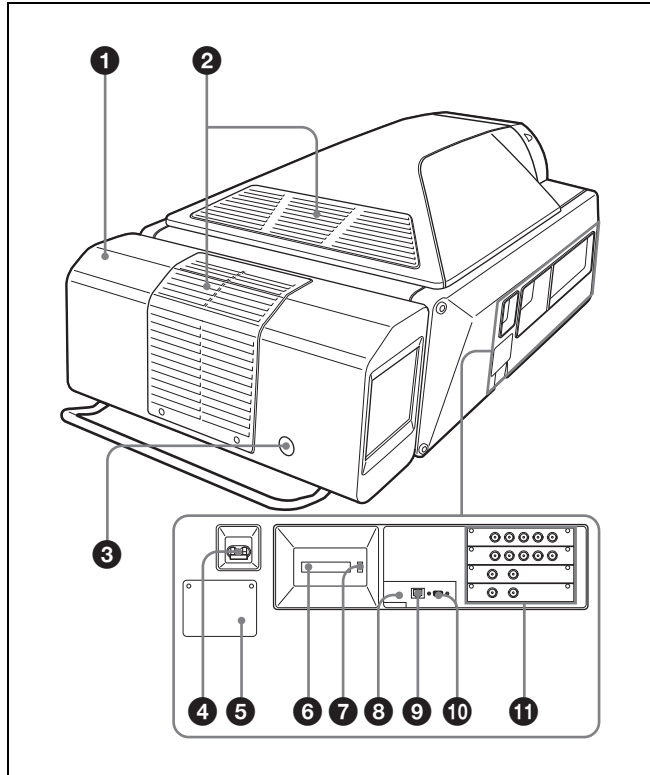

### 1 Cooling unit

A cooling fan and the two lamp houses are installed here. For replacement of the projection lamp or lamp house, consult with qualified Sony personnel.

### 2 Upper/rear side ventilation holes (exhaust)

### 3 Remote control detector (rear)

### 4 Power switch

Set the switch to the upper position to turn on the main power of the projector. To turn it off, set the switch to the lower position.

### 5 AC IN terminal board

Connect the AC power cord with three wires (not supplied). For connection of the AC power cord, contact a qualified Sony personnel.

### 6 STATUS MESSAGE window

Displays an error message. If the message is displayed, contact a qualified Sony personnel.

### 7 STATUS LAMP indicator

Lights red when the projector is in standby mode. When the power is turned on, it lights green. The indicator flashes for about 10 minutes after the power is turned off by clicking "POWER STANDBY" on the Control Function

Menu window or by pressing the button on the Remote Commander.

### 8 INTER LOCK jack (minijack)

Connects to the external emergency switch.

When you use the interlock function, insert the mini-plug into this jack to open the + and – terminals. The projector's lamps will be turned off immediately. When not in use, do not insert the mini-plug.

### 9 ETHERNET connector (10BASE-T/100BASE-TX)

Connect to the ethernet connector on a computer in which the supplied SRX Controller is installed. You can control the projector from the computer.

### 10 RS232C connector (D-sub 9-pin, female)

Connect to the RS-232C connector on a computer in which the supplied SRX Controller is installed. You can control the projector from the computer.

### 11 Input board attachment parts

Depending on the input sources, attach the optional LKRI-001 or LKRI-002 input board to each slot. They are arranged in order of INPUT A, INPUT B, INPUT C and INPUT D from the top.

*For attachment, contact a qualified sony personnel.*

## Control Function Menu Window

When you install the supplied SRX Controller in your computer, you can operate all of the features of the projector in your computer window. This section explains the functions of the parts for projecting an image on the screen.

*For the windows used for the settings and adjustments, see "Adjustments and Settings Using the SRX Controller" on page 24.*

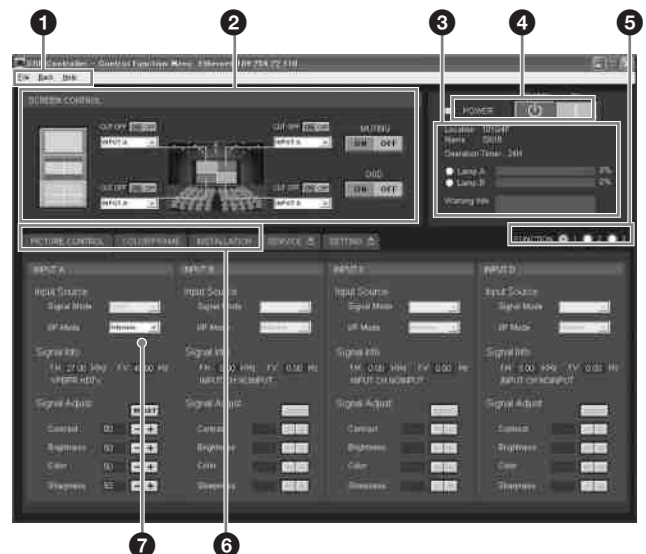



## 1 Menu bar



### File menu

Selecting “Quit” from the File menu exits the SRX Controller.

### Back menu

Click to return to the Browser Screen window of the SRX Controller.

### Password menu

Use to set the authentication passwords required for displaying the SETTING window and the SERVICE window. The Password menu can be displayed only when an authorized administrator starts the SRX Controller on the computer for controlling the projector.

*For details on the SETTING window and the SERVICE window, refer to the Installation Manual for Dealers.*

### Help menu

Shows the version information of the SRX Controller and the serial number of the projector.

## 2 SCREEN CONTROL window

*For details, see “SCREEN CONTROL window” on page 9.*

## 3 Information window

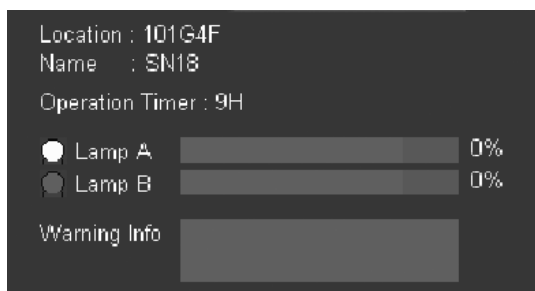

**Location:** Shows the location where the projector is installed, as set in the SETTING window at the time of installation.

**Name:** Shows the name of the projector that was set in the SETTING window at the time of installation.

**Operation Timer:** Shows the operation hours of the projector.

**Lamp A/Lamp B:** Shows an approximate percentage to indicate the time used before the recommended time for replacement of each projection lamp (i.e. 100% indicates the time for replacement). The indicator on the left lights when the corresponding lamp turns on. It does not light when the corresponding lamp turns off.

**Warning Info:** Displays an error message if there is any warning information on the projector. The same message is displayed in the STATUS MESSAGE window on the left side of the projector.

## 4 POWER ON/STANDBY (I/O) buttons and POWER indicator

Click ON to turn on the lamp. The indicator lights green. Clicking STANDBY opens the confirmation dialog. Clicking “OK” makes the projector enter standby mode. The indicator flashes green. Even in standby mode, the fans continue to run to reduce internal heat. When the fans stop running, the indicator lights red.

## 5 FUNCTION 1/2/3 radio buttons

Register the data set or adjusted with “Signal Adjust” in the PICTURE CONTROL window and “Color” in the COLOR/FRAME window. You can recall it later to project the image with that setting.

*For details, see “To register the settings that have been adjusted” on page 24.*

## 6 Window select buttons

Open the window with the items you want to set or adjust.

## 7 Adjustment/setting window

Clicking the window select button switches the window for the adjustment and setting.

The “PICTURE CONTROL,” “COLOR/FRAME” and “INSTALLATION” windows can be displayed.

*For details on each window, see “Adjustments and Settings Using the SRX Controller” on page 24.*

## SCREEN CONTROL window

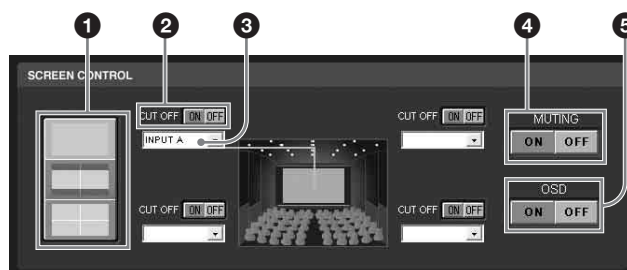

### 1 Screen mode buttons

Select single-, dual- or quad-screen mode for multiple display mode. Click for single, for dual and for quad mode.

### 2 CUT OFF “ON/OFF” buttons

Click the ON button to cut off the picture momentarily. Click the OFF button to restore the picture. The SCREEN CONTROL window changes depending on the screen mode selected with the screen mode button (1).

When dual- or quad-screen mode is selected, the buttons function independently on each divided screen.

### 3 Input signal select drop-down list box

Selects the input signal you want to project on the screen. The SCREEN CONTROL window changes depending on the screen mode selected with the screen mode button (1). When dual- or quad-screen mode is selected, you can select the input independently on each divided screen.

**INPUT A:** Selects the signal input from the connectors on the optional input board installed in the INPUT A section.

**INPUT B:** Selects the signal input from the connectors on the optional input board installed in the INPUT B section.

**INPUT C:** Selects the signal input from the connectors on the optional input board installed in the INPUT C section.

**INPUT D:** Selects the signal input from the connectors on the optional input board installed in the INPUT D section.

### 4 MUTING ON/OFF buttons

Clicking the ON button cuts off the whole picture on the screen momentarily. Click the OFF button to restore the picture. Activating the muting function blocks off lamp light completely by use of a shutter, and displays the black signal on the whole screen.

### 5 OSD ON/OFF buttons

Click the OFF button to eliminate the on-screen display. Click the ON button to display it on the screen. The setting using the buttons also functions when you operate the projector with the Remote Commander.

## Remote Commander

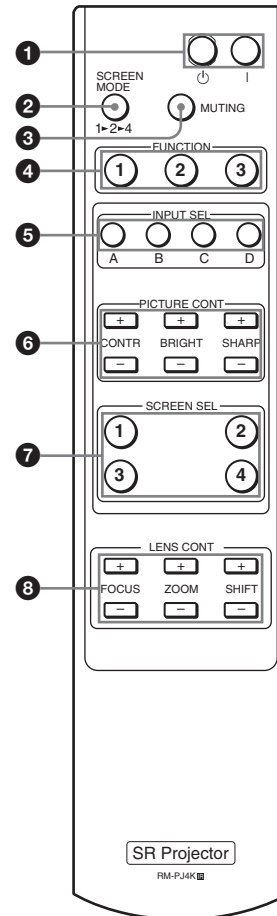

### 1 I/O (power on/standby) buttons

I: Press to turn on the projector.

⏻: Press to make the projector enter standby mode.

### 2 SCREEN MODE button

Selects single-, dual- or quad-screen. Each press of the button changes the mode, 1 (single), 2 (dual) and 4 (quad), in this order.

### 3 MUTING button

Press to cut off the whole picture on the screen. Press it again to restore the picture. Activating the muting function shuts off from lamp light completely using a shutter, and displays the black signal on the whole screen.

### 4 FUNCTION 1/2/3 buttons

Use these buttons in synchronization with the FUNCTION buttons in the Control Function Menu window of the SRX Controller. You can recall the data set or adjusted with the SRX Controller.

### 5 INPUT SEL A/B/C/D buttons

Select the input source you want to project or operate.

- A:** Selects the signal input from the connectors on the optional input board installed in the INPUT A section.
- B:** Selects the signal input from the connectors on the optional input board installed in the INPUT B section.
- C:** Selects the signal input from the connectors on the optional input board installed in the INPUT C section.
- D:** Selects the signal input from the connectors on the optional input board installed in the INPUT D section.

Use these buttons together with the PICTURE CONT buttons (6) or SCREEN SEL buttons (7).

**Example:** When you want to increase the contrast of the signal input from the INPUT A board, press INPUT SEL A button, then press the CONTR + button.

### 6 PICTURE CONT (Picture control) buttons

Adjust the projected picture quality.

**CONTR +/-:** Adjust the contrast. Pressing the + button increases the contrast. Pressing the – button decreases the contrast.

**BRIGHT +/-:** Adjust the picture brightness. Pressing the + button makes the picture brighter. Pressing the – button makes the picture darker.

**SHARP +/-:** Adjust the picture sharpness. Pressing the + button makes the picture sharper. Pressing the – button makes the picture softer.

In multiple screen mode, adjustment can be made for the input signal from each input board.

Select the input signal with the INPUT SEL A/B/C/D buttons (5), then adjust the picture with these buttons. In single-screen mode, you need not press the INPUT SEL button.

**Example:** When you want to increase the contrast for the signal input from the INPUT A board, press the INPUT SEL A button, then press the CONTR + button.

### 7 SCREEN SEL buttons

In multiple screen mode, select one of the divided screens where you want to project the selected signal from each input board.

Select the input signal with one of the INPUT SEL A/B/C/D buttons (5), then select the screen with one of these buttons.

**Example:** When you want to project the signal input from the INPUT B board on Screen 3 (lower left screen), press the INPUT SEL B button, then press the SCREEN SEL 3 button.

### 8 LENS CONT buttons

**FOCUS +/-:** Adjust the focus. Pressing the + button focuses on a forward picture. Pressing the – button focuses on a picture further back.

**ZOOM +/-:** Adjust the picture size. Pressing the + button enlarges the picture size. Pressing the – button reduces the picture size.

**SHIFT +/-:** Adjust the vertical picture position. Pressing the + button moves the picture upward. Pressing the – button moves the picture downward.

## To install batteries

- 1 Remove the lid, then install the two size AA (R6) batteries (supplied) with the correct polarity.

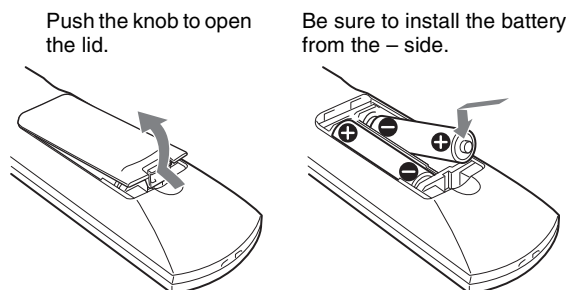

- 2 Replace the lid.

### Notes

- Be sure that there is nothing to obstruct the infrared beam between the Remote Commander and the projector. Direct the Remote Commander toward one of the remote control detectors at the front and rear of the projector when operating.
- The operation range is limited. The shorter the distance between the Remote Commander and the projector, the wider the angle within which the Commander can control the projector.

## Precautions on Installation

### Unsuitable Installation

Do not install the projector in the following situations. Such installations may cause a malfunction or damage to the projector.

#### Poorly ventilated

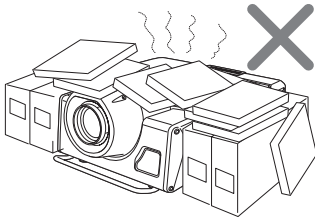

The projector is equipped with ventilation holes for intake and exhaust to prevent internal heat build-up. Do not place the projector in a place where the ventilation holes may be blocked.

#### Situation that may block the ventilation holes for exhaust

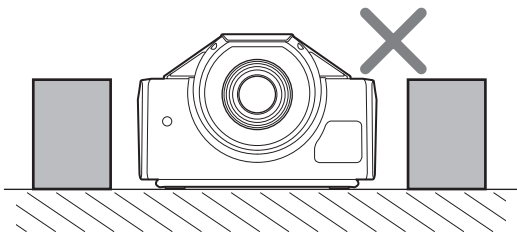

If you put something beside the ventilation holes for exhaust on the side or rear of the projector, the exhaust may be inhaled into the projector through the ventilation holes for intake, causing internal heat build-up and thereby

activating the protection circuit. Be sure not to block the ventilation holes for exhaust. Leave a space of more than 1 m (39 <sup>3</sup>/<sub>8</sub> inches) around the unit.

#### Extremely hot and humid

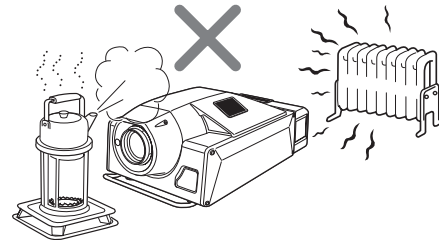

#### Location subject to sudden change of temperature

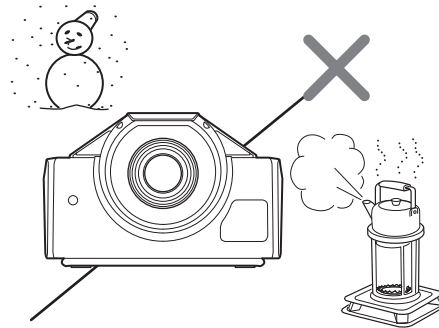

A sudden change of temperature may produce moisture condensation, causing damage to the projector. Take care with heaters or air-conditioners.

#### Very dusty

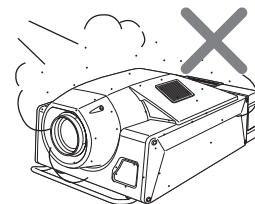

## Unsuitable Conditions

Do not use the projector under the following conditions.

### Laying the unit on its side or upside down

### Tilting the unit to the right or left

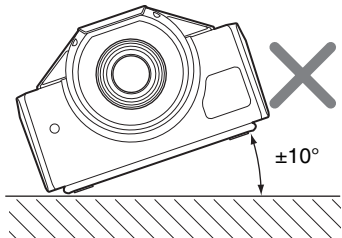

Avoid tilting the projector more than  $\pm 10$  degrees, and avoid installing it in place other than a floor. Doing so may cause color shading or shorten the lamp life excessively.

### Blocking the ventilation holes

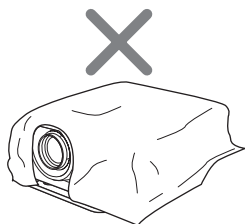

Avoid using a thick-piled carpet or anything that covers the ventilation holes (exhaust/intake). Otherwise, internal heat may build up.

*For the locations of the ventilation holes (exhaust/intake), see “Location and Function of Controls” on page 7.*

## Installation

### Using the Carrying Handles

Use the front and rear carrying handles to carry the projector.

#### Caution

To avoid injury, have at least four people carry the projector using the front and rear handles.

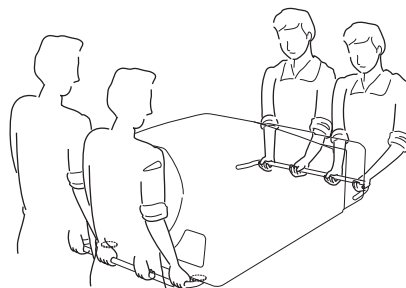

### Using the Adjusters

When the projector installation location is not horizontal, rotate the adjusters using a spanner so that the projector is placed horizontally. There are an adjuster on the right and one on the left.

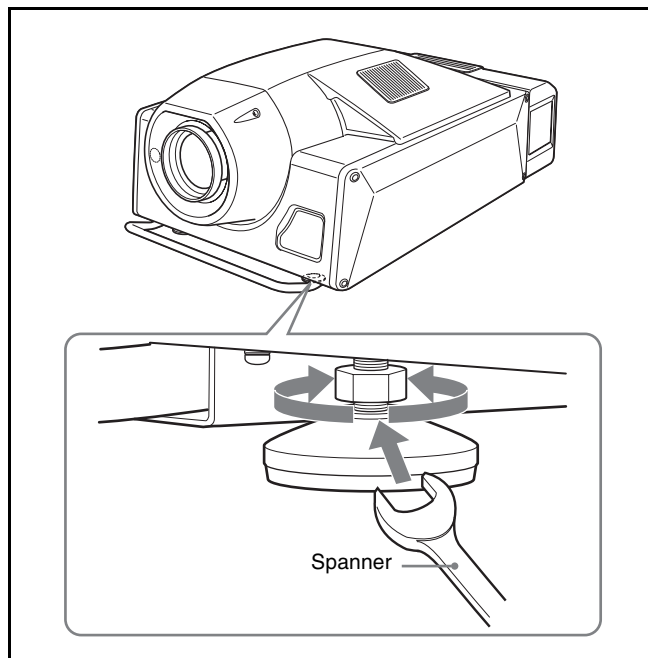

**Caution**

Do not turn the spanner forcibly when the screw has fully rotated. Otherwise, the spanner may slip and injure your hand.

## Installing the Projector

This section describes briefly how to install the projector on the floor. The distance between the center of the lens and the screen varies depending on the optional lens attached, the horizontal screen size or the input signal.

For details on installation examples with projection distances, see “Installation Manual for Dealers.”

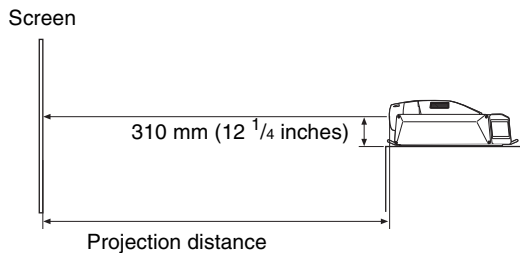

### Vertical positioning (side view)

Install the projector so that the center of the lens is between the bottom edge and the top edge of the screen. You can move the picture position vertically by half of the screen vertical size using the lens shift adjustment.

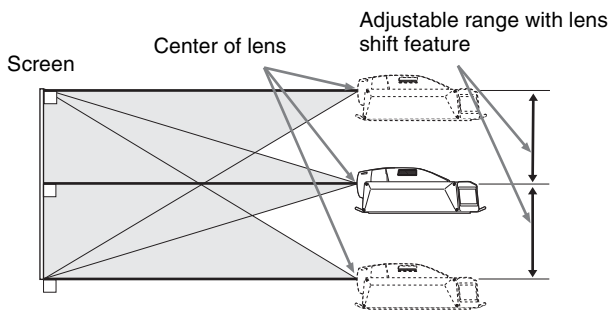

### Horizontal positioning (top view)

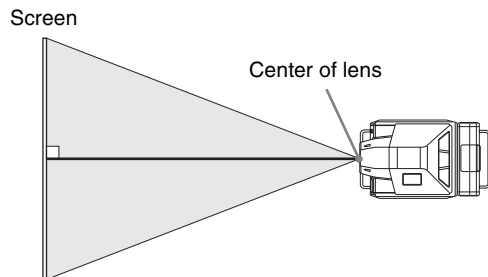

# Installing the SRX Controller in a Computer for Controlling the Projector

If you install the supplied SRX Controller in a computer, you can control the projector from the computer.

## System Requirements

The following are required to operate the supplied SRX Controller.

- Computer: Intel Celeron CPU, 1 GHz or more
  - Installed memory: 256 MB or more
  - Communication: 10BASE-T/100BASE-TX
  - VGA: XGA (1024 × 768) or higher
  - HDD: Connected to a computer via the IDE port, Usable memory with 8 MB or more
  - CD-ROM drive: × 8 or faster
- Operating System: Microsoft Windows XP Professional SP2 (English or Japanese version)

## Installing the SRX Controller

- 1 Insert the supplied installation disc into the CD-ROM drive of a computer.

The setup.exe in the root folder of the installation disc starts, and the window for preparing the installation appears.

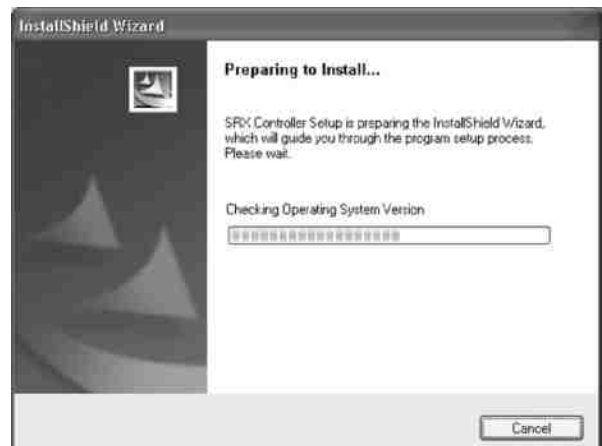

After a while, the Welcome page of the SRX Controller appears.



**2** Click “Next.”

The License Agreement window appears.



**3** Read the license agreement, click “I accept...” if you agree to be bound by the terms, and click “Next.”

The select window of the destination folder in which to install the SRX Controller appears.



When you want to install it in the currently displayed folder, click “Next.”

If you want to install it in a different folder, click “Change...,” specify the folder, click “OK,” then click “Next.”

The installation start window appears.



**4** Click “Install.”

The program installation starts.

After a while, the following window appears.

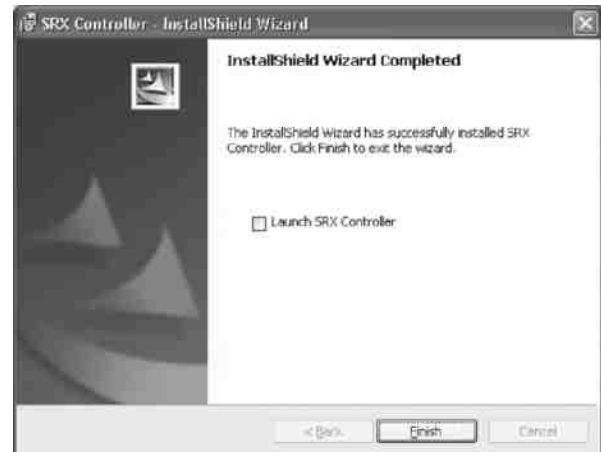

**5** Click “Finish.”

Installation of the SRX Controller is completed. To restart the SRX Controller immediately after installation has been completed, click to check “Launch SRX Controller,” then click “Finish.”

The  icon is displayed in the desktop window.



# Connecting a Computer for Controlling the Projector

Connect a computer for controlling the projector to the projector via the ETHERNET connector or the RS232C connector.

## Connecting the Computer via the Ethernet

Connect the computer to the projector using the supplied ethernet cable (cross cable).

### Note

Set the TCP/IP protocol of the connected computer to DHCP.

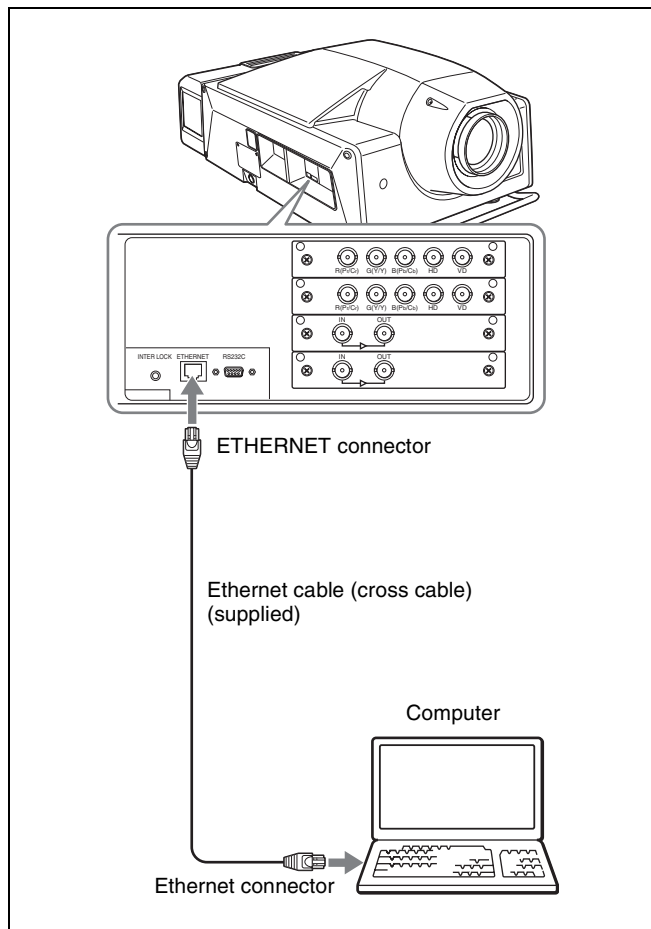

### CAUTION

For safety, do not connect the connector for peripheral device wiring that might have excessive voltage to this port. Follow the instructions for this port.

### Note

If the power of the projector remains on for a long period of time without the Ethernet cable connected, the message "Sony SR Projector Initializing..." may appear in the STATUS MESSAGE window while you are setting up for networking after connecting the Ethernet cable. This is not a malfunction of the projector.

## Connecting the Computer via the RS-232C

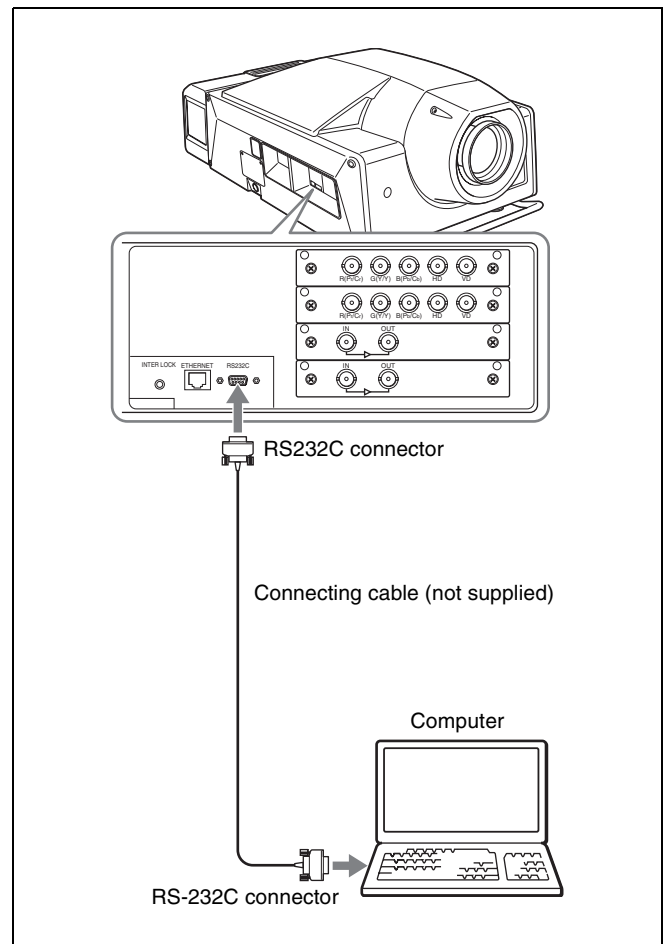



# Starting the SRX Controller

## Starting the SRX Controller

Double-click the  icon for the SRX Controller in the desktop window of the computer.

The SRX Controller starts and the Browser Screen is displayed.

## About the Browser Screen



### 1 Menu bar

#### File

Select “Quit” from the File menu to exit the SRX Controller.

#### Connect

Selects the connection mode between the projector and the computer for controlling the projector.

For details, see “Changing the Connection Mode” on page 17.

#### Help

Select “Version” from the Help menu to display the version information of the SRX Controller.

### 2 Select button

Selecting the projector displayed in the projector detect window and then clicking this button opens the Control Function Menu window of the selected projector.

### 3 Refresh button

Updates all of information on the projectors displayed in the projector detect window.

### 4 EMERGENCY STANDBY button

Clicking the button makes the projectors indicated by “Connectable” under “Connection” in the projector detect window enter standby mode. The fans continue to run.

### 5 Projector detect window

Information on all of the projectors connected to a network is displayed.

The following information is shown:

**Alert:** Shows whether there is any warning information on the projector or not. (■: Yes, □: No)

**Model Name:** Model name of the projector

**Serial No.:** Serial number of the projector

**IP Address:** IP address of the projector

**Connection:** Network connection status of the projector

The projectors that can be selected with the Select button are indicated by “Connectable” under “Connection.”

**Power:** Power on/off status of the projector

**Region:** Region where the projector is installed

**Location:** Installation location of the projector

**Name:** Free name

## To exit the SRX Controller

Click “Quit” from the File menu on the menu bar.

## Changing the Connection Mode

When the projector you want to operate is connected to the computer via a network, you can also select it by specifying the IP address of the projector. Connection via the RS-232C is also available.

### When connecting the computer via a network by specifying the IP address of the projector

Select “Ethernet” from the Connect menu on the menu bar to open the dialog. Enter the IP address of the projector, then click “OK.”

To change the port number, select “PC Port Setting” from the Connect menu on the menu bar to display the dialog. Enter the new port number in the dialog and click “OK.”

### When connecting the computer via RS-232C

Select “RS232C” from the Connect menu on the menu bar to open the dialog. Enter the port number of the COM port (RS-232C) for the computer, then click “OK.”

## Connecting the Projector

### When you connect the projector, make sure to:

- Turn off all equipment before making any connections.
- Use the proper cables for each connection.
- Insert the cable plugs firmly; loose connections may increase noise and reduce performance of picture signals. When pulling out a cable, be sure to pull it out from the plug, not the cable itself.
- When installing the optional input board, consult with the Sony dealer.

Refer also to the instruction manuals of the equipment to be connected.

## Connecting with HD-SDI Equipment

Attach the optional LKRI-002 HD-SDI (4:2:2) input board to the input board attachment part on the projector, and connect the HDCAM recorder/player.

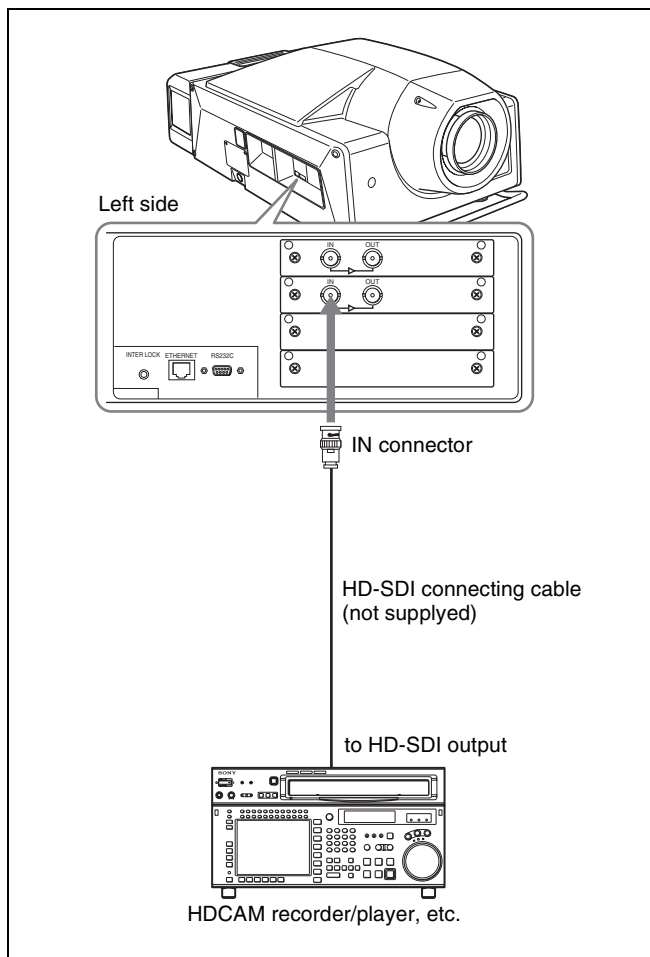

## Connecting with Component/Video GBR Equipment

Attach the optional LKRI-001 analog input board to the input board attachment part on the projector, and connect with a DVD recorder/player or analog video equipment equipped with the component output, or an high-definition equipment equipped with a video GBR connector.

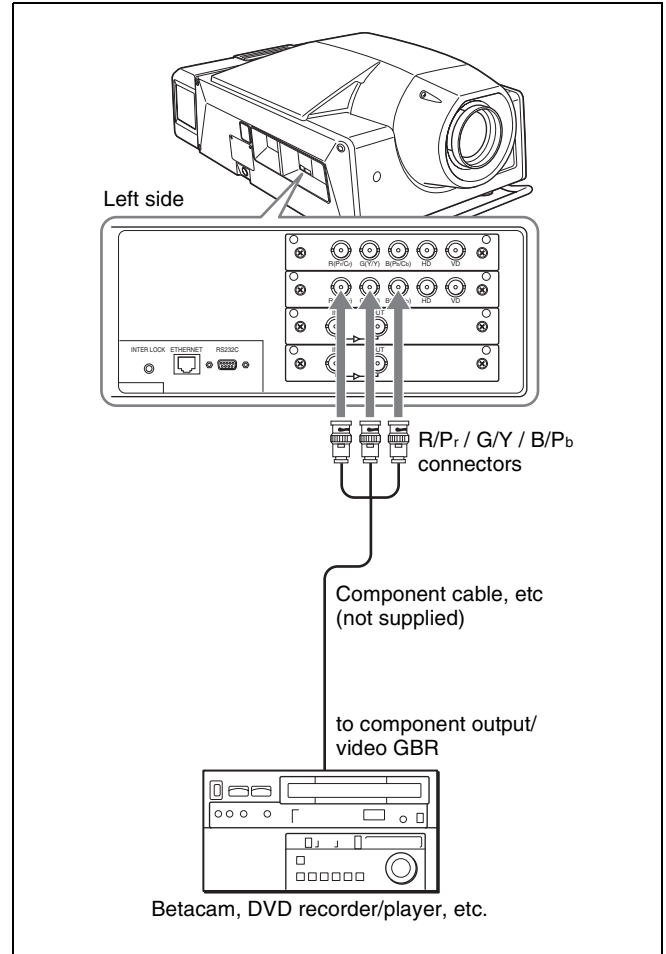

### Note

When connecting to the output of HD component equipment, set "Signal Mode" of "Input Source" in the PICTURE CONTROL window to "Y/Pb/Pr," and when connecting to the output of HD video GBR equipment, set to "RGB."

For details, see page 25.

## Connecting with a Computer

Attach the optional LKRI-001 analog input board to the input board attachment part on the projector, and connect with a computer.

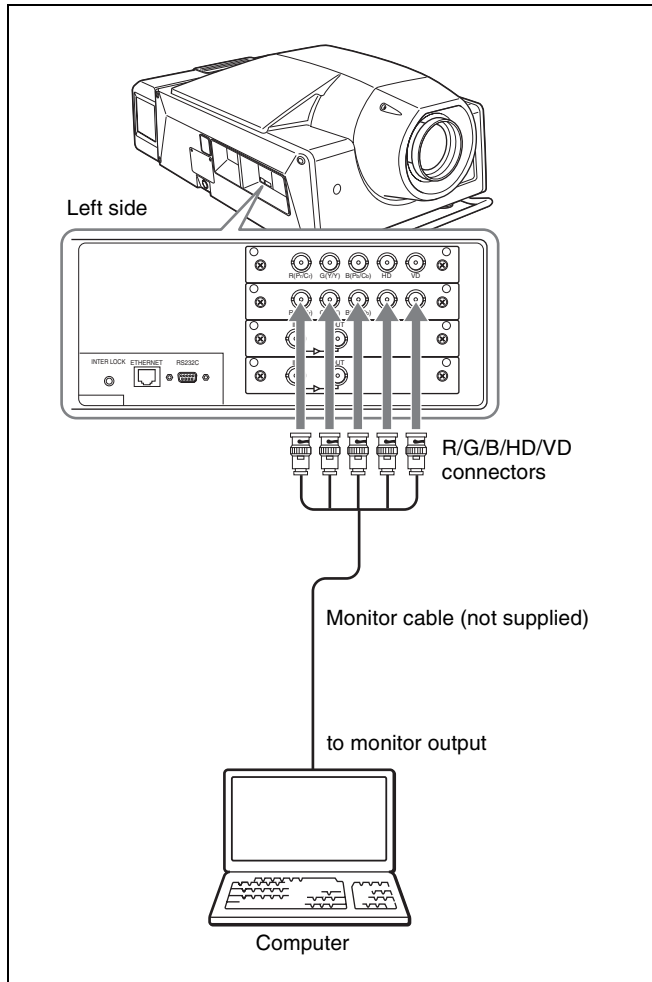

**Note**

Select “RGB” in “Signal Mode” of “Input Source” in the PICTURE CONTROL window.

*For details, see page 25.*

## Projecting the Picture

Use the supplied Remote Commander or a computer in which the supplied SRX Controller is installed to project the picture on the screen.

## Using the Remote Commander

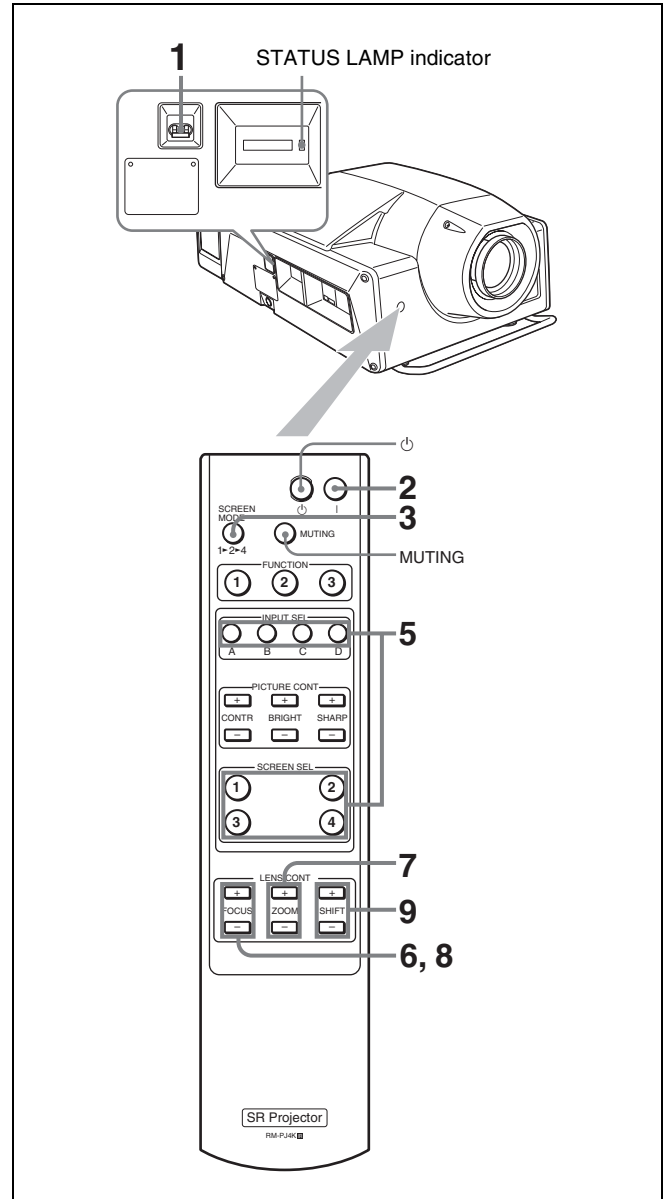

- 1** Set the main power switch on the left side of the projector to the upper position.  
The STATUS LAMP indicator lights red and the projector goes into standby mode.
- 2** Press the **I** button to turn on the projector.  
The STATUS LAMP indicator lights green.
- 3** Select the screen mode.  
Each time you press the SCREEN MODE button, the screen mode switches as follows:
  - 1 (single-screen mode):** Projects an image in full screen.
  - 2 (dual-screen mode):** Projects images in two divided screens. You can also project a different input source in each of the two screens.
  - 4 (quad-screen mode):** Projects images in four divided screens. You can also project a different input source in each of the four screens.
- 4** Turn on the equipment connected to the projector.
- 5** Press the INPUT SEL button to select the input source.
  - A:** to select the input source from the equipment connected to the optional input board attached to the INPUT A section.
  - B:** to select the input source from the equipment connected to the optional input board attached to the INPUT B section.
  - C:** to select the input source from the equipment connected to the optional input board attached to the INPUT C section.
  - D:** to select the input source from the equipment connected to the optional input board attached to the INPUT D section.

#### When you select “dual-screen mode” or “quad-screen mode” in step 3

Press one of the INPUT SEL A to D buttons to select the input source you want to project, then select one of the divided screens where you want to project the picture with the SCREEN SEL button.

#### Note

When projecting moving pictures in multiple screens, all the input signals should be genlocked to synchronize with each other. A picture on the left screen for dual-screen mode or that on the upper left screen for quad-screen mode is regarded as a reference picture. The projected moving picture not synchronized with the reference picture appears incompatible with the moving pictures projected on other screens. If you project still pictures and moving pictures together, select the left screen for the moving

picture in dual-screen mode or the upper left screen in quad-screen mode. If you project still pictures only, you may project them on any screen.

- 6** Adjust the focus with the FOCUS +/- buttons.  
During adjustment, “FOCUS” appears on the screen.
- 7** Adjust the picture size with the ZOOM +/- buttons.  
During adjustment, “ZOOM” appears on the screen.
- 8** Adjust the focus again with the FOCUS +/- buttons.
- 9** Adjust the vertical position of the picture with the SHIFT +/- buttons.  
During adjustment, “SHIFT” appears on the screen.

#### Note

The FOCUS, ZOOM and SHIFT indications do not appear when you select “OSD OFF” in the Control Function Menu window of the computer.

#### To cut off the picture

Press the MUTING button.

To restore the picture, press the MUTING button again.

#### To turn off the power

- 1** Press the  button.

The STATUS LAMP indicator flashes green and the fan continues to run for 10 minutes to reduce the internal heat. When the fan stops running, the STATUS LAMP indicator lights red.

- 2** Set the main power switch to the lower position.

#### Note

Do not set the main power switch to the lower position while the fan is running. Doing so stops the fan before the inside of the projector has been cooled down sufficiently and may damage the unit.

## Using the Computer for Controlling the Projector

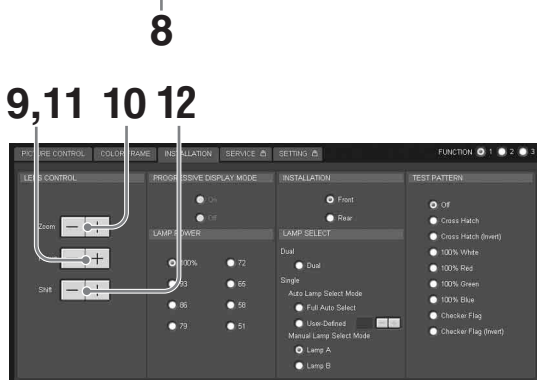
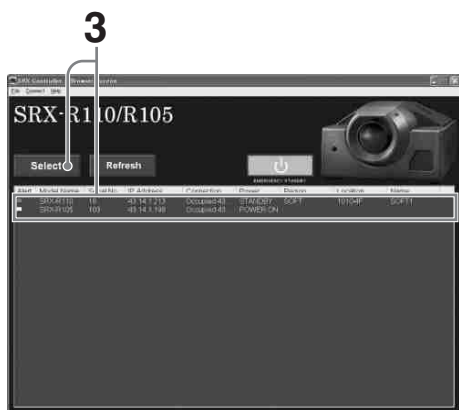
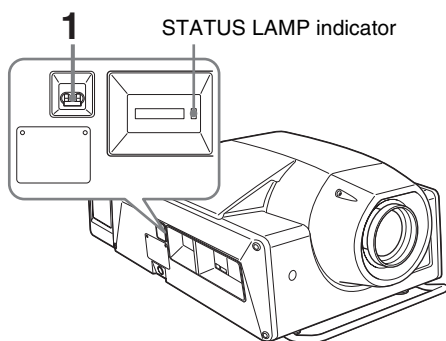

- 1 Set the main power switch on the left side of the projector to the upper position.

The POWER and STATUS LAMP indicators light red and the projector goes into standby mode.

- 2 Start your computer and double-click the  icon of the SRX Controller in the desktop window.

The Browser Screen of the SRX Controller opens.

- 3 Select the projector you want to operate by double-clicking the projector or by pointing at it and clicking the Select button.

The Control Function Menu window opens.

### Note

When you connect the projectors to the computer via a network, you can also select the projector you want to operate by specifying the IP address of the projector. If connection is made via the RS232C connector on the projector, specify the RS-232C port number of the computer.

For details, see “Changing the Connection Mode” on page 17.

- 4 Click the POWER ON I button to turn on the projector.

The POWER and STATUS LAMP indicators light green.

- 5 Click one of the following buttons to select the screen mode.

 (single screen mode): Projects images in full screen.

 (dual screen mode): Projects images in two divided screens. You can also project a different input source in each of the two screens.

 (quad screen mode): Projects images in four divided screens. You can also project a different input source in each of the four screens.

- 6 Turn on the equipment connected to the projector.

- 7 Select the input source from the drop-down list box displayed by clicking .

**INPUT A:** to select the input source from the equipment connected to the optional input board attached to the INPUT A section.

**INPUT B:** to select the input source from the equipment connected to the optional input board attached to the INPUT B section.

**INPUT C:** to select the input source from the equipment connected to the optional input board attached to the INPUT C section.

**INPUT D:** to select the input source from the equipment connected to the optional input board attached to the INPUT D section.

**Note**

When you select the input from the connectors on the LKRI-001 input board, select the appropriate input signal from “Signal Mode” of “Input Source” in the PICTURE CONTROL window. Improper setting may cause deterioration of the picture.

*For details, see page 25.*

**When you select “dual-screen mode” or “quad-screen mode” in step 5**

Select the input source for each screen from the corresponding drop-down list box.

**Note**

When projecting moving pictures in multiple screens, all the input signals should be genlocked to synchronize with each other. A picture on the left screen for dual-screen mode or that on the upper left screen for quad-screen mode is regarded as a reference picture. The projected moving picture not synchronized with the reference picture appears incompatible with the moving pictures projected on other screens. If you project still pictures and moving pictures together, select the left screen for the moving picture in dual-screen mode or the upper left screen in quad-screen mode. If you project still pictures only, you may project them on any screen.

- 8 Click the “INSTALLATION” button to open the INSTALLATION window.
- 9 Adjust the focus with the Focus +/- buttons.  
During adjustment, “FOCUS” appears on the screen.
- 10 Adjust the picture size with the Zoom +/- buttons.  
During adjustment, “ZOOM” appears on the screen.
- 11 Adjust the focus again with the Focus +/- buttons.
- 12 Adjust the vertical position of the picture with the Shift +/- buttons.  
During adjustment, “SHIFT” appears on the screen.

**Note**

The FOCUS, ZOOM and SHIFT indications do not appear when you select “OSD OFF” in the SCREEN CONTROL window.

**To cut off the picture**

Click “ON” of the CUT OFF buttons.  
When you select the dual-screen mode or quad-screen mode, you can cut off the picture of each screen

independently. Click “ON” of the CUT OFF buttons of each screen.

To restore the picture, click “OFF” of the CUT OFF buttons.

**To cut off the whole screen**

Click the MUTING ON button. The whole screen appears in black. To restore the picture, click the MUTING OFF button.

**To turn off the power**

- 1 Click the POWER STANDBY  button, then the OK button in the displayed confirmation dialog.

The POWER and STATUS LAMP indicators flash green and the fan continues to run for 10 minutes to reduce the internal heat. When the fan stops running, the POWER and STATUS LAMP indicators light red.

- 2 Set the main power switch to the lower position.

**Note**

Do not switch the main power switch to the lower (off) position while the fan is running. Doing so stops the fan before the inside of the projector has been cooled down sufficiently and may damage the unit.

## Displaying the Control Function Menu Window

When you install the supplied SRX Controller in a computer, you can operate the picture adjustments, input signal settings, installation settings, etc. from the computer.

Some of the picture adjustments are available using the supplied Remote Commander.

For details, see “Remote Commander” on page 10.

- 1 Double-click the  icon of the SRX Controller in the desktop window of the computer.

The Browser Screen appears.

- 2 Select the projector you want to operate by double-clicking the projector or click the Select button.

The Control Function Menu window opens.

- 3 Click any of the PICTURE CONTROL, COLOR/FRAME and INSTALLATION buttons to display the desired control window.

For details on each setting window, see the relevant window pages.

### To go back to the Browser Screen

Select “Back” on the menu bar.

### To clear the Control Function Menu window

Select “Quit” from the File menu on the menu bar, or click the  (close) button.

### To reset the settings that have been adjusted

Clicking the RESET button in the PICTURE CONTROL window resets all the settings of the items for “Signal Adjust” to their factory preset values. To reset the settings of the items for “Frame Adjust” in the COLOR/FRAME window, click the RESET button in the COLOR/FRAME window.

### To register the settings that have been adjusted

You can register the settings that have been adjusted with “Signal Adjust” and “Color” in the control windows to FUNCTION 1, 2 and 3. As the default setting, the settings are registered to FUNCTION 1. To register the settings to FUNCTION 2 or 3, click the FUNCTION 2 or 3 radio button, then adjust the items in each window.

You can recall it later to project the picture with the desired setting by clicking one of the FUNCTION radio buttons. You can also recall it with the FUNCTION 1, 2 or 3 button on the Remote Commander.





## About the items that cannot be adjusted

Items that cannot be adjusted depending on the input signal are not displayed in the window.

For details, see “Input Signals And Adjustable/Setting Items” on page 29.

# PICTURE CONTROL Window

The PICTURE CONTROL window is used to select the input source or to adjust the picture quality. When the screen mode is set to “dual screen” or “quad screen,” the items can be independently adjusted for each input channel displayed on the screen.

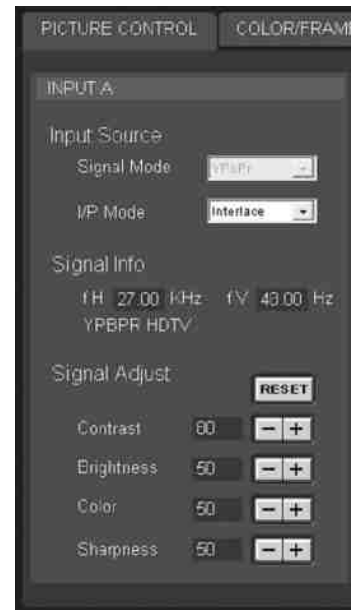

## Input Source

**Signal Mode:** Click  to select the type of signal from the drop-down list when a high-definition signal is input from equipment connected to the optional LKRI-001 input board. Select “YPbPr” to input the high-definition signal from component equipment, and “RGB” to input the high-definition signal from video GBR equipment.

**I/P Mode:** Selects the I/P conversion mode. Depending on the input signal source, set the mode to “Interlace” or “PsF.”

## Signal Info (Information)

Shows the horizontal and vertical frequencies of the input signal automatically. The values are approximate. The type of the input signal is also displayed.

**fH:** Displays the horizontal frequency.

**fV:** Displays the vertical frequency.

## Signal Adjust

Adjusts the picture quality of the input signal.

Clicking **+** increases the setting value, and **-** decreases it.

Clicking the RESET button resets all the settings to the factory preset values.

**Contrast:** Adjusts the picture contrast. The higher the setting, the greater the contrast.

**Brightness:** Adjusts the picture brightness. The higher the setting, the brighter the picture.

**Color:** Adjusts the color intensity. The higher the setting, the greater the intensity.

**Sharpness:** Adjusts the picture sharpness. The higher the setting, the sharper the picture. The lower the setting, the softer the picture.

## COLOR/FRAME Window

The COLOR/FRAME window is used to adjust the input signal.

When the screen mode is set to “dual-screen” or “quad-screen,” the items can be independently adjusted for each input channel displayed on the screen.

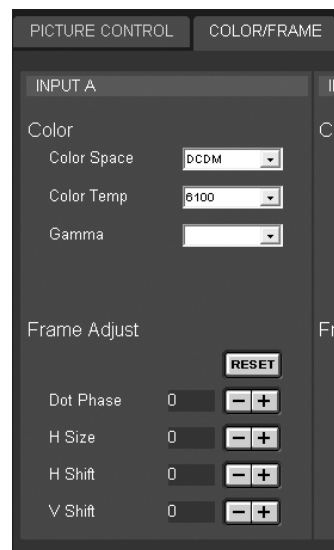

### Color

Adjusts the items so that you can obtain precise color reproduction.

If the color of an image is not correct, check the setting of “Color Space” first.

Select the setting from the drop-down list displayed by clicking **▼**.

**Color Space:** Selects the color gamut.

709: Select when projecting a normal high-definition signal or RGB signal.

DCDM: Select when projecting a special source such as a movie.

CIEXYZ: This item is for future use.

**Color Temp (temperature):** Selects the color temperature from among “DCI W/P,” “6500,” “CUSTOM1,” “CUSTOM2,” “CUSTOM3” and “CUSTOM4.” “DCI W/P” is preset in CUSTOM1 to 4 settings in the factory.

“6500” is recommended for a normal high-definition signal or RGB signal. Set this item to “DCI W/P” to project a movie source.

**Gamma:** Selects a gamma correction curve from among “2.6,” “2.2” and “1.8.”

The smaller the value, the brighter the image. Select the setting depending on the signal source. “2.2” is recommended to project a normal high-definition signal or RGB signal.

## Frame Adjust

Adjusts the horizontal size and the position of the picture. Clicking **+** increases the setting value, and **-** decreases it.

Clicking the RESET button resets all the settings of “Frame Adjust” to the factory-preset values.

**Dot Phase:** Adjusts the phase of the SXRD panels and the input signal. Adjusts the value to obtain the clearest picture.

**H Size:** Adjusts the horizontal size of the picture according to the input signal. As the setting value increases, the horizontal size of the picture becomes larger.

**H Shift:** Adjusts the horizontal position of the picture. As the setting value increases, the picture moves to the right. As the value decreases, the picture moves to the left.

**V Shift:** Adjusts the vertical position of the picture. As the setting value increases, the picture moves up. As the value decreases, the picture moves down.

### Notes

- Adjustment of “Dot Phase” and “H Size” is available for computer signal input only.
- If the position of the picture is not adjusted correctly, noise may appear in the blank portion of the screen. This is not a malfunction of the projector. Adjust the picture position correctly with “Frame Adjust.”

## INSTALLATION Window

The INSTALLATION window is used to adjust the projected picture, change the lamp output, etc.



## LENS CONTROL

Adjusts the projected picture on the screen.

**Zoom +/-:** Adjusts the size of the picture. Clicking **+** enlarges the picture size, and **-** reduces the picture size.

**Focus +/-:** Adjusts the picture focus. Clicking **+** focuses on a forward picture. Clicking **-** focuses on a picture further back.

**Shift +/-:** Adjusts the vertical position of the picture. Clicking **+** moves the picture upward. Clicking **-** moves it downward.

## PROGRESSIVE DISPLAY MODE

Normally, click the Off radio button.

Click the On radio button when four HD images with 2048 (1920) × 1080 pixels are input from four HD-SDI input boards and are combined into a 4096 (3840) × 2160-pixel image on the screen in “quad-screen” mode.

## LAMP POWER

Adjusts the lamp power output. You can reduce the lamp power to 93%, 86%, 79%, 72%, 65%, 58% or 51%. The brightness of the projected image will be darker, but power consumption can be reduced and this increases the lamp life. Clicking the 100% radio button allows you to obtain the brightest projection image.

### Note

Switching the lamp output frequently may reduce the lamp life. Use of the defined lamp output is recommended.

---

## INSTALLATION

Selects how to install the projector.

**Front:** Selects front projection.

**Rear:** Selects rear projection.

---

## LAMP SELECT

Selects whether to use one of two lamps or both lamps.

**Dual:** Select if you want to use two lamps.

**Single:** Select if you want to use only one of two lamps. In this setting, you can further select the lamp to be used automatically or manually.

### Auto Lamp Select Mode

When you click the Full Auto Select radio button, the lamp with fewer used hours is automatically turned on. When you use the projector for a long period of time, click the User-Defined radio button. If you specify the hour between 4 and 24 hours by clicking the **+** / **-** buttons, the two lamps turn on alternately at the interval of the specified hours.

### Manual Lamp Select Mode

You can specify the lamp to be used by clicking the Lamp A or Lamp B radio button.

#### Note

If you switch “LAMP SELECT” from “Single” to “Dual” or when either Lamp A or Lamp B switches to turn on, the projected image will be cut off momentarily.

---

## TEST PATTERN

Displays a built-in test pattern on the screen for adjusting the picture with no signal input from external equipment. Click the radio button of the desired test pattern from among “Cross Hatch,” “Cross Hatch (Invert),” “100% White,” “100% Red,” “100% Green,” “100% Blue,” “Checker Flag” and “Checker Flag (Invert).” When you do not display a built-in test pattern, click the Off radio button.

#### Note

While a built-in test pattern is displayed on the screen, you cannot change the screen mode and input select mode, and cannot adjust the “PICTURE CONTROL” and “COLOR FRAME.”

# Input Signals And Adjustable/Setting Items

Some items of “Signal Adjust” in the PICTURE CONTROL window and “Frame Adjust” in the COLOR/FRAME window are not adjusted or set depending on the input signals. Items that cannot be adjusted depending on the input signal are not displayed in the window.

## Signal Adjust

Item	Input signal			
	Component	Video GBR	Computer	HD-SDI
Contrast	●	●	●	●
Brightness	●	●	●	●
Color	●	–	–	●
Sharpness	●	●	●	●

- : Adjustable/can be set
- : Not adjustable/cannot be set

## Frame Adjust

Item	Input signal			
	Component	Video GBR	Computer	HD-SDI
Dot Phase	–	–	●	–
H Size	–	–	●	–
H Shift	●	●	●	●
V Shift	●	●	●	●

- : Adjustable/can be set
- : Not adjustable/cannot be set

---

## **Lamp Life**

Recommended time for replacement of the projection lamp is as follows:

SRX-R110: Approx. 800 hours

SRX-R105: Approx. 1,000 hours

The “Lamp A” and “Lamp B” bar indicators in the Control Function Menu window become red when the time for replacement is coming near. The percentage indicates the time used before the recommended time for replacement. Use them as a guide.

Be sure to ask qualified Sony personnel to replace a projection lamp and lamp house.

# Troubleshooting

If the projector appears to be operating erratically, try to diagnose and correct the problem using the following guide. If the problem still persists, consult with qualified Sony personnel.

## Power

Symptom	Cause	Remedy
Power is not turned on.	The main power is turned off.	Set the power switch on the projector to the upper position (pages 21 and 22).
	The projector and a computer for controlling the projector are disconnected.	Connect the projector and a computer properly (page 16).
	The cooling unit is detached.	Consult with qualified Sony personnel after the second time.

## Picture

Symptom	Cause	Remedy
No picture.	Cables are disconnected.	Check that the proper connection has been made (page 18).
	Input selection is not correct.	Select the input source correctly in the SCREEN CONTROL window (page 22).
	The picture is cut off.	Click the MUTING OFF or CUT OFF ON button in the SCREEN CONTROL window (page 23), or press the MUTING button on the Remote Commander (page 21).
	Ambient temperature is high.	Reduce the room temperature so that it becomes within the operating temperature (5–35°C).
Color balance is incorrect.	Incorrect input source mode is selected.	Set “Signal Mode” of “Input Source” in the SCREEN CONTROL window correctly (page 25).
The picture is too dark.	Contrast and brightness has not been adjusted properly.	Adjust the contrast or brightness in the PICTURE CONTROL window (page 26), or adjust them using the CONTR or BRIGHT button on the Remote Commander (page 11).
	Lamp mode is not properly selected.	Set “LAMP POWER” or “LAMP SELECT” in the INSTALLATION window correctly. (page 27)
On-screen display does not appear.	OSD OFF button has been clicked.	Click the OSD ON button in the SCREEN CONTROL window (page 10).

## Remote Commander/SRX Controller

Symptom	Cause	Remedy
The SRX Controller does not start.	The projector and a computer for controlling the projector are not properly connected.	Check that the proper connection between the projector and a computer has been made (page 16).
The Remote Commander does not work.	The remote control detector has been removed.	Consult with qualified Sony personnel.
	The batteries are dead.	Replace with new batteries.

# Error Messages

The error messages are displayed in the STATUS MESSAGE window on the projector and the Error display window of the SRX Controller. If there are two or more messages, a displayed message changes each 5 seconds. Use the list below to check the meaning of the error, and consult with qualified Sony personnel. Be sure to inform them of the displayed messages and their numbers.

No.	Error messages	Meaning
1	INPUT-A POWER ALERT	Trouble with power of INPUT A board
2	INPUT-B POWER ALERT	Trouble with power of INPUT B board
3	INPUT-C POWER ALERT	Trouble with power of INPUT C board
4	INPUT-D POWER ALERT	Trouble with power of INPUT D board
5	PR-284_1 POWER ALERT	Trouble with power of PR-284 board at the top
6	PR-284_2 POWER ALERT	Trouble with power of PR-284 board on the second row
7	PR-284_3 POWER ALERT	Trouble with power of PR-284 board on the third row
8	PR-284_4 POWER ALERT	Trouble with power of PR-284 board on the fourth row
9	24V POWER SUPPLY ALERT	The projector has failed to supply 24V power.
10	16V POWER SUPPLY ALERT	The projector has failed to supply 16V power.
11	PR-284_1 DETACHED	The PR-284 board is not attached correctly on the top row.
12	SXRD PANEL TEMPERATURE ALERT	The temperature of the panels is too high.
13	LAMP_A FAN ALERT	Trouble with the fan for Lamp A, or the harness is disconnected or down.
14	LAMP_B FAN ALERT	Trouble with the fan for Lamp B, or the harness is disconnected or down.
15	LAMP_A POWER SUPPLY UNIT FAN ALERT	Trouble with the ballast fan for Lamp A power, or the harness is disconnected or down.
16	LAMP_B POWER SUPPLY UNIT FAN ALERT	Trouble with the ballast fan for Lamp B power, or the harness is disconnected or down.
17	PR-284 FAN ALERT	Trouble with the fan for PR-284 board, or the harness is disconnected or down.
18	OPTICAL UNIT TEMPERATURE ALERT	The temperature of the optical unit is too high, or the harness is disconnected or down.
19	LAMP_A TEMPERATURE ALERT	The temperature of Lamp A is too high, or the harness is disconnected or down.
20	LAMP_B TEMPERATURE ALERT	The temperature of Lamp B is too high, or the harness is disconnected or down.
21	LAMP_A HOUSE DETACHED	The projection lamp house of Lamp A is not installed correctly, or the harness is disconnected or down.
22	LAMP_B HOUSE DETACHED	The projection lamp house of Lamp B is not installed correctly, or the harness is disconnected or down.
23	REAR COVER DETACHED	The rear cover is open, or the harness is disconnected or down.
24	LAMP_A POWER SUPPLY UNIT ALERT	Trouble with the power (ballast) of Lamp A
25	LAMP_B POWER SUPPLY UNIT ALERT	Trouble with the power (ballast) of Lamp B
26	LAMP_A IGNITION FAILURE	Lamp A does not turn on.
27	LAMP_B IGNITION FAILURE	Lamp B does not turn on.
28	CPU ALERT	Trouble with the main CPU (IC301) on the SY-321. Serious trouble
29	MUTING OFF FAILURE DOUSER OPEN FAILURE	Trouble with opening/shutting of the shutter, or the harness is disconnected or down.
30	INPUT BOARD FAN ALERT	Trouble with the HIF fan next to the INPUT A/B/C/D boards, or the harness is disconnected or down.



No.	Error messages	Meaning
31	REAR FAN ALERT	Trouble with the huge fan at the rear, or the harness is disconnected or down.
32	LOW REAL TIME CLOCK BATTERY	The RTC battery (BT201) for the SY-321 board should be replaced.
33	FPGA CONFIG FAILURE	An internal line does not function properly.
34	IIC FAILURE	An internal line does not function properly.
35	LAMP A ALERT	The recommended time for replacement of Lamp A has elapsed.
36	LAMP B ALERT	The recommended time for replacement of Lamp B has elapsed.
37	LAMP A WARNING	80% of the recommended time for replacement of Lamp A has elapsed.
38	LAMP B WARNING	80% of the recommended time for replacement of Lamp B has elapsed.

# Specifications

## Optical characteristics

Projection system	SXRD (Silicon X-tal Reflective Display) 3 panel prism color integration system
SXRD	8,847,360 pixels (4098 × 2160 × 3)
Lens	Optional
Light output	SRX-R110: 10,000 ANSI <sup>1)</sup> lm ± 10% (factory preset value) SRX-R105: 5,000 ANSI <sup>1)</sup> lm ± 10% (factory preset value)
Lamp	SRX-R110: 2 kW Xenon lamp × 2 SRX-R105: 1 kW Xenon lamp × 2

1)ANSI lumen is a measuring method of American National Standard IT 7.228.

## Electrical characteristics

Acceptable signal	Component, XGA, SXGA, WXGA, HD (when the LKRI-001 analog input board is installed) HD-SDI (SMPTE Serial Digital Interface standard) (when the LKRI-002 HD- SDI (4:2:2) input board is installed)
-------------------	---

## Input/Output

INTER LOCK	Minijack Normal operation at short circuit Lamp power off at open circuit
RS232C	D-sub 9-pin (female) (For details, see “Pin assignment” on page 35.)
ETHERNET	10BASE-T/100BASE-TX

## Input signal

When the LKRI-001 is installed	Analog RGB/component: BNC type R/R-Y: 0.7 Vp-p ±2 dB positive, 75 ohms terminated G/G SYNC: 0.7 Vp-p ±2 dB positive, 75 ohms terminated G with sync/Y: 1 Vp-p ±2 dB sync negative, 75 ohms terminated B/B-Y: 0.7 Vp-p ±2 dB positive, 75 ohms terminated SYNC/HD: Composite sync: 0.6 – 8 Vp-p, high impedance, sync positive/ negative Horizontal sync: 0.6 – 8 Vp-p, high impedance, sync positive/negative VD: Vertical sync: 0.6 – 8 Vp-p, high impedance, sync positive/negative
--------------------------------	--

HDTV (YPbPr): BNC type Y: 1 Vp-p ± 2 dB positive, 75 ohms terminated Tri-level sync: ± 0.3 Vp-p Bi-level sync: 0.3 Vp-p Pb/Pr: 0.35 Vp-p ± 2 dB positive, 75 ohms terminated
HDTV (GBR): BNC type G with sync: 1 Vp-p ± 2 dB, 75 ohms terminated Tri-level sync: ± 0.3 Vp-p Bi-level sync: 0.3 Vp-p B/R (GBR): 0.7 Vp-p ± 2 dB positive, 75 ohms terminated

When the LKRI-002 is installed  
SMPTE format HD

## General

Dimensions	740 × 500 × 1320 mm (29 1/4 × 19 3/4 × 52 inches) (w/h/d)
Mass	Approx. 110 kg (242 lb 8 oz) (excluding the optional lens)
Power requirements	SRX-R110: 200 to 240 V AC, 50/60 Hz SRX-R105: 100 to 240 V AC, 50/60 Hz
Power consumption	SRX-R110: Max. approx. 5.4 kW (Standby mode: 40 W) SRX-R105: Max. approx. 3.0 kW (Standby mode: 40 W)
Current consumption	SRX-R110: 30 to 22 A SRX-R105: 30 to 12.5 A
Operating temperature	5°C to 35°C (41°F to 95°F) (About 20 minutes of aging is recommended to provide better quality picture.)
Performance guarantee temperature	10°C to 30°C (50°F to 86°F)
Operating humidity	35% to 85% (no condensation)
Storage temperature	–20°C to + 60°C (–4°F to +140°F)
Storage humidity	10% to 90%
Supplied accessories	Remote Commander RM-PJ4K (1) Size AA (R6) batteries (2) SRX Controller (CD-ROM) (1) Ethernet cable (cross cable manufactured by Sony: 1-830-803-11) (1) Operating Instructions (1) Installation Manual for Dealers (1) Operating Instructions (CD-ROM) (1) Quick Reference Guide (1)

Design and specifications are subject to change without notice.

## Optional accessories

Projection lamp house

LKRX-B110 (for SRX-R110)

LKRX-B105 (for SRX-R105)

Projection lamp

LKRX-110 (for SRX-R110)

LKRX-105 (for SRX-R105)

Analog input board

LKRI-001 (analog RGB/component/HD input with 5 BNC type)

HD-SDI (4:2:2) input board

LKRI-002 (HD-SDI input/output with 2 BNC type)

Projection lens

LKRL-Z115 (1.5 to 1.9-times zoom lens)

LKRL-Z120 (1.9 to 2.3-times zoom lens)

LKRL-Z125 (2.3 to 4.0-times zoom lens)

LKRL-Z140 (4.0 to 7.0-times zoom lens)

## Pin assignment

RS232C connector (D-sub 9-pin, female)

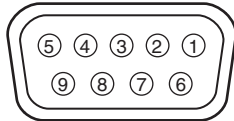

1	NC	
2	RD	Received Data
3	TD	Transmit Data
4	DTR*	Data Terminal Ready
5	GND	Ground
6	DSR*	Data Set Ready
7	RTS**	Request to Send
8	CTS**	Clear to send
9	NC	

\* Circuit between pins 4 and 6 is short-circuited in the projector.

\*\* Circuit between pins 7 and 8 is short-circuited in the projector.

## Preset Signals

Preset signal	fH (kHz)	fV (Hz)	Aspect ratio
VIDEO60	15.73	59.94	4:3
VIDEO50	15.63	50.00	4:3
HDTV	33.75	60.00	16:9
1024 × 768_VESA60	48.36	60.00	4:3
1024 × 768_VESA70	56.48	70.07	4:3
1024 × 768_VESA75	60.02	75.03	4:3
1024 × 768_VESA85	68.68	85.00	4:3
1280 × 960_VESA60	60.00	60.00	4:3
1280 × 1024_VESA60	63.97	60.01	5:4
1280 × 1024_VESA75	79.98	75.03	5:4
1280 × 1024_VESA85	91.15	85.02	5:4
1600 × 1200_VESA605	75.00	60.00	4:3
720/60P	45.00	60.00	16:9
720/50P	37.50	50.00	16:9
1080/48I (24PsF)	27.00	48.00	16:9
1080/50I	28.13	50.00	16:9

## Displayed image size in multiple screen mode

Unit: pixel

Screen mode Type of signal	Full screen		Dual screen		Quad screen	
	Horizontal size	Vertical size	Horizontal size	Vertical size	Horizontal size	Vertical size
VIDEO60	2880	2156	2003	1499	1440	1078
VIDEO50	2880	2146	2003	1504	1440	1073
XGA	2849	2137	2048	1536	1432	1074
SXGA	2560	2048	2048	1638	1280	1024
UXGA*	2864	2148	1600	1200	–	–
720p	3810	2143	2048	1152	1280	720
HD	3840	2160	1920	1080	1920	1080
4K	4096	2160	–	–	–	–

\* The UXGA signal does not support the quad-screen mode and no picture is displayed.

# Index

- A**
- Adjusters 13
  - Adjusting
    - focus 27
    - lens shift 27
    - picture 11, 26
    - zoom 27
- B**
- Battery
    - installation 11
    - notes 11
- C**
- Carrying handles 13
  - Color 26
  - Color Space 26
  - Color Temp 26
  - COLOR/FRAME window 26
  - Connection mode 17
  - Connections
    - component/video GBREquipment 18
    - computer 19
    - computer for controlling the projector 16
    - HD-SDI equipment 18
  - Control Function Menu window
    - Displaying 24
    - Location and function of controls 8
  - Cut off the picture 21, 23
- D**
- Dot Phase 27
- E**
- Error messages 32
  - ETHERNET connector 16
- F**
- Focus 21, 27
  - Frame Adjust 27
  - FUNCTION 1/2/3 24
- G**
- Gamma 26
- H**
- H Shift 27
  - H Size 27
- I**
- I/P Mode 25
  - Input Source 25
  - INSTALLATION 28
  - INSTALLATION window 27
  - Installing the projector 14
- L**
- Lamp Life 30
  - LAMP POWER 27
  - LAMP SELECT 28
  - LENS CONTROL 27
  - Location and Function of Controls
    - Control Function Menu window 8
    - Front/Top 7
    - Left Side/Rear 8
    - Remote Commander 10
- O**
- Optional accessories 35
- P**
- PICTURE CONTROL window 25
  - Precautions 5
  - Precautions on installation 12
  - PROGRESSIVE DISPLAY MODE 27
  - Projecting
    - Using the computer for controlling the projector 22
    - Using the Remote Commander 20
- R**
- Registering the settings 24
  - Remote Commander
    - Battery installation 11
    - Location and Function of Controls 10
  - Resetting the settings 24
  - RS-232C 16
- S**
- SCREEN CONTROL window 9
  - Screen mode 21, 22
  - Shift 21, 27
  - Signal Adjust 26
  - Signal Info 25
  - Signal Mode 25
  - Specifications 34
- SRX Controller**
- Browser Screen 17
  - installing 14
  - starting 17
- STATUS MESSAGE window 32
- Supplied accessories 34
- T**
- TEST PATTERN 28
  - Troubleshooting 31
- V**
- V Shift 27
- Z**
- Zoom 21, 27

<http://www.sony.net/>

Sony Corporation