

SERVICE MANUAL

Liquid Crystal Colour
Video Projector

Model No. PLC-200P
(Europe, Asia, Africa, M.E.)

Model No. PLC-200PB
(U.K.)

Model No. PLC-200PP
(Australia, New Zealand)

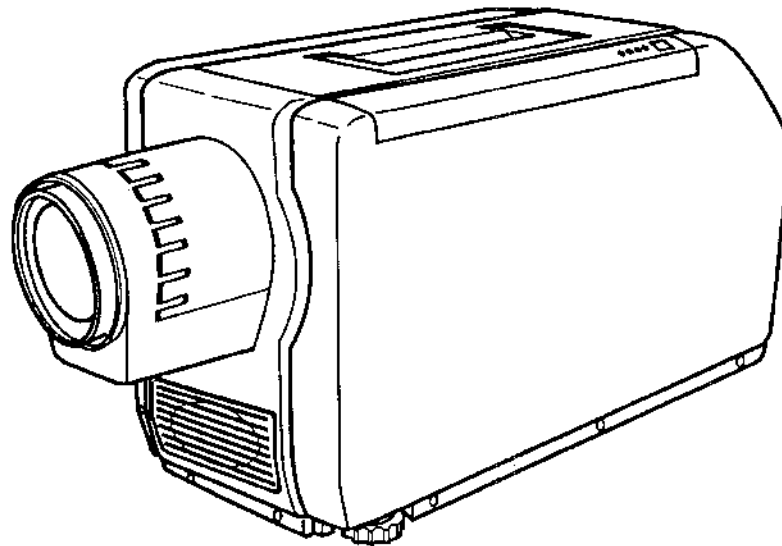

Contents	
Safety Instructions	2
Specifications	3
Fundamental Principles of Liquid Crystal Projector	4
System Control	5
Description of PLC-200P/PB/PP	6
Troubleshooting Chart	14
Lamp Replacement	18
Mechanical Disassemblies	19
LCD Panel Replacement	26
Optical Adjustments	28
Convergence Adjustments	31
Cleaning Methods	33
Service Adjustments	35
Chassis Electrical Parts List	41
Cabinet Parts List	55
Voltage & Waveforms	61
Block Diagrams	71
Schematic Diagrams	72
Component and Testpoint Locations	88

ORIGINAL VERSION

Service PLC-200P-00
Ref. No. PLC-200PB-00
PLC-200PP-00

PRODUCT CODE

E5SA(PLC-200P); 1113 143 00

E5SB(PLC-200PB); 1113 143 01

E5SC(PLC-200PP); 1113 143 02

REFERENCE NO. SM520033

SAFETY INSTRUCTIONS

SAFETY PRECAUTIONS

WARNING: The chassis of this projector is isolated (COLD) from AC line by using the converter transformer. Primary side of the converter transformer and lamp power supply unit circuit is connected to the AC line and it is hot, which hot circuit is identified with the line in the schematic diagram. For continued product safety and protection of personnel injury, servicing should be made with qualified personnel.

The following precautions must be observed:

1. An isolation transformer should be connected in the power line between the receiver and the AC line before any service is performed on the projector.
2. Comply with all caution and safety - related notes provided on the cabinet back, cabinet bottom, inside the cabinet or on the chassis.
3. When replacing a chassis in the cabinet, always be certain that all the protective devices are installed properly, such as control knobs, adjustment covers or shields and barriers.

DO NOT OPERATE THIS PROJECTOR WITHOUT THE PROTECTIVE SHIELD IN POSITION AND PROPERLY SECURED.

4. Before replacing the cabinet cover, thoroughly inspect the inside of the cabinet to see that no stray parts or tools have been left inside.

Before returning any projector to the customer, the service personnel must perform the following safety checks and be sure that it is completely safe to operate without danger of electrical shock.

PRODUCT SAFETY NOTICE

Product safety should be considered when a component replacement is made in any area of the projector. Components indicated by a mark (Δ) in the parts list and the schematic diagram designate components in which safety can be of special significance. It is, therefore, particularly recommended that the replacement of these parts must be made by exactly the same parts.

" SERVICE PERSONNEL ---- WARNING " and the following or the equivalent : " Eye Damage May Result From Directly Viewing The Light Produced By The Lamp Used In This Equipment.

Always Turn Off Lamp Before Opening Cover. Ultraviolet Radiation Eye Protection Required During This Servicing. "

Never turn the power on without the lamp to avoid electric - shock or damage of the devices since the stabilizer generates high voltages(10kV - 15kV) at its start.

Since the lamp is very high temperature during units operation replacement of the lamp should be done at least one hour after the power has been turned off, to allow the lamp cool - off.

SPECIFICATIONS

Projector Type	Portable LC colour video projector
Dimensions (H x W x D)	253 mm x 268 mm x 572 mm
Net Weight	12.0 kg (26.4 lbs)
LCD Panel System	3.1" TFT Active Matrix type (Thin Film Transistor) x 3
Number of Pixels	331,350 (110,450 x 3)
Colour System	4 colour system (PAL, SECAM, NTSC4.43 and NTSC)
Projection Image Size (Diagonal)	63 cm to 762 cm (25 to 300 inch) Adjustable
Contrast Ratio	100 : 1
Horizontal Resolution	450 TV lines
Projection Lens	f4.2 ~ 4.5 lens with 135 mm ~ 270 mm Motor-drive zoom and focus
Lens Aperture	67 mm
Throw Distance	2.3 m ~ 13.4 m
Projection Lamp	Metal Halide, 160 watt
Projection Mirror	Dichroic mirror system
AV Input Jacks	PHONO Type x 1 (Video, Audio R and L), DIN 4 pin (S-Video) x 1 and 21 pin (SCART) x 1
Audio Monitor Output Jacks	PHONO Type x 1 (R and L)
Built-in Speaker	3W RMS
Image Elevation Adjustment	Up 5°, Down 5°
Voltage	220 ~ 240V AC, 50/60Hz
Power Consumption	240 Watts
Operating Temperature	5°C ~ 35°C
Storage Temperature	-10°C ~ 60°C
Remote Control Battery	AA,UM3 or R06 type x 3
Standard Accessories	Remote Control Unit, R/C Cable (1.5m), AC Cord Owner's Instruction Manual, Protective Dust Cover

FUNDAMENTAL PRINCIPLES OF LIQUID CRYSTAL PROJECTOR

The white light from the light source is separated into red (R), green (G), and blue (B) light components by dichroic mirror, and each of these is projected onto three liquid crystal panels.

The three liquid crystal panels are driven by the primary color signals R/G/B, and R/G/B images are reproduced by the shutter operation of these liquid crystal panels. These reflections are condensed by lens and projected onto the screen.

The structure of the liquid crystal projector is shown in the diagram. The ultraviolet and infrared rays are cut out from the light beams given off from the metal halide lamp, which is the light source, by UV cut filter and cold filter at the beginning. This is to eliminate unnecessary light components in the projected images, and serves to protect the liquid crystal panel from the light and heat of the lamp.

The light beam, now made up only of visible light components, next undergoes spectral diffraction of the red light by the dichroic mirror used for the selecting out of red. The spectrally diffracted red light is reflected by the aluminum full reflection mirror, is projected onto panel unit R, and here the red component image is formed.

The light beam, with the red light having been separated out, next undergoes spectral diffraction of the green light by the dichroic mirror used for the selecting out of green. The spectrally diffracted green light is projected onto panel unit G, and here the green component image is formed.

The images formed on panel units R and G are mixed together by the dichroic mirror used for green mixing.

After spectral diffraction of the red and green light, the light beam (blue light) is projected onto panel unit B, and here the blue component image is formed.

The image formed on panel unit B, after being reflected by the aluminum full reflection mirror, is mixed with the red and green fused image by the dichroic mirror used for blue mixing. The mixed image is thereupon projected onto the screen through a lens.

Liquid crystal projector conceptual diagram

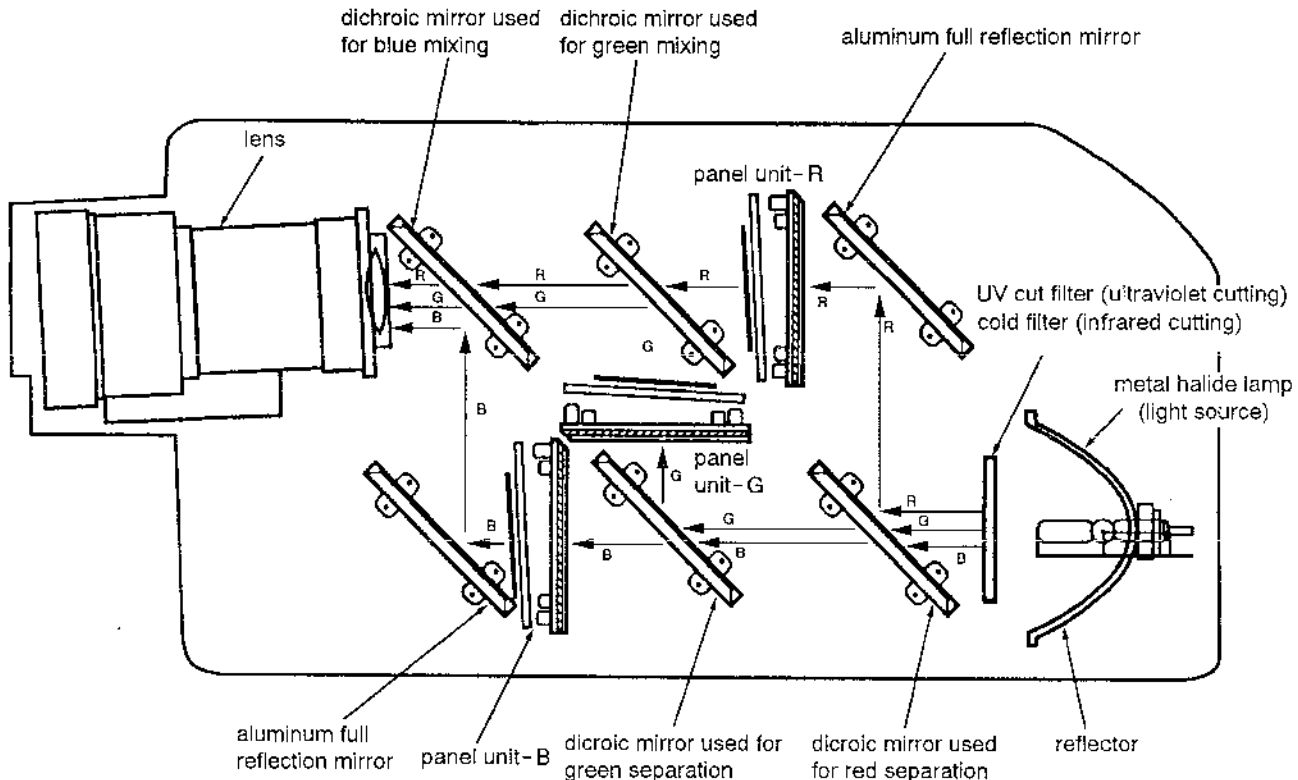

SYSTEM CONTROL

All systems are controlled by IC801 (CPU).

Main functions:

1. Power ON/OFF.
2. Input selection.
3. Digital control.
4. On screen display.
5. Volume control.
6. Lamp monitor (Standby).
7. Temperature monitor (Temp. Warning).
8. Lamp replacement monitor (Lamp replace).
9. Zoom and Focus motor control.

1. Power ON/OFF.

CPU controls the power relay by a signal from the unit or the remote control.

2. Input selection.

Input selection will be switched from AV1 → AV2 → RGB → AV1 by the V.MODE button on the unit or remote control. During this operation "V.MODE" will be shown on the right corner for 5 seconds. When you turn on the power switch, the lamp is not stable yet and the indication will be shown for 30 seconds.

3. Digital control.

Digital control will be switched from COLOUR → TINT → CONTRAST → BRIGHTNESS → SHARPNESS → SOUND by pressing the FUNCTION button. After these selections, level can be adjusted by LEVEL button. Indication on the screen will be off after 8 seconds. When you press "NORMALIZATION" button, "NORMALIZATION" will be shown on the screen and all digital controls will be switched back to the factory setting. "NORMALIZATION" indication will be shown for 5 seconds.

4. On screen display.

All functions will be shown on the screen. Signal will be output from CPU and combined at signal circuit.

5. Volume control.

Volume will be adjusted by the buttons on the unit and remote. The indication will be shown for 5 seconds. The sound will be muted by the mute button and the indication will be changed to red color for 5 seconds.

6. Lamp monitor.

This unit uses a metal-halide arc lamp. This lamp is operated at high voltage. 10 kV~15 kV will be used at striking and 80 V after lamp is on. This lamp generates heat and needs cooling. After turning off the lamp, the cooling fan continues to run for one minute to cool down the lamp. This is required to reduce the gas pressure inside the lamp. During this period, the lamp can not be turned on. The green LED will not be on for one minute after turning off the lamp. After one minute the indicator will be on and the lamp is ready to start again.

7. Temperature monitor.

When the temperature rises due to an inoperative fan or poor ventilation, the power will be automatically turn off and the red LED Indicator will light. The temperature is monitored by a bi-metal temp. sensor.

8. Lamp replacement monitor.

The lamp has a life. The orange LED indicator will inform you of the **recommended replacing time**. The indicator will be lit after 1000 hours of use.

Note: Projectors with the following serial numbers are set to 2000 hours. The serial No. is shown on the rating plate.

MODEL NO.	SERIAL NO.
PLC-200P:	G2601001 ~ 1010, G2701011 ~ 1340, G2801341 ~ 1650
PLC-200PB:	G2801001 ~ 1050
PLC-200PP:	G2701001 ~ 1060

Accumulated time will be stored in NON-VOLA memory (IC803) by CPU (IC801), and this information is not erased after the power cord is unplugged. After replacing the lamp, RESET switch should be set. This switch is only activated when Power is on. "RESET" indication will be shown on the screen. Do not press this RESET switch other than replacing the lamp. In the case of replacing control unit for repairing NON-VOLA memory IC (IC803) should be used continually.

9. Zoom and Focus motor control.

Two DC motors are attached to the lens for zoom, focus adjustment.

When adjusting zoom, "ZOOM" will be shown on the screen and it will be 5 seconds after releasing the switch. When adjusting focus, "FOCUS" will be shown on the screen and it will be off 5 seconds after releasing the switch. For motor protection purpose the motor will stop after pressing the switch for 10 seconds.

DESCRIPTION

FRONT

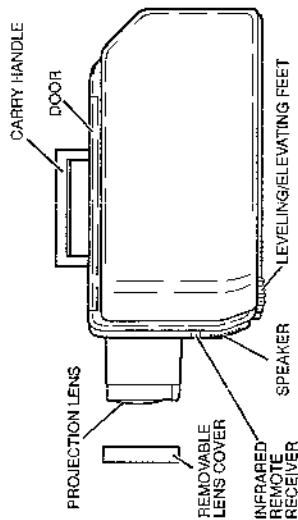

REAR

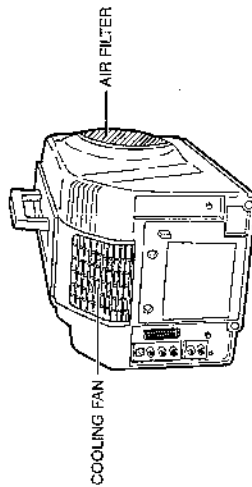

Connect the AC power supply cord (supplied) to the projector.

MOVING THE PROJECTOR

Use the carry handle when moving the projector.

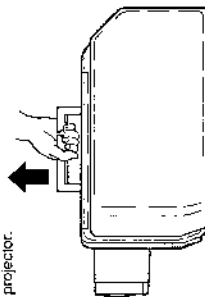

Replace the lens cover when moving the projector to prevent damage to the lens.

TROUBLE SHOOTING GUIDE

Please perform these simple checks before calling for service.

SYMPTOMS	PROCEDURES
No power	<ul style="list-style-type: none"> Plug the projector into an AC outlet. Press the MAINS ON/OFF button to ON. Press the POWER (LAMP) ON/OFF button to ON. Check the READY INDICATOR light ON. One minute has not passed since LCD projector turned OFF. <p>NOTE: After pressing the POWER (LAMP) ON/OFF button to OFF the projector, the projector functions as follows.</p> <ol style="list-style-type: none"> The POWER and READY indicator will turn off. The cooling fan will operate for 1 minute after the projector is turned off. (During this "cooling down" period, the projector can not be turned on.) After 1 minute, the READY indicator will light green again and the projector may be turned on by pressing the POWER (LAMP) ON/OFF button on the projector or on the remote control unit.
No sound from built-in speaker	<ul style="list-style-type: none"> Press the VOLUME (▲) and (▼) to (▲). Press the INT. SP ON/OFF button to ON. Check audio cable connection from audio input source.
Picture is reversed	<ul style="list-style-type: none"> Press the REVERSE PICTURE SCANNING button.
Picture blurred or colour faded	<ul style="list-style-type: none"> Check the project on distance (2.3m-13.4m). Adjust the FOCUS control. <p>NOTE: Moving the projector from a cool temperature location to a warm temperature location may result moisture condensation on the lens. In such an event, leave the projector OFF and wait until condensation disappears.</p>

OPERATION OF CONTROLS

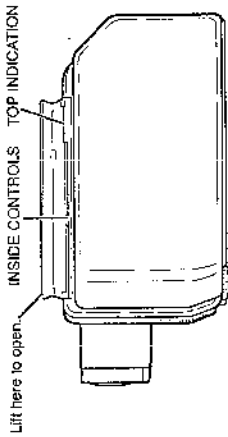

INSIDE CONTROLS

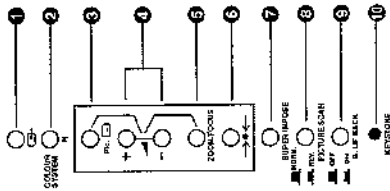

- 1 VIDEO MODE SELECT BUTTON
Press to select video source, (Video Input-1, Video Input-2, or RGB INPUT)
- 2 COLOUR SYSTEM SELECT BUTTON
Press to select colour system. (AUTO → PAL → SECAM → NTSC4.43 → NTSC)
- 3 FUNCTION SELECT BUTTON
Used to select on-screen adjustant displays for colour, tint, brightness, contrast, sharpness and sound. Press repeatedly to cycle.
- 4 LEVEL CONTROL BUTTONS
Used to adjust volume, zoom, focus, colour, tint, brightness, contrast, sharpness and keystone by pressing + or - button.
- 5 ZOOM/FOCUS BUTTON
Used to select power zoom lens or focus system.
- 6 NORMALIZATION BUTTON
Used to reset to normal factory set picture and sound adjustment.
- 7 SUPERIMPOSE BUTTON
Press this button to produce white characters and lines on a blue background.
- 8 REVERSE PICTURE SCANNING BUTTON
Automatically reverses the projected screen image.
- 9 BLUE BACK BUTTON
Used to project the blue image without video noise on the screen when the video source is unplugged or turned off.
- 10 KEYSTONE BUTTON
Used to select the keystone correction mode.
- 11 LAMP REPLACEMENT INDICATOR
Lights orange when projection lamp is nearing end of service life.
- 12 TEMPERATURE WARNING INDICATOR
Lights red when internal projector temperature is too high.
- 13 READY INDICATOR
Lights green when projector is ready to be turned on.
- 14 POWER INDICATOR
Lights dim when the projector is on.
- 15 POWER (LAMP) ON/OFF BUTTON
Press to turn projection lamp on or off.

TOP INDICATION

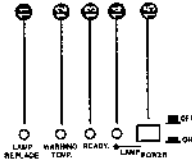

BACK OF THE PROJECTOR

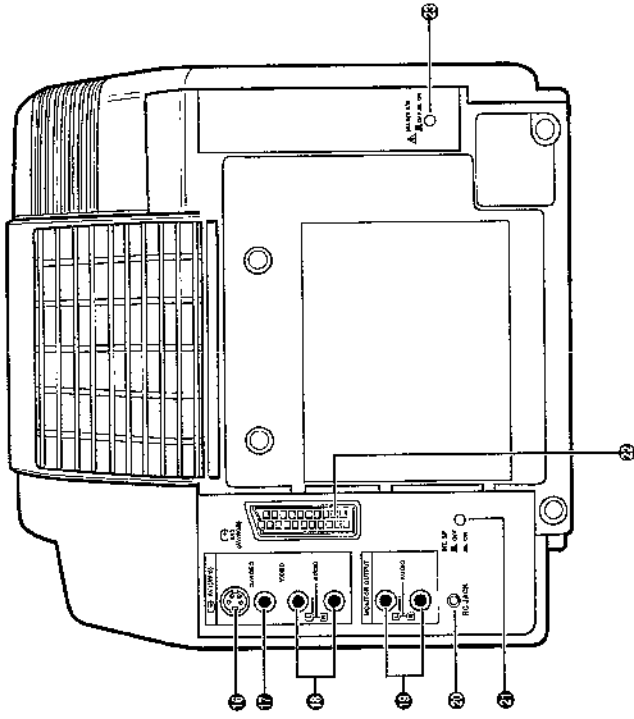

- 1 S-VIDEO INPUT JACK
Used to connect a S-VHS video source to the projector.
- 2 VIDEO INPUT-1 JACK
Used to connect a video source to the projector.
- 3 AUDIO INPUT-1 JACKS
Used to connect an audio input to the projector.
- 4 AUDIO MONITOR OUTPUT JACKS
Permits audio connection to a monitor.
- 5 WIRED REMOTE JACK
When using the wired remote control, connect the remote cable to this jack.
- 6 INT. SP. ON/OFF BUTTON
Turns the built-in speaker on or off.
- 7 21-PIN TERMINAL
Used to connect a video source with a 21-pin terminal to the projector.
- 8 MAINS ON/OFF BUTTON
Press to turn the projector on.

REMOTE CONTROL OPERATION

INFRARED/WIRED REMOTE CONTROL

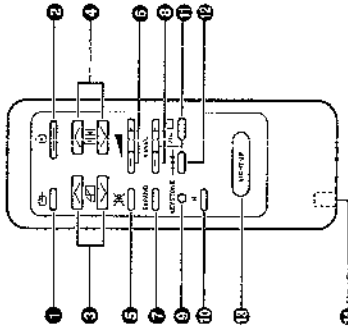

- 1 VIDEO MODE SELECT BUTTON**
Press to select video source. (Video Input-1, Video Input-2 or RGB Input)
- 2 POWER (LAMP) ON/OFF BUTTON**
Press to turn projection lamp on or off.
- 3 ZOOM BUTTONS**
Used to operate power zoom lens.
- 4 FOCUS BUTTONS**
Used to operate power focus system.
- 5 SOUND MUTE BUTTON**
Used to mute sound.
- 6 VOLUME BUTTONS**
Used to adjust volume.
- 7 EXPAND BUTTON**
Press to expand the center portion of the image twice. This function is cancelled when the EXPAND button is pressed again or any other function button is pressed.
- 8 LEVEL CONTROL BUTTONS**
Used to adjust zoom, focus, colour, tint, brightness, contrast, sharpness and keystone by pressing + or - button.
- 9 KEYSTONE BUTTON**
Used to select the keystone position.
- 10 COLOUR SYSTEM SELECT BUTTON**
Press to select colour system. (AUTO → PAL → SECAM → NTSC4.43 → NTSC)
- 11 FUNCTION SELECT BUTTON**
Used to select on-screen adjustment displays for colour, tint, brightness, contrast and sharpness. Press repeatedly to cycle.
- 12 NORMALIZATION BUTTON**
Used to reset to normal factory set picture and sound adjustment.
- 13 LIGHT UP BUTTON**
Press to light the illumination for function buttons on the remote control unit for 5 seconds, and press any other function button during the lighting to light for another 5 seconds.
- 14 WIRED REMOTE JACK**
When using the wired remote control, connect the remote cable to this jack.

REMOTE CONTROL BATTERY INSTALLATION

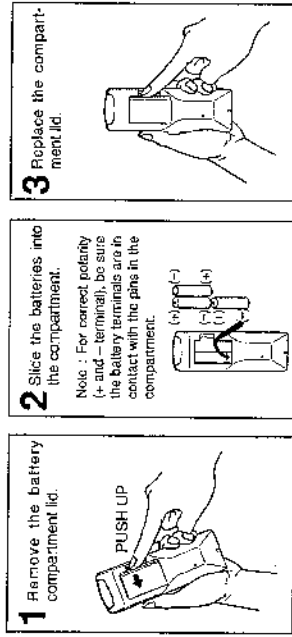

1 Remove the battery compartment lid.

2 Slice the batteries into the compartment.

Note : For correct polarity (+ and - terminal), be sure the battery terminals are in contact with the pins in the compartment.

3 Replace the compartment lid.

The remote control unit can be used as wireless or wired remote control.

USING THE REMOTE CONTROL UNIT (wireless)

Point the remote control toward the front of the projector (Receiver window) whenever pressing the buttons. Maximum operating range for the remote control is about 5m and 150° from the front of the projector.

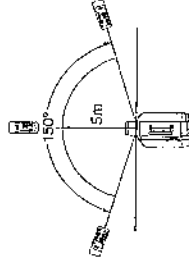

USING THE REMOTE CONTROL UNIT (wired)

Connect a remote control cable to RC jacks located on the remote control unit and the back of the projector.

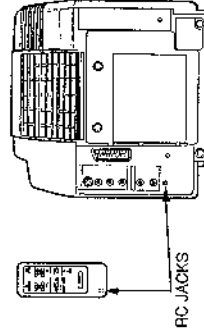

To insure safe operation, please observe the following precautions:

- Use (3) AA, UM3 or R06 type batteries.
- Change three batteries at the same time.
- Do not use a new battery with a used battery.
- Avoid contact with water.
- Do not drop the remote control unit.

SETTING-UP THE PROJECTOR

- This projector is basically designed to project on a flat projection surface. If the projector is not placed at 90° angle to the screen, the projected image will have a keystone distortion.
- This projector can be focused from 2.3m ~ 13.4m.
- Use the illustration below as an example when positioning the projector to the screen.

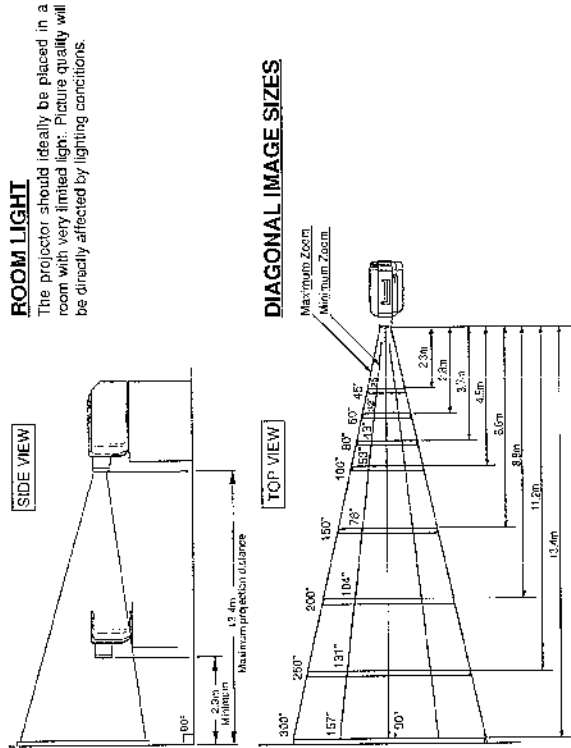

LEVELING AND ELEVATING ADJUSTMENTS

Picture adjustments can be made with the two leveling/elevating feet. Adjustments of 5° up are possible by rotating the feet on the bottom of the projector. Adjustments of 5° down are possible by raising up the stand.

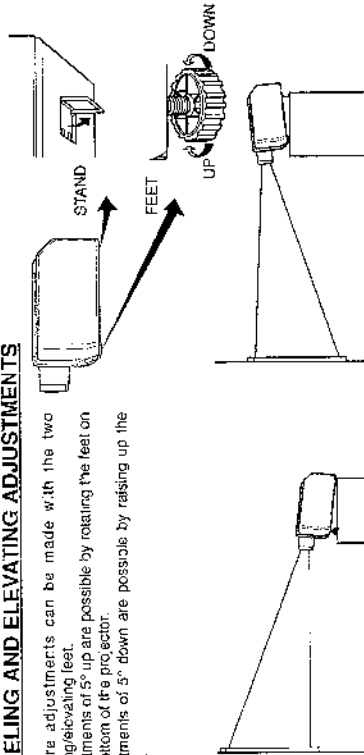

USING THE PROJECTOR

TO TURN ON THE PROJECTOR

Connect the projector to a video source (VCR, Video Camera, Video Disc Player, etc.) using the appropriate terminals on the rear of the projector.

Connect the projector's AC power cord into a wall outlet, and press the MAINS ON/OFF button (locate on projector). The READY indicator will light GREEN.

Press the POWER (LAMP) ON/OFF button on the projector to ON. The POWER indicator will light dim, and the cooling fan will operate. The wait display (A MOMENT/AIN MOMENT) and numeral (30) appears on the screen and the count-down starts (30, 29, 28, ... 1). The signal from the video source appears after 30 seconds. Now the remote control unit can be activated, and all functions may be used.

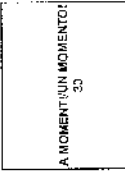

CAUTION:

- THIS PROJECTOR USE A METAL-HALIDE ARC LAMP. IF YOU TURN ON THE LAMP, DO NOT TURN IT OFF FOR AT LEAST 5 MINUTES, SO AS NOT TO SHORTEN ITS LIFE.
- DO NOT UNPLUG THE PROJECTOR AND PRESS MAINS ON/OFF BUTTON (LOCATE ON PROJECTOR) TO OFF UNTIL THE COOLING FAN HAS STOPPED OPERATING.

NOTE 1: After you turn off the projector use the POWER (LAMP) ON/OFF button on the projector or on the remote control unit you must wait one minute before you can turn the projector on again.

NOTE 2: TEMPERATURE WARNING INDICATOR flashes red, the projector will automatically turn off. Wait at least 5 minutes before turning the projector on.

If the TEMPERATURE WARNING INDICATOR continues to flash, follow the procedures below:

- (1). Press POWER (LAMP) ON/OFF button to OFF.
- (2). Check the air filter for dust accumulation.
- (3). Remove dust with vacuum cleaner.
- (4). Press POWER (LAMP) ON/OFF button to ON.

If the TEMPERATURE WARNING INDICATOR still continues to flash, call your authorized distributor for service.

TO TURN OFF THE PROJECTOR (with the remote control unit)

Press the POWER (LAMP) ON/OFF button on the remote control unit to OFF. The POWER indicator will light bright and READY indicator will turn off. The cooling fan will operate for 1 minute after the projector is turned off. (During this "cooling down" period, the projector can not be turned on.)

After 1 minute, the READY indicator will light green again and the projector may be turned on by pressing the POWER (LAMP) ON/OFF button on the remote control unit.

NOTE: Remote control unit can be activated only when POWER (LAMP) ON/OFF button on the projector is pressed to ON.

TO TURN OFF THE PROJECTOR (without the remote control unit)

Press the POWER (LAMP) ON/OFF button on the projector to OFF. The POWER and READY indicator will turn off. The cooling fan will operate for 1 minute after the projector is turned off. (During this "cooling down" period, the projector can not be turned on.)

After 1 minute, the READY indicator will light green again and the projector may be turned on by pressing the POWER (LAMP) ON/OFF button on the projector.

NOTE: If the projector is turned off by the remote control unit, it can be turned back on without the remote by pressing the POWER (LAMP) ON/OFF button on the projector twice.

ADJUST THE PROJECTOR

VIDEO MODE SELECT

Press the VIDEO MODE select button (located on projector or remote control unit) to select Video Input-1, Video Input-2 or "RGB" input. The "AV1", "AV2" or "RGB" display will appear on the screen.

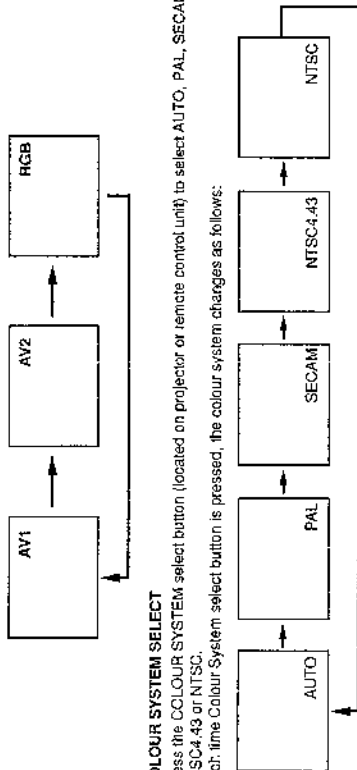

COLOUR SYSTEM SELECT

Press the COLOUR SYSTEM select button (located on projector or remote control unit) to select AUTO, PAL, SECAM, NTSC-4.43 or NTSC.

Each time Colour System select button is pressed, the colour system changes as follows:

When the colour system is set to "AUTO" position, this projector can receive colour programs from one of the 4 systems (PAL, SECAM, NTSC-4.43 or NTSC), automatically. If the picture quality is poor, make sure the proper colour system is selected to match the video source.

VOLUME ADJUSTMENT

Press INT. SP ON/OFF button to ON(IN) position when the INTERNAL SPEAKER is used.
 Press LEVEL buttons on the projector, or VOLUME buttons on the remote control unit to adjust the volume. The screen display will appear.
 Pressing (+) will increase volume and the green indicator will increase to the right on the screen.
 Pressing (-) will decrease volume and the green indicator will decrease to the left on the screen.
 Press INT. SP ON/OFF button to OFF (OUT) position, will disengage the internal speaker or the projector.

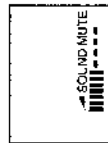
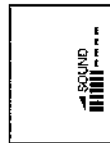

SOUND MUTE ADJUSTMENT

Pressing SOUND MUTE button on the remote control unit will mute audio (Sound Mute display will appear). Press SOUND MUTE button again to restore audio to its previous level.

ZOOM ADJUSTMENT (Without remote control unit)

Press ZOOM/FOCUS button until zoom display will appear on the screen, and press LEVEL (+) or (-) to obtain your desired picture size. (The zoom display will appear for 5 seconds.) For the larger size, press (+) and for the smaller size, press (-).

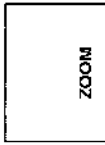

ZOOM ADJUSTMENT (With remote control unit)

Press ZOOM (Δ) or (∇) to obtain your desired picture size. (The zoom display will appear for 5 seconds.) For the larger size, press (Δ) and for the smaller size, press (∇).

FOCUS ADJUSTMENT (Without remote control unit)

Press ZOOM/FOCUS button until focus display will appear on the screen, and press LEVEL (+) or (-) for sharper, crisper picture. (The focus display will appear for 5 seconds.)

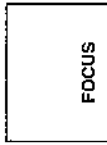

FOCUS ADJUSTMENT (With remote control unit)

Press FOCUS (Δ) or (∇) for sharper, crisper picture. (The focus display will appear for 5 seconds.)

COLOUR AND PICTURE ADJUSTMENT

The normal picture level is factory preset on the projector and can be obtained anytime by pressing the NORMALIZATION button on the projector, or on the remote control unit. The picture level adjustment can be made by using the FUNCTION and LEVEL buttons on the projector, or on the remote control unit.

OTHER FEATURES

SUPERIMPOSE

Pressing SUPERIMPOSE button on the projector produces white character and lines on a blue background.

BLUE BACK

Pressing BLUE BACK button on the projector to project the blue image without video notes on the screen when the video source is unplugged or turned off.

EXPAND

Press EXPAND button on the remote control unit to expand the center portion of the image twice. This function is cancelled when the EXPAND button is pressed again or any other function button is pressed.

REVERSE PICTURE SCANNING

The versatile left/right picture reverse capability lets you project onto the screen from in front or behind.

- Press the REVERSE PICTURE SCANNING button on the projector, if required.



KEYSTONE CORRECTION

When the projector is used at upper or lower position, keystone distortions appear at the bottom or top of the screen. The keystone can be corrected as follows:

- LOW MOUNT PROJECTION

If the projector is mounted low, the keystone will appear at the top of the screen. Press Keystone button on the projector, or remote control unit using the tip of a ball-point pen until the bar appears on the top of the screen. Press the level (-) button until the keystone is corrected.

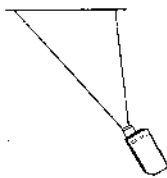

TOP KEYSTONE CORRECTION DISPLAY

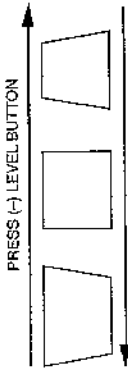

- HIGH MOUNT PROJECTION

If the projector is mounted high, the keystone will appear at the bottom of the screen. Press Keystone button on the projector, or remote control unit using the tip of a ball-point pen until the bar appears on the bottom of the screen. Press the level (+) button until the keystone is corrected.



BOTTOM KEYSTONE CORRECTION DISPLAY

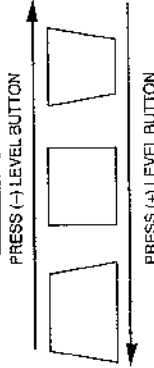

NOTE: The projector is equipped with a built-in memory feature that eliminates the need to readjust the keystone each time the projector is turned off and the AC power cord is disconnected.

PICTURE AND SOUND ADJUSTMENTS

INSIDE CONTROLS OF THE PROJECTOR

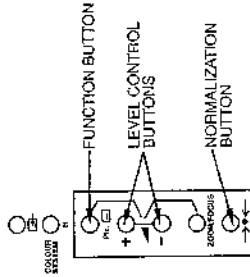

REMOTE CONTROL UNIT

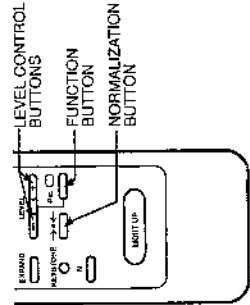

Picture and sound adjustments have been preset at the factory to our quality standards. However, with the FUNCTION and LEVEL buttons on the projector or on the remote control unit you can make picture and sound adjustments you personally prefer.

1. Select the picture and sound adjustments function by pressing FUNCTION button.

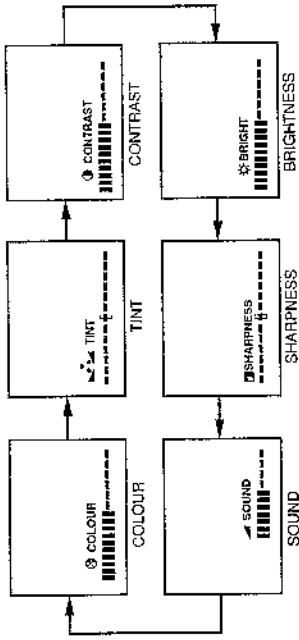

2. Each time FUNCTION button is pressed, the control function changer as follows:

NOTE: 1. "SOUND" will be appears, only when FUNCTION button above the projector is pressed.

2. "TINT" will be skipped during in the PAL and SECAM mode.

3. Adjust the colour intensity, tint, contrast, brightness, sharpness or sound by pressing LEVEL (+ and -) buttons.

	LEVEL	
COLOUR	DECREASES ← → INCREASES	
TINT	MORE PURPLE ← → MORE GREEN	
CONTRAST	SOFTER ← → SHARPER	
BRIGHTNESS	DARKER ← → BRIGHTER	
SHARPNESS	SOFTER ← → SHARPER	
SOUND	DECREASES ← → INCREASES	

• Press the LEVEL CONTROL buttons to make adjustments. Refer to the control chart below.

3. The ON-SCREEN display will disappear automatically in 8 seconds.

NOTE: The projector is equipped with a built-in memory feature that can maintain the picture and sound level adjustment to set on AV1 and AV2/RGB respectively even if the projector is turned off and AC power cord is disconnected. If NORMALIZATION button is pressed, the projector will return to factory preset level.

CONNECTING THE PROJECTOR

Your projector is equipped with various audio/video inputs and outputs including S-VHS video input and 21-pin terminals.

CONNECTING TO THE AV1 INPUT JACKS

Connect to the video and audio outputs of a VCR, video disc player, video camera, satellite TV tuner or other AV equipment.

- If the audio signal from the AV equipment is stereo, be sure to connect the right and left channels to the respective right and left audio input jacks.
- If the external audio signal is monaural, connect it to the left jack.

S-VHS FORMAT VCR CONNECTION

The AV1 input includes an extra video input jack marked S-VIDEO to allow connection to an S-VHS format VCR that has separate YC video signals. The S-VIDEO jack has priority over the VIDEO jack.

CONNECTING TO THE AV2 21-PIN TERMINAL

VCR, Video disc player or other AV equipment can be connected to the 21-pin terminal on the rear of the projector. When the 21-pin terminal is used for connection of AV equipment, note the following points.

- When using the equipment with the output function signal into PIN No. 8 of 21-pin terminal below, the VIDEO MODE is automatically set to "AV2" and VIDEO MODE selection is not required. And when using equipment without the output function signal, press VIDEO MODE select button on the projector or remote control to select "AV2" mode.

- When using the equipment with RGB output signal and without the control signals for PIN No. 8 and 16 of 21-pin terminal below, press VIDEO MODE select button to select "RGB" mode, and when using equipment with both RGB output signal and the control signals, the VIDEO MODE is automatically set to "AV2" mode and VIDEO MODE selection is not required.

CONNECTING TO THE AUDIO MONITOR OUTPUT JACK

These jacks will contain the audio information of the selected program source being viewed on the screen. If you have selected program source AV1 the audio signals connected to the AV1 jacks will be available at the audio monitor output jacks.

- If the audio input of the audio equipment is stereo, be sure to connect the right and left channels to the respective right and left jacks.
- If the audio input of the audio equipment is monaural, connect it to the left jack.

Specification of 21-pin terminal

Pin No.	Signal	Pin No.	Signal
1.	Audio output (right channel)	11.	Green (G) input
2.	Audio output (right channel)	12.	Not used
3.	Audio output (right channel)	13.	Earth (red)
4.	Earth (audio)	14.	Earth
5.	Earth (blue)	15.	Red (R) input
6.	Audio input (left channel)	16.	Fast blanking
7.	Blue (B) input	17.	Earth (video)
8.	Function switching	18.	Earth
9.	Earth (green)	19.	Video sync. input
10.	Not used	20.	Vidac sync. input
		21.	Earth

21-PIN TERMINAL

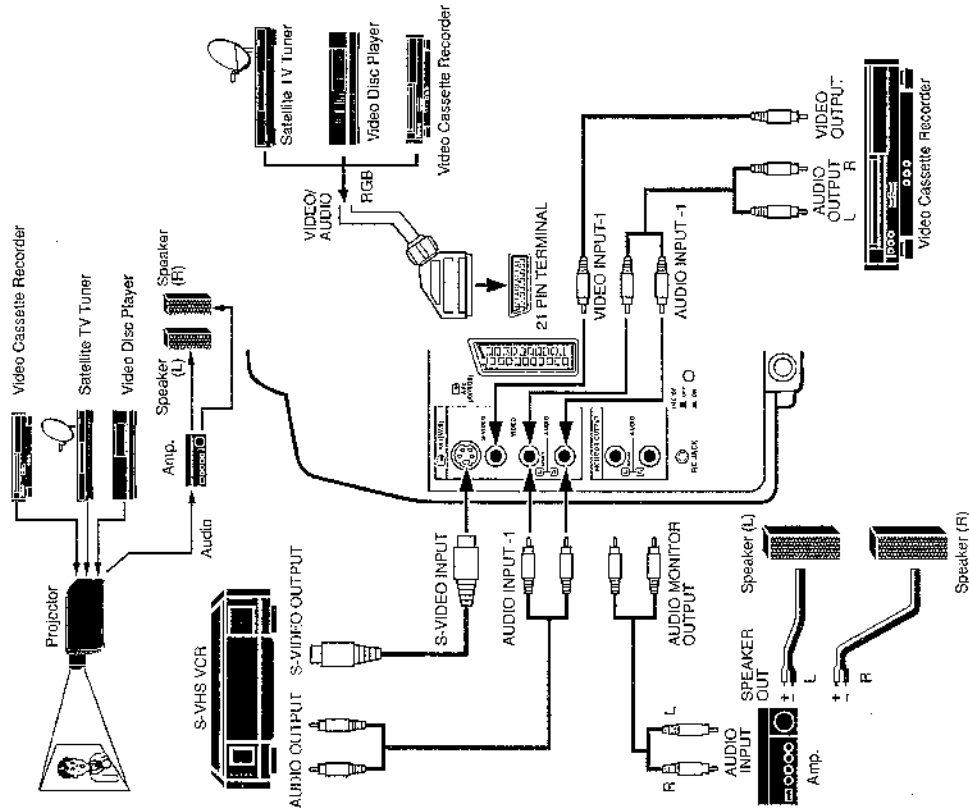

AIR FILTER CARE AND CLEANING

The removable air filter prevents dust from accumulating on the surface of the projection lens and projection mirror. Should the air filter become clogged with dust particles, it will reduce the cooling fan's effectiveness and may result in internal heat built up and reduced the life of the projection lamp.

To clean the air filter, follow the cleaning procedures below:

1. Turn the POWER (LAMP) ON/OFF button OFF.
2. Remove the air filter cover from the side of the projector.
3. Remove the air filter and sponge from the filter cover.
4. Clean the air filter and sponge with a vacuum cleaner.
5. Replace the air filter and sponges. Make sure that air filter cover is fully inserted.

▲ Do not clean with water. Doing so may damage the air filter.
Do not operate the projector with air filter removed.

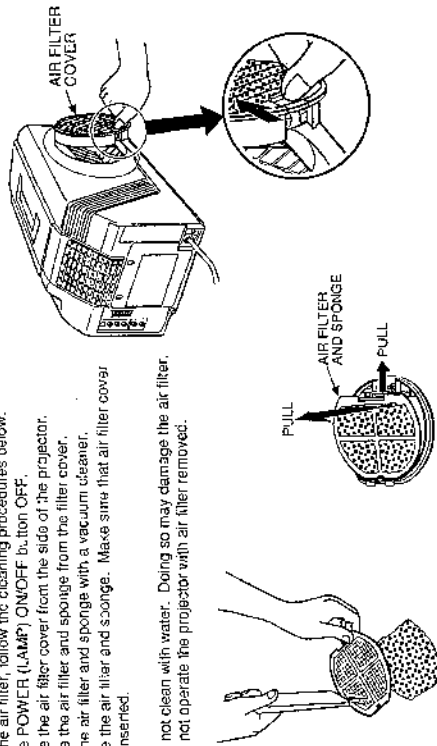

12 LAMP REPLACEMENT & TEMPERATURE WARNING INDICATORS

LAMP REPLACEMENT INDICATOR

When the lamp nears the end of its service life, the picture quality and colour quality will deteriorate and the lamp replacement indicator will light orange.

▲ DO NOT ATTEMPT TO REMOVE OR CHANGE THE PROJECTION LAMP. THE LAMP CAN ONLY BE CHANGED BY QUALIFIED SERVICE PERSONNEL.

TEMPERATURE WARNING INDICATOR

The TEMPERATURE WARNING INDICATOR lights red when the internal temperature of the projector exceeds the normal temperature.

Possible causes for the temperature warning may be:

1. Ventilation slots at the rear or bottom of the projector are blocked. In such an event, reposition the projector so that ventilation slots are not obstructed.
 2. Air filter is clogged with dust particles. Remove dust from the air filter by following instructions in the Air Filter Care and Cleaning section above.
- If temperature warning indicator remains on after performing the checks listed above, cooling fan/internal circuits may be malfunctioning. Request service from an authorized distributor or service station.

TROUBLESHOOTING CHART

The below chart is troubleshooting guide on a circuit characteristic of this projector and describes the general standard for discovering trouble spots. Please refer to it when performing maintenance. Please use when inspecting inside the unit.

NO POWER

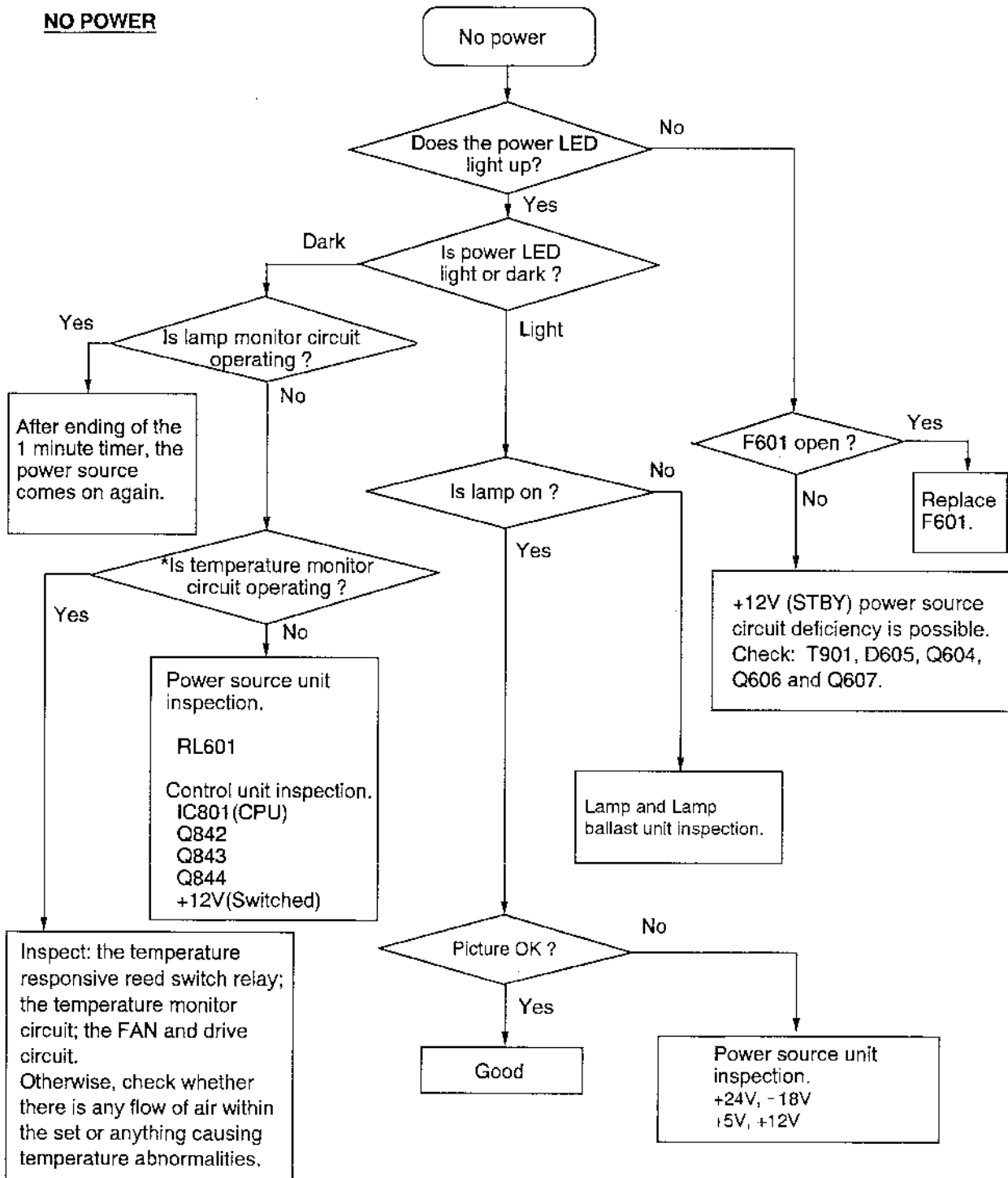

* The temperature responsive reed switch relay (SW904 and SW905) is ON under normal conditions.

NO PICTURE

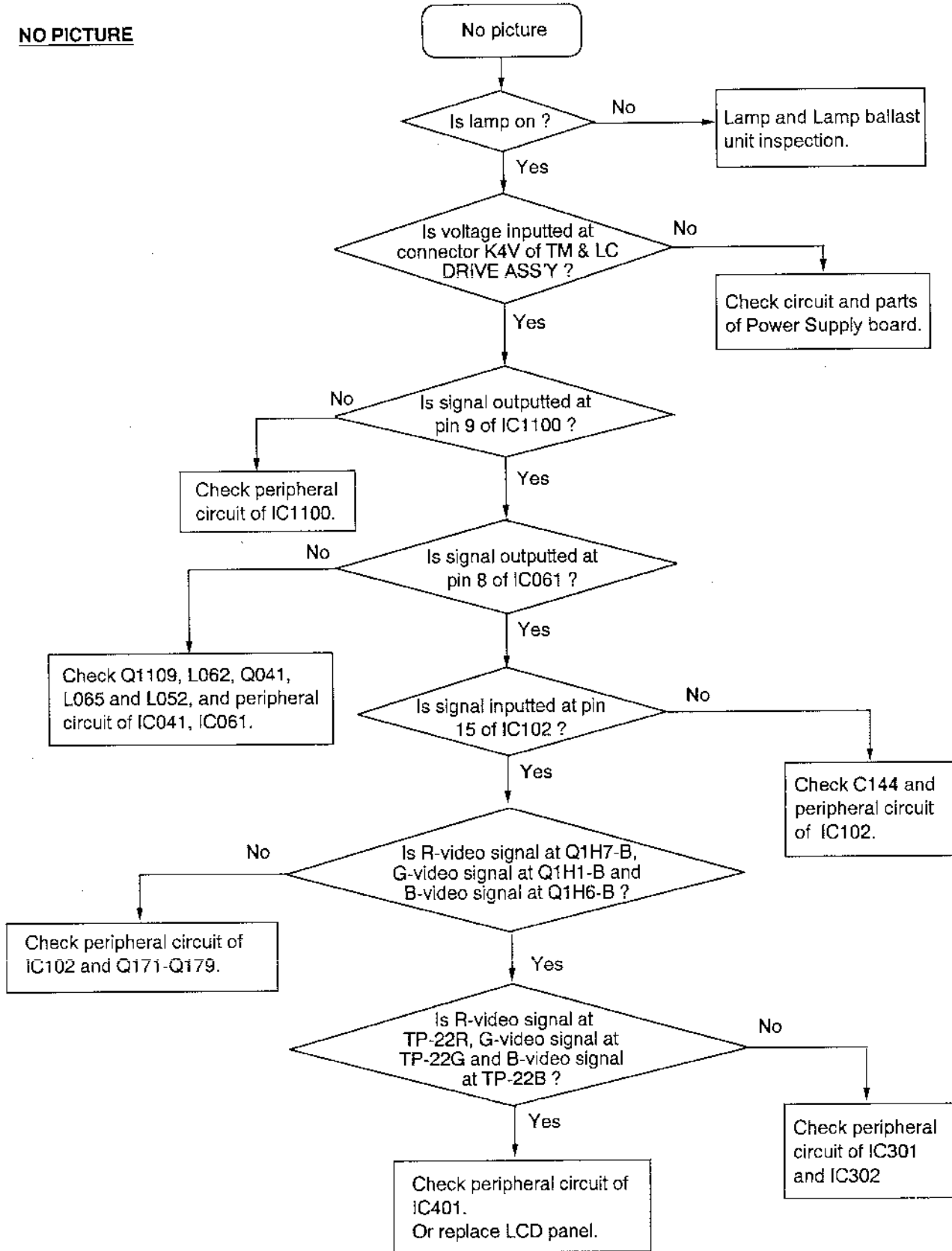

NO COLOUR

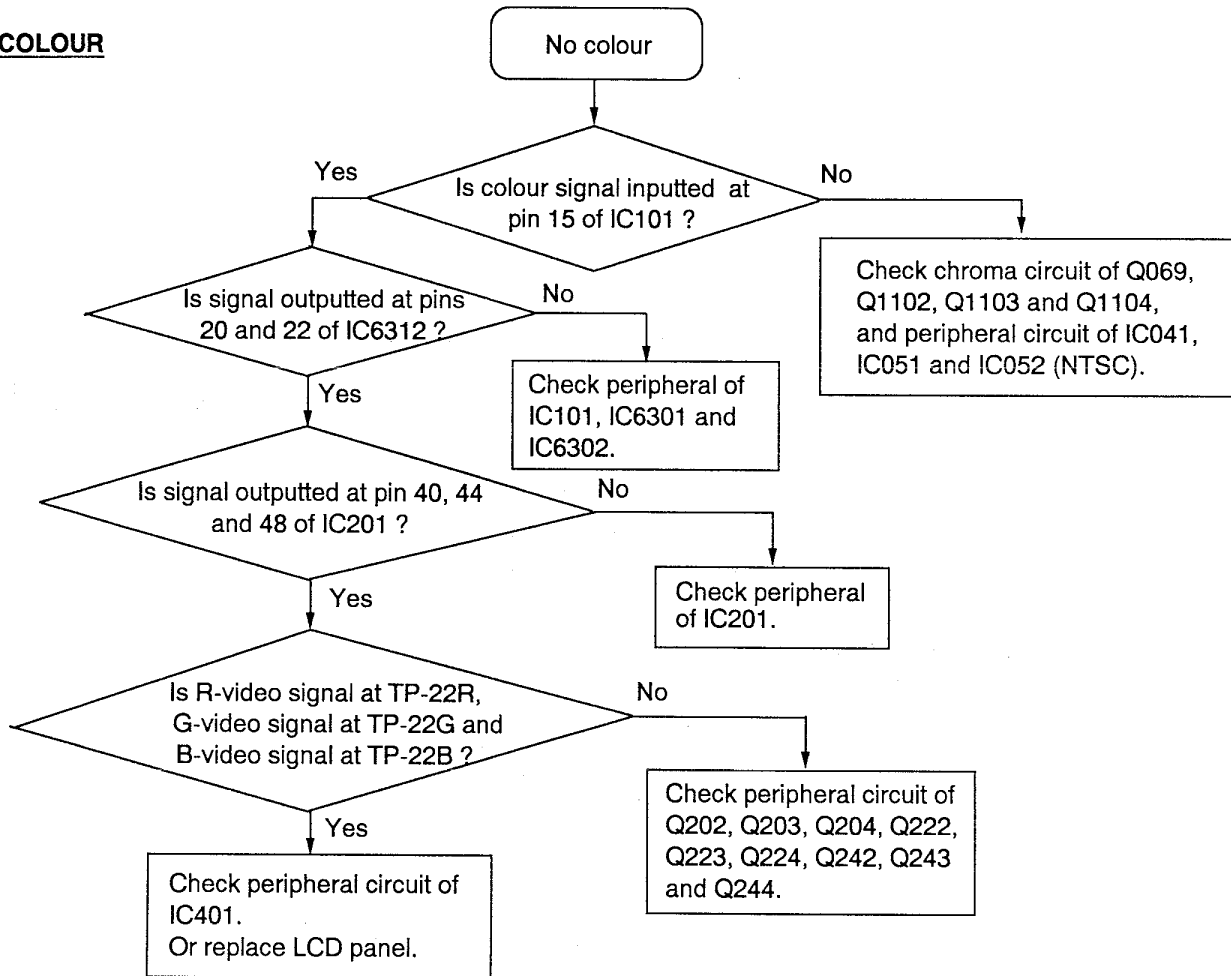

NO SYNCHRONIZATION

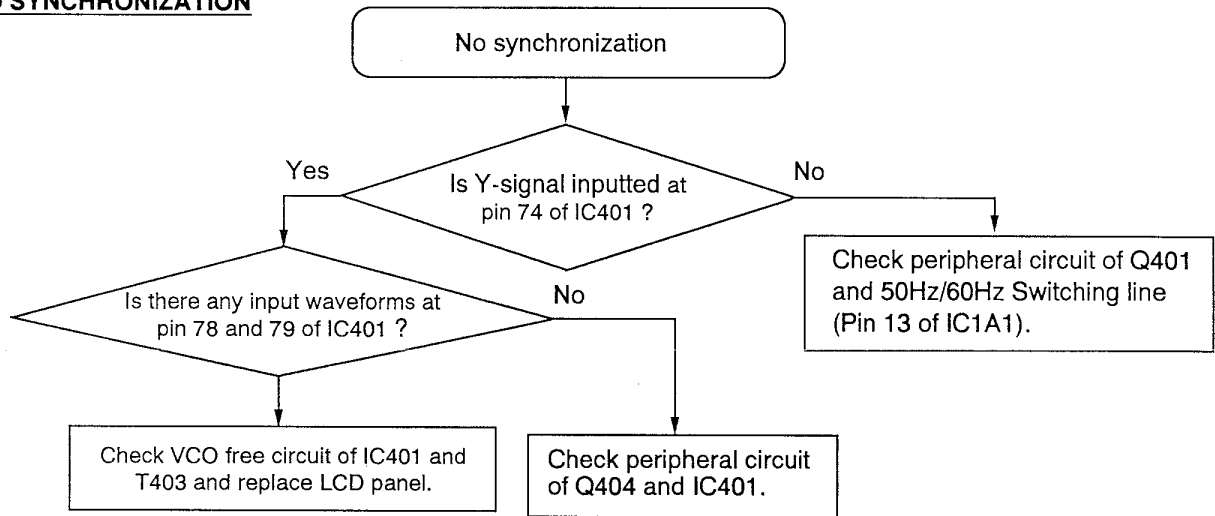

NO SOUND

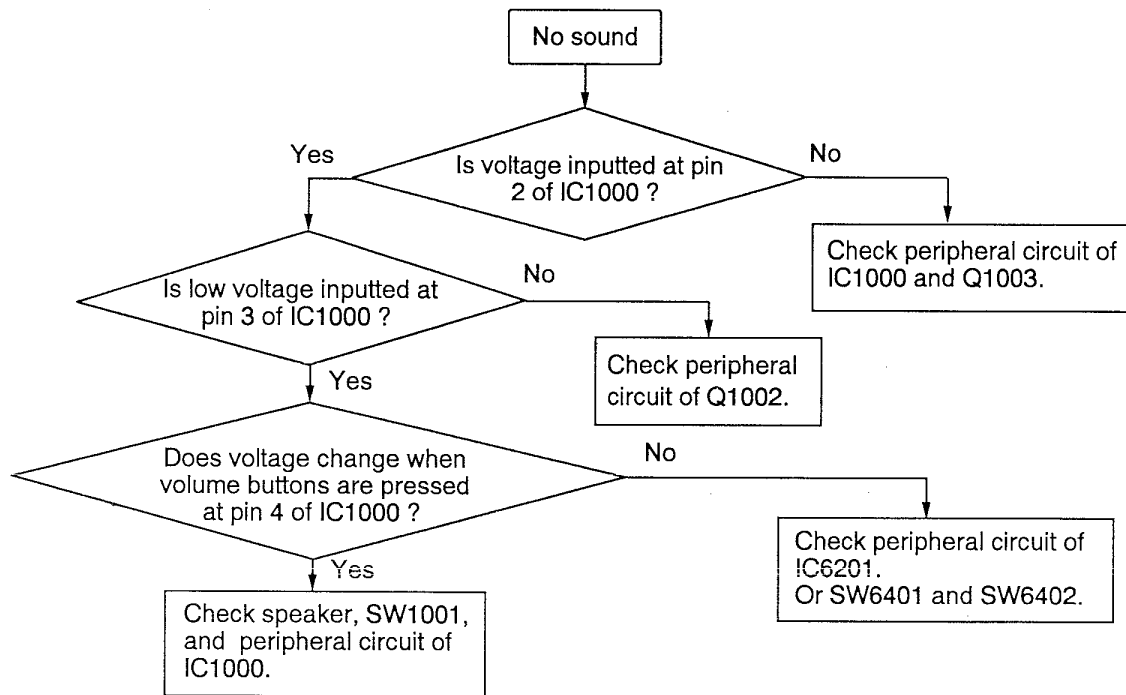

LAMP REPLACEMENT

WARNING

THIS LAMP IS OPERATED UNDER HIGH PRESSURE.

FOR CONTINUED SAFETY, REPLACE WITH A LAMP OF THE SAME TYPE.

UNPLUG THE PROJECTOR FROM THE POWER OUTLET BEFORE THE PROJECTION LAMP IS REPLACED.

DO NOT ATTEMPT TO CHANGE A HOT LAMP.

BE CAREFUL NOT TO TOUCH THE LAMP OR MIRROR WITH OILY FINGERS.

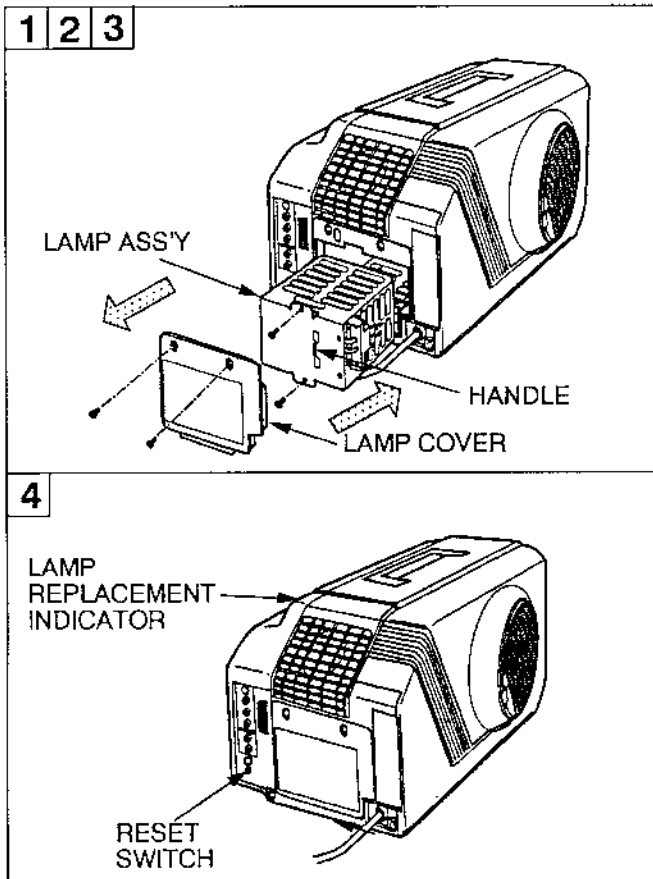

1

1. Remove 2 screws and lamp cover.

2

1. Remove 2 screws on the lamp ass'y.

2. Grip the handle and pull out the lamp ass'y carefully.

3

1. Replace with new lamp ass'y.

2. Install the lamp cover.

4

1. Connect the AC power cord to an outlet, and turn power on.

2. Wait 1 minute after turning power on.

3. Press the RESET SWITCH for 2 seconds.

Note: The "RESET" display will appear on the screen and the lamp replacement indicator disappears.

RECOMMENDATION

Should the air filter become clogged with dust particles, it will reduce the cooling fan's effectiveness and may result in internal heat build up and short lamp life. We recommend cleaning the air filter after the projection lamp is replaced.

Refer to AIR FILTER CARE AND CLEANING on the page 13.

HOW TO CHECK THE LAMP ILLUMINATION TIME

1. Checking procedure

With the projector in operating mode, press the LEVEL "+" or "-" button for 30 seconds; four red alphabets will appear on the screen for 5 seconds.

2. Calculation of illumination

$$A. \text{ ILLUMINATION TIME} = 1000 - \frac{8 \times (B \times 4096 + M \times 256 + F \times 16 + L)}{60}$$

(Setting time: 1000 hours)

$$B. \text{ ILLUMINATION TIME} = 2000 - \frac{8 \times (B \times 4096 + M \times 256 + F \times 16 + L)}{60}$$

(Setting time: 2000 hours
See page 5.)

Note: If the RESET button is pressed, the data of illumination time will be initialized.

3. Alphabet - number conversion table

A --- 0 B --- 1 C --- 2 D --- 3 E --- 4 F --- 5 G --- 6 H --- 7 I --- 8
J --- 9 K --- 10 L --- 11 M --- 12 N --- 13 O --- 14 P --- 15

4. Calculation example

$$1000 - \frac{8 \times (1 \times 4096 + 12 \times 256 + 5 \times 16 + 11)}{60} \approx 32$$

Approx. 32 hour of illumination

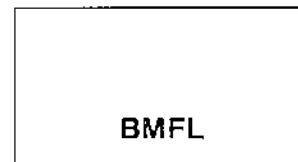

MECHANICAL DISASSEMBLIES

1

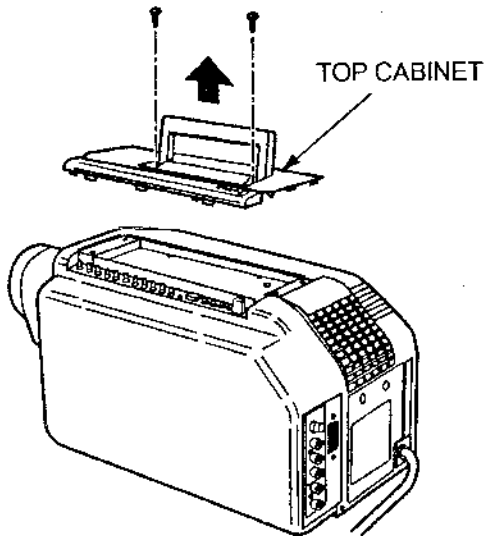

TOP CABINET REMOVAL

1. Remove 2 screws, on the top cabinet.
2. Then pull the top cabinet upward and remove.

2

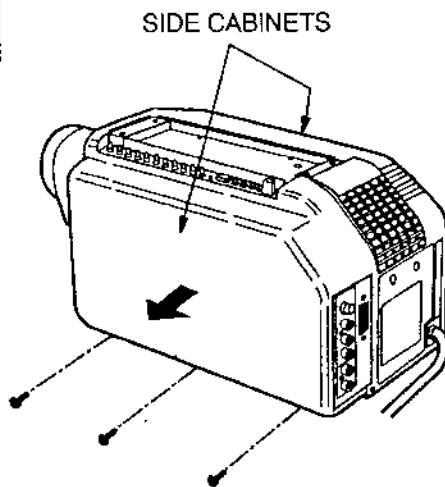

SIDE CABINETS REMOVAL

1. Remove 3 screws, on the bottom of the side cabinet.
2. Then pull the side cabinet sideward and remove.
3. Remove the another side cabinet, repeat steps 1 and 2.

3

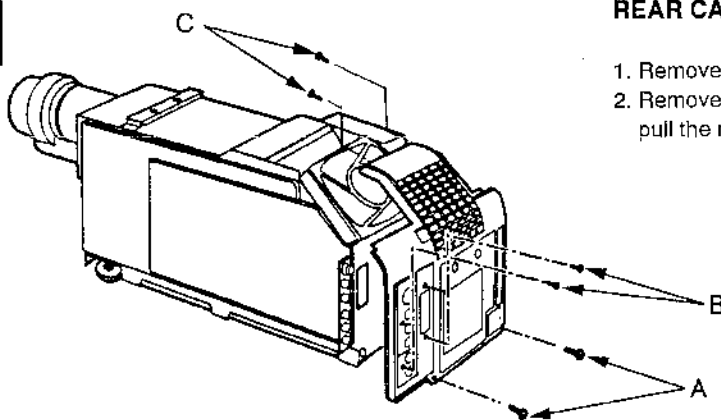

REAR CABINET REMOVAL

1. Remove 2 screws-A, then remove the lamp cover.
2. Remove 4 screws-B and remove 2 screws-C, then pull the rear cabinet backward and remove.

4

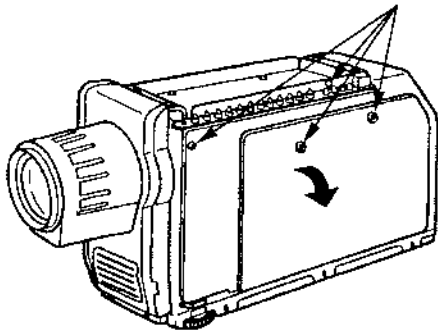

LEFT SIDE BOARD EXTEND

1. Remove 3 screws on the left side board and remove screw on LED supporter.
2. Gently extend the left side board sideward.

RIGHT SIDE CABINET

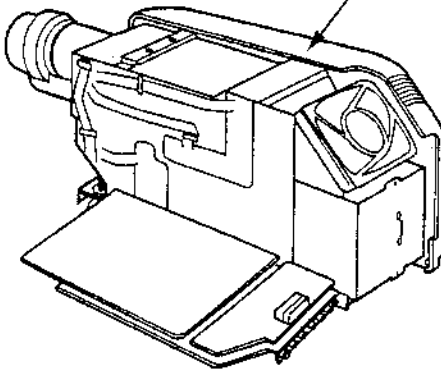

SERVICE NOTE

When you adjustment of every kind with projector on condition, to prevent dust coming into the projector, attach the right side cabinet to the projector certainly.

5

REMOVAL OF LCD PANEL ASS'Y

1. If changing the LCD panel ass'y, remove the 2 screws-A for the R-Panel, the 2 screws-B for the G-Panel, and the 2 screws-C for the B-Panel.
2. Unfasten the FPC from the wire holders and disconnect FPC from the FPC connector on main board.
3. Then remove the LCD panel ass'y from the panel retainer.

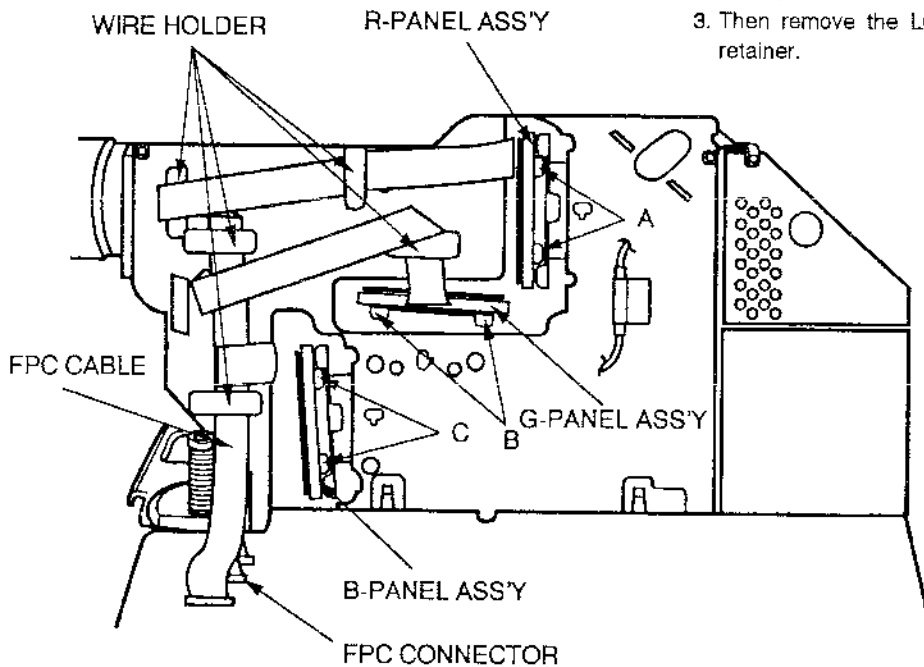

FPC CONNECTOR

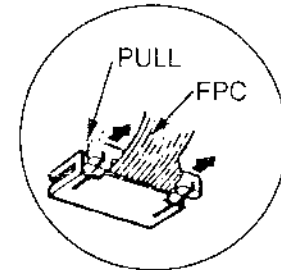

6

TOP HOLDER

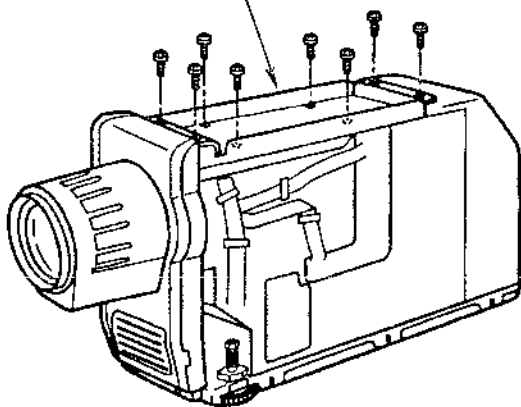
**TOP HOLDER REMOVAL**

1. Remove 8 screws on the top holder.
2. Then pull the top holder upward and remove.

7

FRONT CABINET

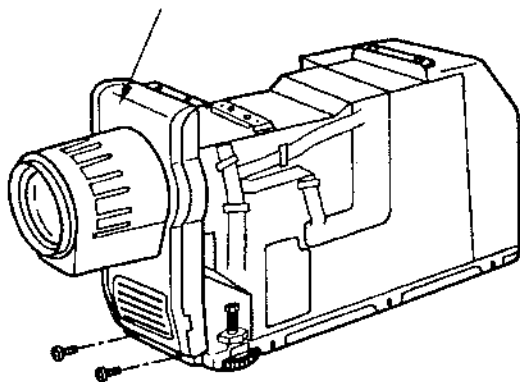
**FRONT CABINET REMOVAL**

1. Remove 2 screws on the front cabinet.
2. Gently slide the front cabinet, then remove screw on the remote control pre-amp. holder and remove 4 screws on the speaker.
3. Then pull the front cabinet forward and remove.

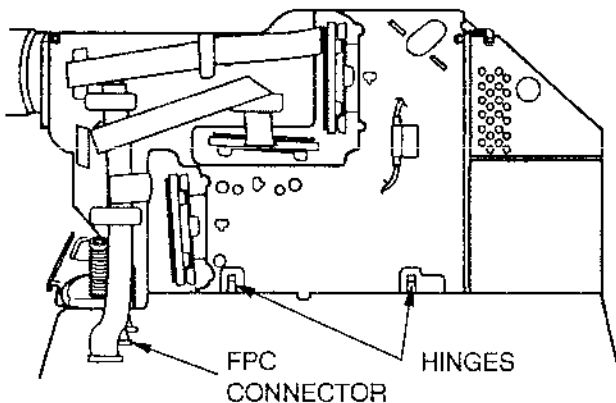
8**LEFT SIDE BOARD REMOVAL**

1. Disconnect the 3 FPC from the FPC connector on board.
2. Push the 2 Hinges, then remove from the board.
3. Disconnect the connectors "K4V", "K8M", "K8J", "K8U", "K8T", "K10H" and "K10T" from the board.

9**SUB POWER BOARD REMOVAL**

Remove 2 screws on the sub power board.
Then remove the sub power board.

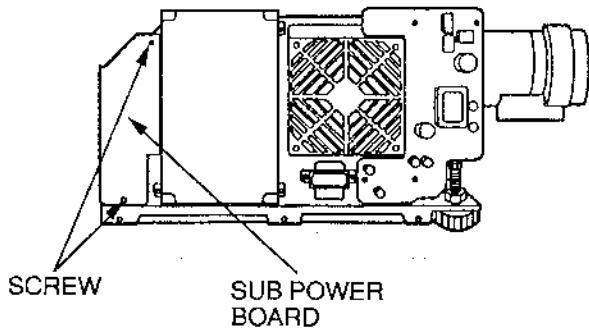
**10****LAMP BALLAST UNIT REMOVAL**

1. Remove 3 screws-A on the lamp ballast unit.
2. Remove lamp ass'y. (Refer to LAMP REPLACEMENT on the page 18.)
3. Remove 2 screws-B on the lamp socket.
4. Disconnect the Connectors "K6F" and "K8D" from other board.
5. Remove 3 screws-C, then pull out the cover and remove.
6. Remove 4 screws-D, on the corner of the lamp ballast board ass'y.
7. Remove the lamp ballast board ass'y from the case.

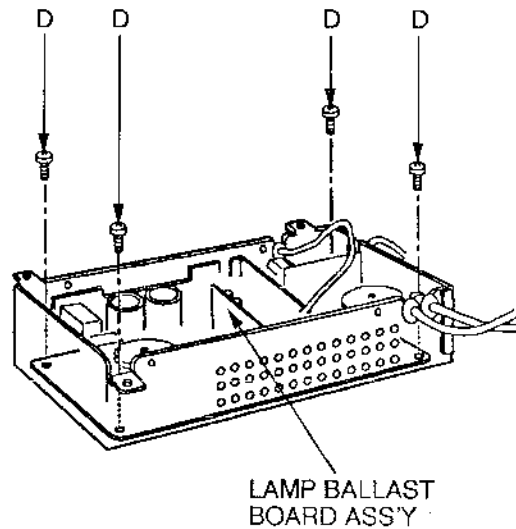
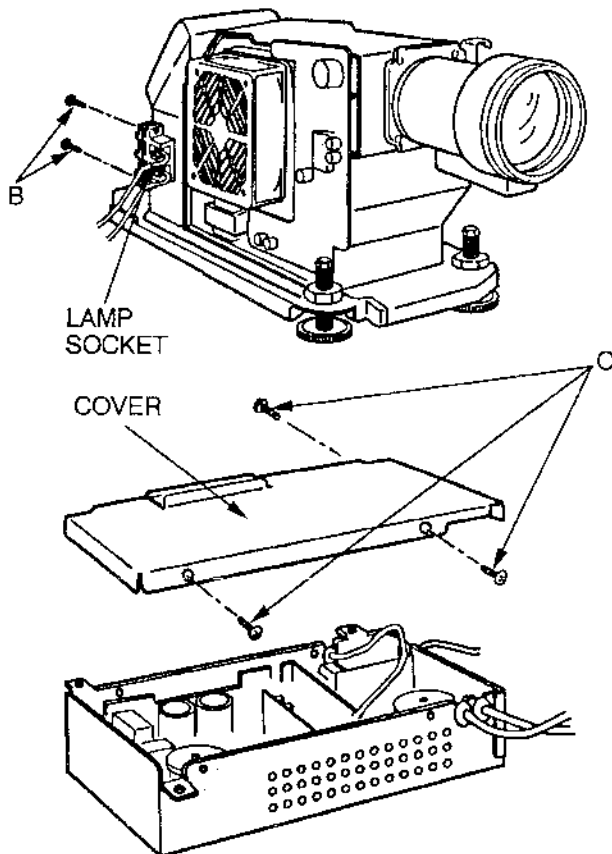
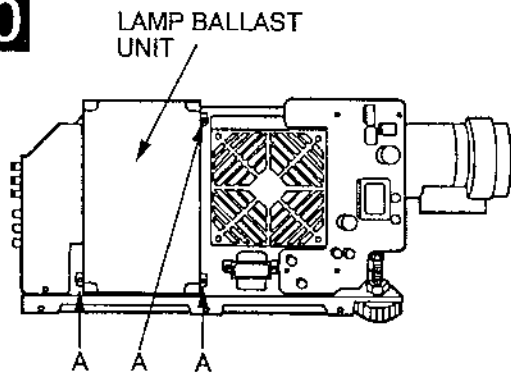

11

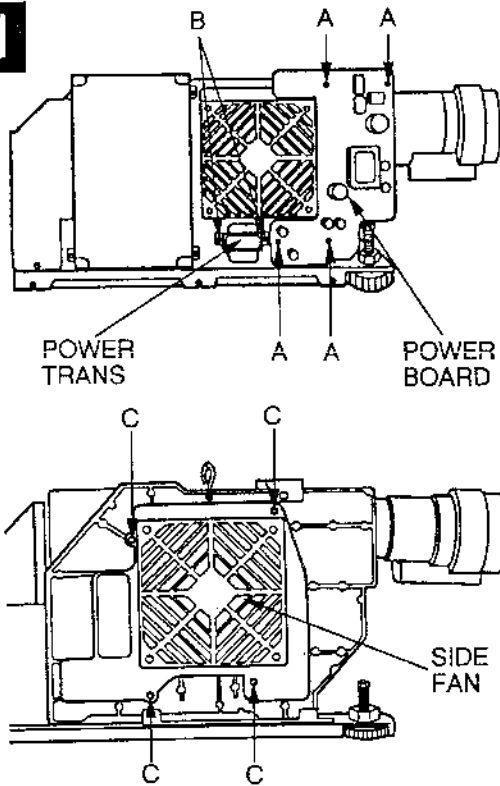

POWER BOARD REMOVAL

Remove 4 screws-A on the power board. Then remove the power board

POWER TRANS REMOVAL

Remove 2 screws-B on the power trans. Then remove the power trans.

SIDE FAN REMOVAL

Remove 4 screws-C on the side fan. Then remove the side fan.

12

LCD UNIT REMOVAL

1. Remove 4 screws on the bottom of the LCD unit.
2. Then pull the LCD unit upward and remove from bottom cabinet.

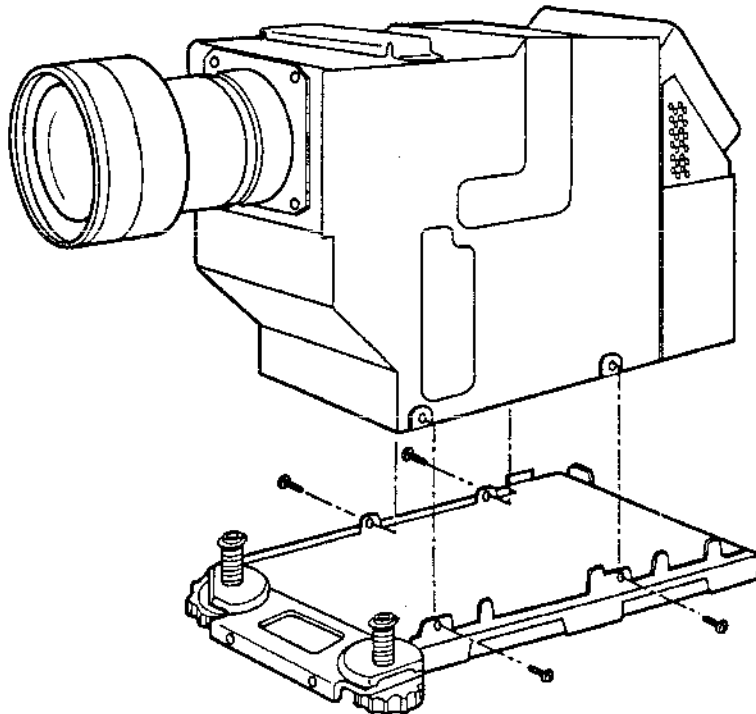

13

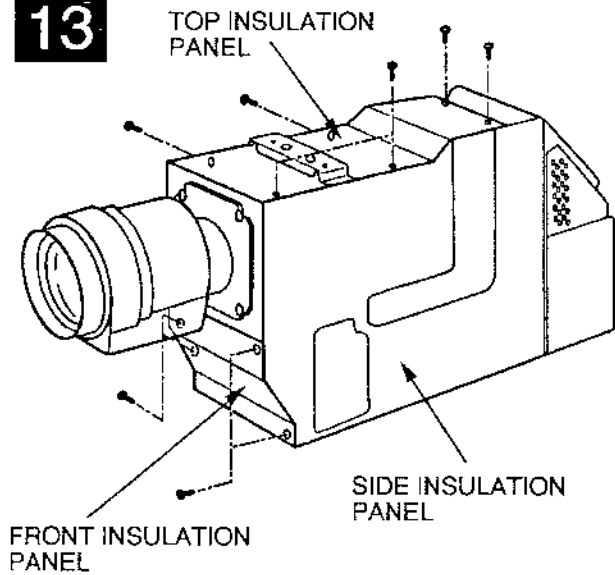

INSULATION PANEL REMOVAL

TOP INSULATION PANEL REMOVAL

1. Remove 6 screws on the top insulation panel.
2. Then pull the top insulation panel upward and remove.

FRONT INSULATION PANEL REMOVAL

1. Remove 4 screws on the front insulation panel.
2. Then pull the front insulation panel forward and remove.

SIDE INSULATION PANEL REMOVAL

1. Unfasten the FPC from the 5 wire holders.
2. Remove 9 screws (large, ●), 13 screws (small, ⊕) and 6 screws (with washer, ⊕) on the side insulation panel.
3. Then pull the side insulation panel sideward and remove.

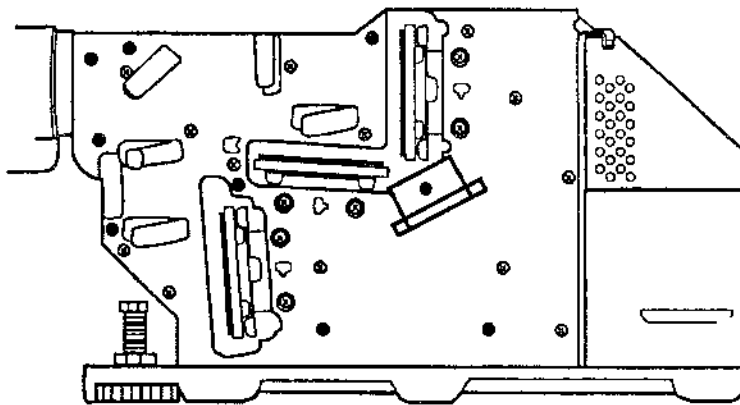

POSITIONING OF LCD PANELS AND MIRRORS

DICROIC MIRROR USED FOR GREEN MIXING (coating face is outer side)

ALUMINUM FULL REFLECTION MIRROR (coating face is outer side)

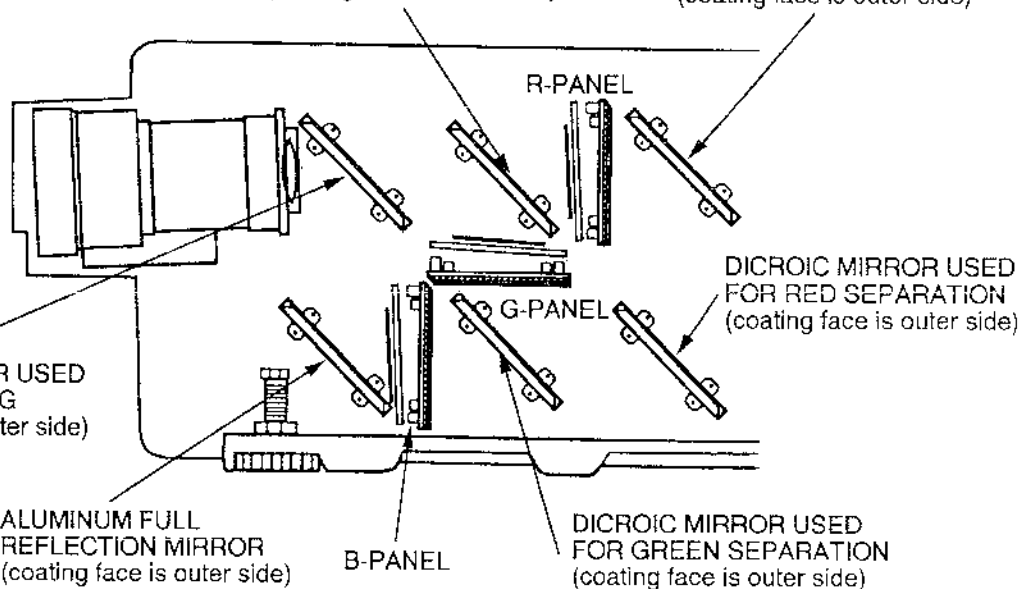

14

LENS REMOVAL

1. Keep holding the lens and remove 4 screws fixing the lens.
2. Remove the lens from the unit.

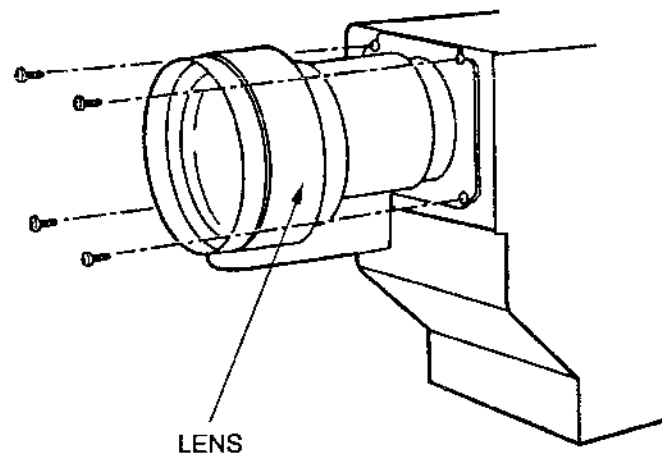

15

REMOTE CONTROL TRANSMITTER DISASSEMBLY

1. Remove the screw.
2. Push and pull the battery compartment lid, and remove the battery compartment lid.
3. Insert slot type screwdriver to the space of cabinet bottom and cabinet top (1-5), and twist it. Then pull the cabinet bottom (6-10), and remove the cabinet bottom.

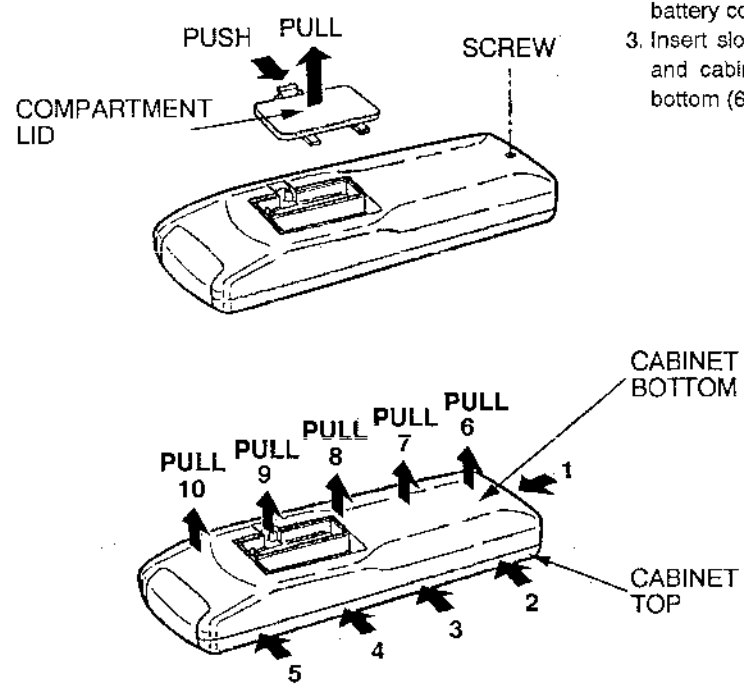

LCD PANEL ASS'Y REPLACEMENT

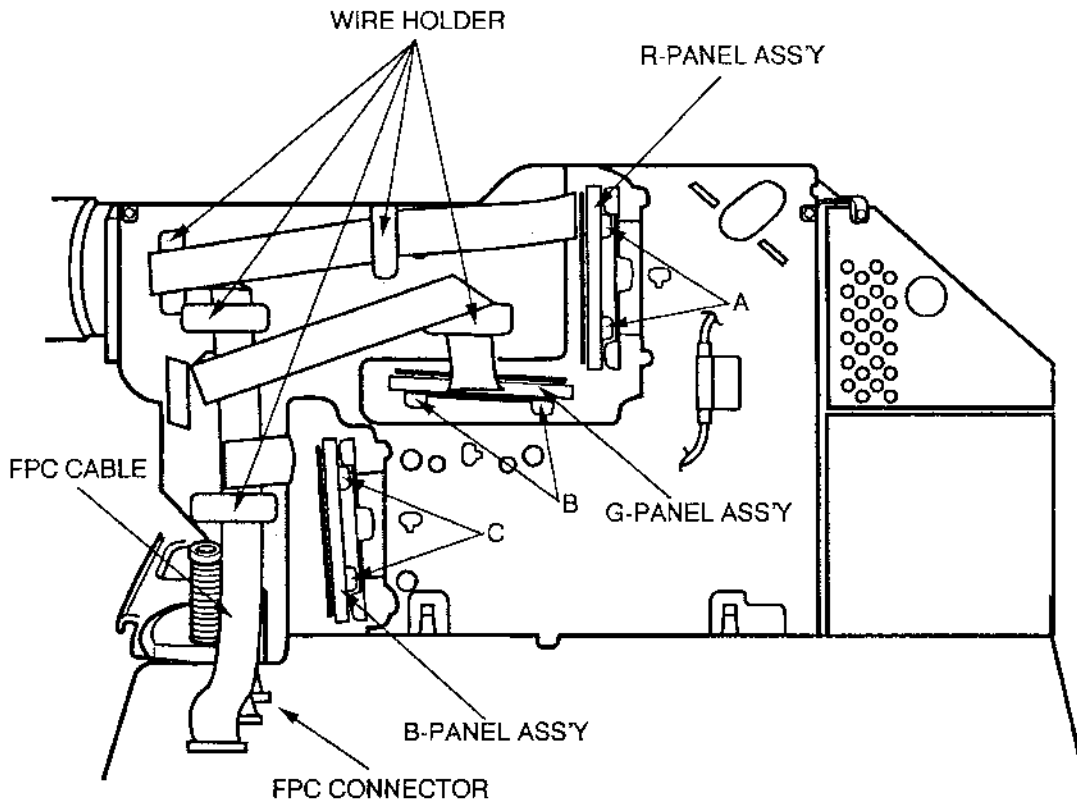

FPC CONNECTOR

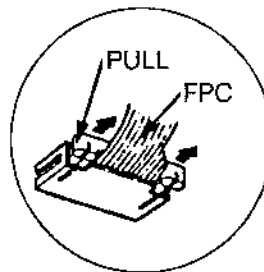

1. Changing the LCD Panel Ass'y, remove the 2 screws-A for the R-Panel, the 2 screws-B for the G-Panel, and the 2 screws-C for the B-Panel.
2. Unfasten the FPC from the wire holders and disconnect FPC from the FPC connector on main board.
3. Then remove the LCD panel from the panel retainer.
4. For installation of the new panel, reverse the above procedures.

After replacing an LCD panel, check the focus (refer to Focus Adjustments) and adjust the convergence (refer to Convergence Adjustment).

When replacing the R - LCD panel, check the R focus and adjust the convergence.

When replacing the B - LCD panel, check the B focus and adjust the convergence.

When replacing the G - LCD panel, after checking the G focus, also check the R and B convergence.

Adjust the R and B convergence if either one is out of alignment. (Alignment of G with R and B can also be made by adjusting the position of the G panel.)

LCD PANEL REPLACEMENT

1. Remove the LCD panel assembly by following steps 1-3 of the LCD PANEL ASS'Y REPLACEMENT procedure on page 27 on this manual.
2. Disassemble the LCD panel assembly by removing the 4 screws. (See Fig. 1 and 2.)
3. Replace the LCD panel and reassemble the panel assembly. Then, adjust the polarizing glass following the procedure given below.

POLARIZING GLASS ADJUSTMENT

1. Connect the FPC cable to the LCD panel assembly.
2. Using a light source, such as a fluorescent lamp, illuminate the polarizing glass from the "A" direction (the side which is not adjusted). See Fig. 1 and 2.
3. With no signal applied to the projector, turn on the power.
4. Loosen the 3 mounting screws that hold the polarizing glass. (See Fig. 3.)

Rotate the polarizing glass until a minimum of light passes through the glass (the light is darkest), then tighten the 3 screws.

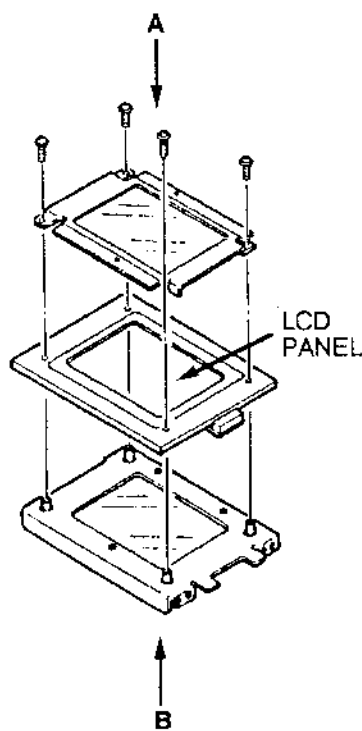

Fig. 1 GREEN PANEL

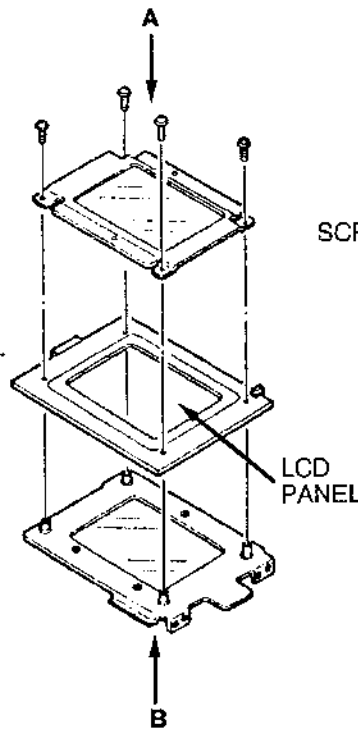

Fig. 2 RED/BLUE PANEL

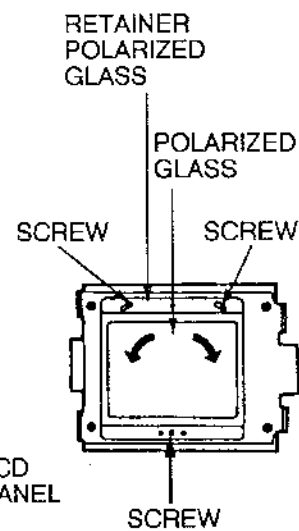
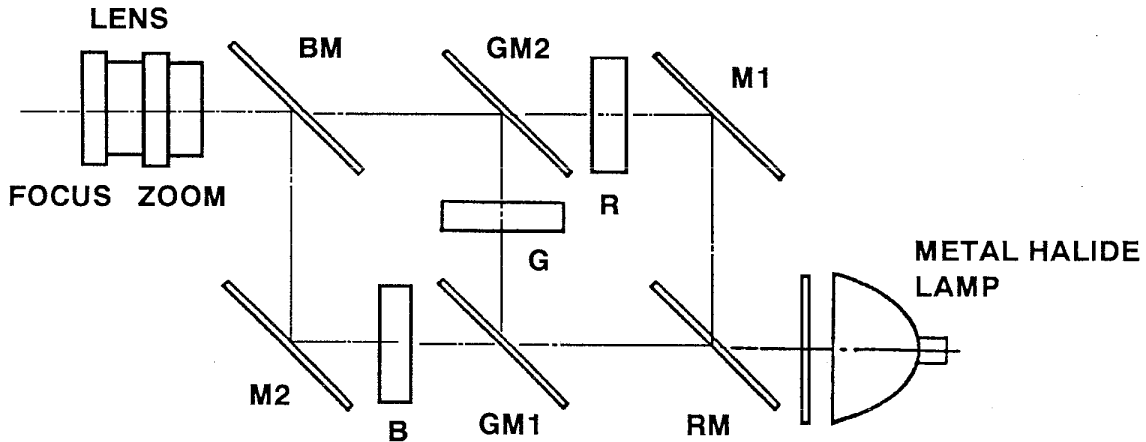

Fig. 3
POLARIZING GLASS
ADJUSTMENT

OPTICAL ADJUSTMENTS



Optical path adjustment

● Preparation before adjustment.

1. Place lamp, M1, M2, BM, GM1, GM2, RM and lens at right position.
2. Make sure that M2, BM, GM2, RM is placed at 45 degree with optical path and 90 degree with base.

● Optical path adjustment.

1. Turn the lamp on and place screen in front of projection lens and show the lamp image on the screen.
2. If the blue lamp image is off from the green lamp image at 90 degree angle (vertical) when masking the red lamp, rotate GM1, and if the lamp image is off at horizontal direction, adjust mounting angle against base.
3. If the blue lamp image is off from the red lamp vertically when masking the green lamp, rotate M1 and if that is horizontal, adjust mounting angle against base.

This adjustment is only for R.G.B. optical path, and not for centering the beam.

FOCUS ADJUSTMENTS

When conducting focus adjustment, first adjust the G (green) LCD panel unit as the standard reference. Next align the focus for R (red) and B (blue) by adjusting the position of each panel unit.

For adjustment, the setting configuration for the unit is as shown in Fig.1, Fig.2 and Fig.3.

The pattern signal used for adjustment should be a pattern in which the R, G and B dots are easily distinguishable. (A flat pattern, etc.)

G-LCD Panel Unit Position Adjustment (G Focus Adjustment)

1. Turn on the power to the unit, and project the adjustment pattern on the screen.
2. Insert paper, etc. in locations B and C as indicated in Fig.1 to block the B light and R light, and project only the G light. Set the focus control to initial (mid) position and set zoom control to minimum position use control on RC transmitter or projector.
3. Loosen screws "1" (Fig.1) and screws "2" (Fig.2). Move the G panel unit up or down until the middle right side of the screen is in sharp focus. For adjustment, insert a slot head screwdriver in the adjustment slot "a"(Fig.1). In case of unable to adjust, permit to adjust focus by focus control on RC transmitter or projector.
4. In the same manner, use the slot "b"(Fig.2) and adjust the top left side of the screen is in sharp focus.
5. Then use the slot "c"(Fig.2) and adjust the bottom left side of the screen is in sharp focus.
6. Set zoom control to maximum position. Repeat steps 3-5 until the G focus is in the best position possible, then tighten screws "1" and "2".

R-LCD Panel Unit Position Adjustment (R Focus Adjustment).

Before conducting the R focus adjustment, make sure the G focus adjustment has already been completed.

1. Insert paper, etc. in locations A and B as indicated in Fig.1 to block the G light and B light, and project only the R light.
2. Loosen screws "3" (Fig.1) and screw "4" (Fig.3). Move the R panel unit forward or backward until the middle right side of the screen is in sharp focus. For adjustment, insert a slot head screwdriver in the adjustment slot "d"(Fig.1).
3. In the same manner, use the slot "e"(Fig.3) and adjust the top left side of the screen is in sharp focus.

4. Then use the slot "f"(Fig.3) and adjust the bottom left side of the screen is in sharp focus.

5. Repeat steps 3-5 until the R focus is in the best position possible, then tighten screws "3" and "4".

B-LCD Panel Unit Position Adjustment (B Focus Adjustment).

Before conducting the B focus adjustment, make sure the G focus adjustment has already been completed.

1. Insert paper, etc. in locations A and C as indicated in Fig.1 to block the G light and R light, and project only the B light.
2. Loosen screws "5" (Fig.1) and screw "6" (Fig.3). Move the B panel unit forward or backward until the middle right side of the screen is in sharp focus. For adjustment, insert a slot head screwdriver in the adjustment slot "g"(Fig.1).
3. In the same manner, use the slot "h"(Fig.3) and adjust the top left side of the screen is in sharp focus.
4. Then use the slot "i"(Fig.3) and adjust the bottom left side of the screen is in sharp focus.
5. Repeat steps 3-5 until the B focus is in the best position possible, then tighten screws "5" and "6".

* Sharp Focus ---- A single dot being clearly distinguishable on the screen.

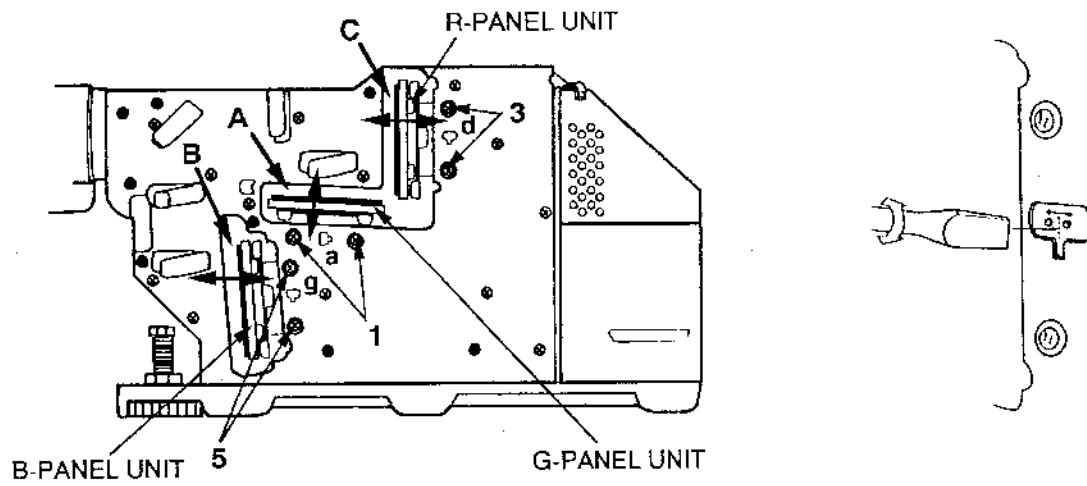

Figure 1

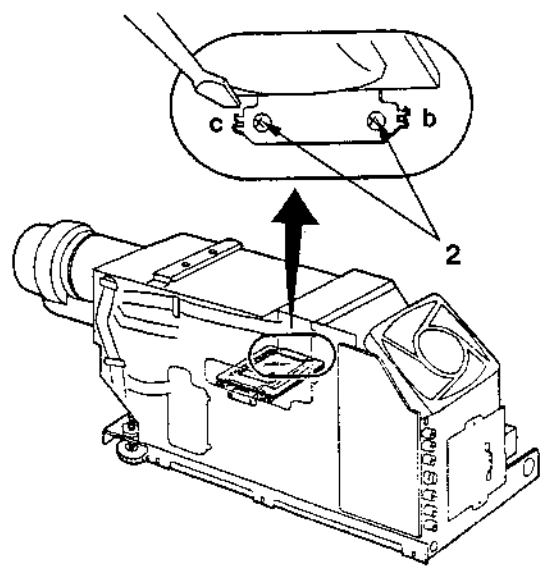

Figure 2

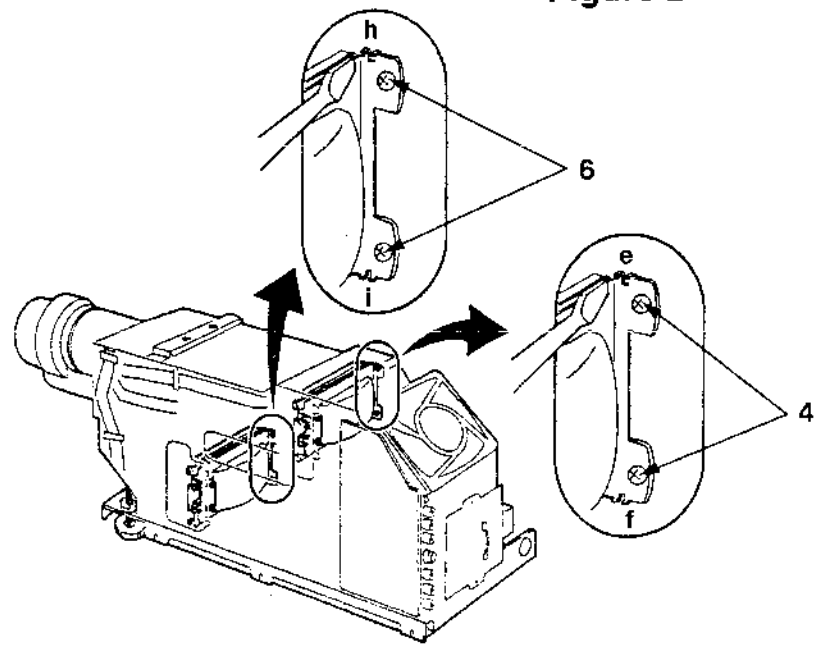

Figure 3

CONVERGENCE ADJUSTMENTS

For convergence adjustment, with G (green) as the reference standard, align R and B by adjusting the position and angle of the R (red) and B (blue) LCD panels.

Before Adjustment:

Make sure each R, G, B LCD panel unit has been correctly installed, and that all focus adjustments have been completed before performing convergence adjustments. (See Focus Adjustments)

Below is an explanation regarding adjustment screws and panel movement.

4 Screws "1" shown in Fig.2, hold the LCD panels in place (hex hole screws).

Screws "A", "B" and "C" shown in Fig.2 are for convergence adjustment.

The movement of the R and B patterns using the "A", "B" and "C" screws is as follows:

R Panel Adjustment

1. Insert paper, etc. in location A shown in Fig.1 to block the B light.
2. Loosen 4 screws "1" on the R panel. (Refer to Fig.2)
3. Using screws "A" and "B" (Fig.2), align the R grid pattern vertical center line parallel with the G grid pattern vertical center line (at this time the horizontal line will also be parallel).
Adjust the "A", "B" screws with a slot type screwdriver.
4. Turn both "A" and "B" screws in the same direction to align the R vertical center line on top of the G vertical center line. Repeat procedures 3 and 4 if necessary.
5. Turn screw "C" by slot type screw driver to align the R horizontal center line on top of the G horizontal center line.
6. By repeating steps 3 thru 5, align the R grid pattern directly on top of the G grid pattern.
Convergence adjustment is always made on the center of the grid pattern. There may be some color misalignment on the periphery of the screen.
7. Tighten the R panel screws "1" when adjustment has been completed.

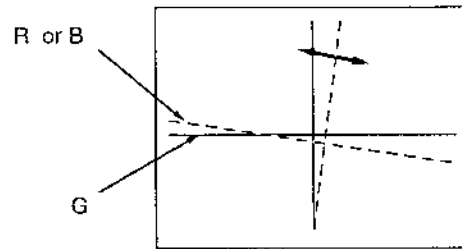

Screw A

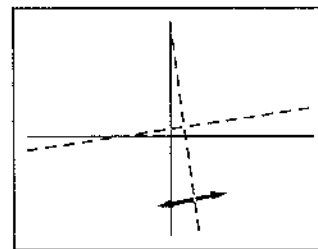

Screw B

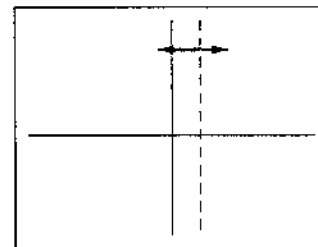

Screws A and B

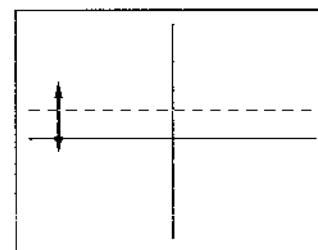

Screw C

B Panel Adjustment

1. Insert paper, etc. in location B shown in Fig.1 to block the R light.
2. Loosen 4 screws "1" on the B panel. (Refer to Fig.2)
3. The adjustment procedures for aligning the B grid pattern on top of the G grid pattern are the same as those for the R panel.

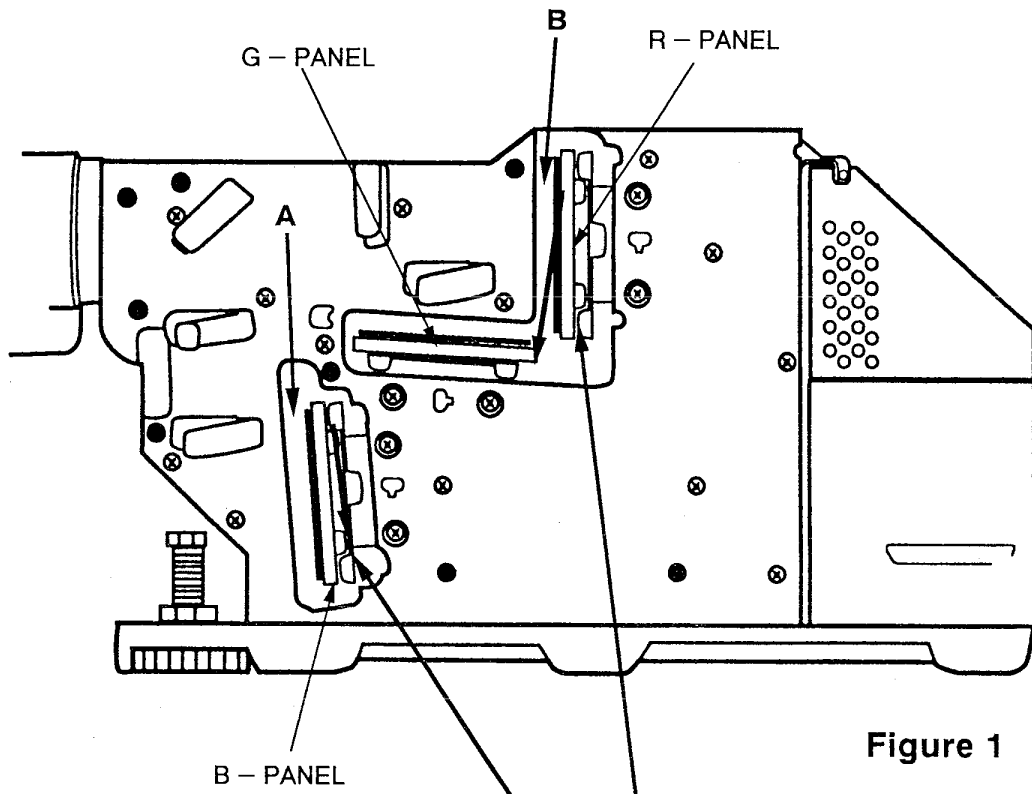

Figure 1

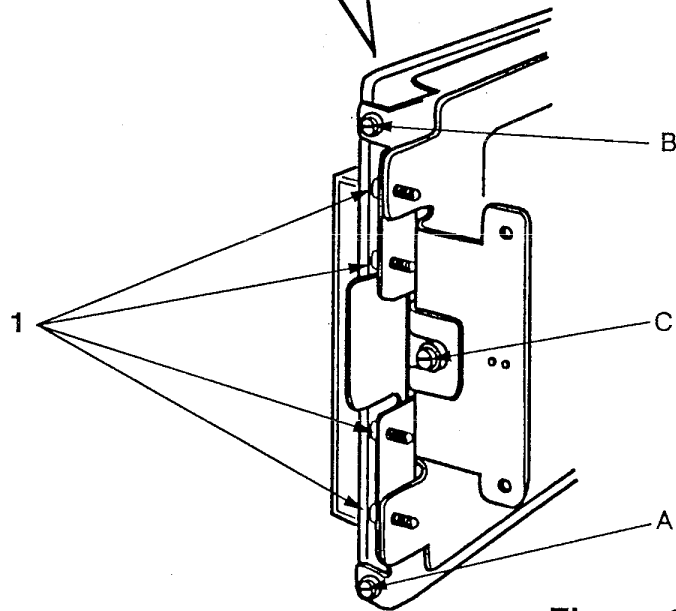

Figure 2

CLEANING METHODS

After long periods (many years) of use, dust and particles and other contamination will accumulate on the LCD panel Ass'y (LCD panel and polarizing plate), lens, mirror, etc. and the picture will tend to darken and color blurring may occur. When this occurs, cleaning of the inside of the unit will be necessary. For dust and light accumulation of contamination, use an air spray to remove the dust. If the contamination cannot be removed by air spray, disassembly and cleaning of the unit will be necessary. Perform all cleaning according to the cleaning methods given below.

Caution:

Use a commercial (insert gas) air spray designed for camera cleaning use. Never use any cleaner other than that specified for cleaning the LCD panel Ass'y (LCD panel and polarizing plate), lens, mirror, etc. Also, never scrape with any hard material as this will cause damage.

Air Spray cleaning Method

Remove dust from the LCD panel Ass'y by inserting the air spray nozzle in the openings on both sides of the sets holding the LCD panel Ass'y. (Caution: Always use a nozzle made of resin. Also be very careful not to cause any damage to the LCD panel assembly parts with the nozzle tip.)

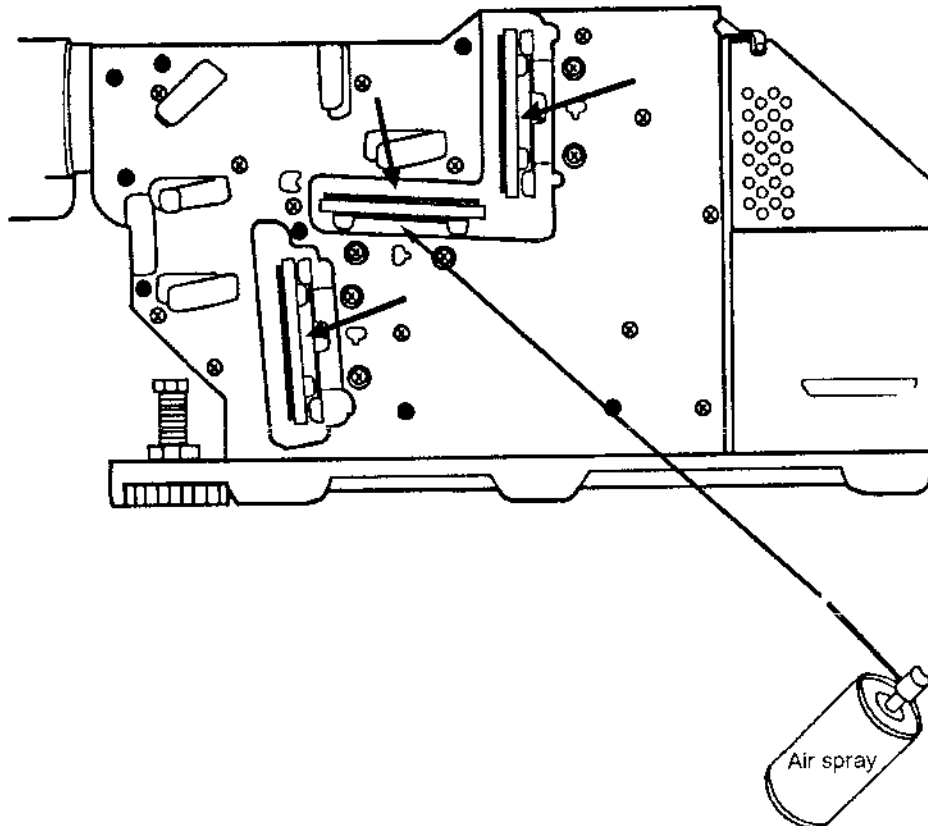

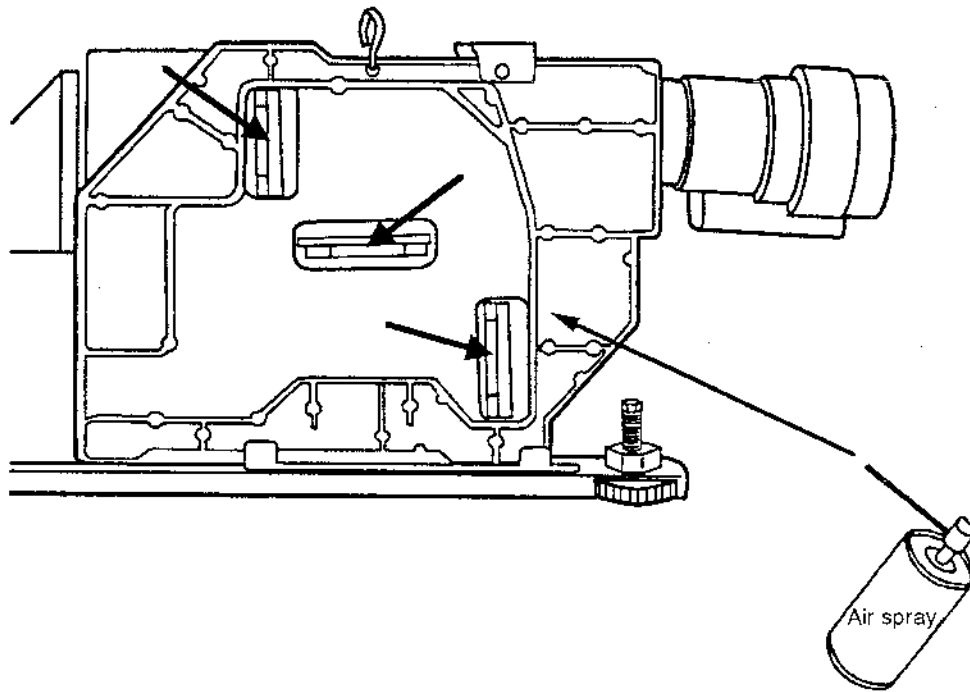

Disassembly cleaning Method

After performing disassembly cleaning, adjustment of the unit will be necessary.

Disassembly cleaning should only be performed when there is considerable contamination which cannot be removed by air spray.

Caution:

Never remove the mirror. The position of the mirror is precisely set at the factory. Perform all cleaning of the mirror with it attached to the unit.

Disassemble and clean the LCD panel units.

Disassembly and assembly of the LCD panel units is performed according to the exploded view diagrams given for each panel, cleaning of the mirror is always performed with it attached to the main unit.

Perform the cleaning of each part according to the cleaning methods described below.

● **LCD Panels Ass'y (LCD panel and polarizing glass lens)**

Remove dust, etc. by wiping with a soft cloth. For heavy contamination, remove by moistening the cloth with alcohol.

Caution:

Never use organic solvents (thinners, etc.) as their use will cause damage to these surfaces.

Never use water or other liquids on the LCD panels ass'y. If the liquid gets into the circuits, damage will result.

● **Mirrors**

Remove dust, etc. by wiping with a soft cloth. For heavy contamination, remove by moistening the cloth with alcohol.

Caution:

Never use organic solvents (thinners, etc.) as their use will cause damage to these surfaces.