

3M™ Digital Projector X45



- An elegant design to help you win your audiences!
- Relax. Backed by 3M's quality, reliability, and 24/7 technical support.
- Versatile — for work or for home cinema.
- Wide range of computer and video connections.

Official Designer of Ferrari for over 50 years.



CONNECTIONS

COMPUTER

- RGB (x2 input, x1 output)
- USB mouse emulation
- Serial Control

VIDEO

- Composite Video
- Component Video
- S-Video

BASIC SPECS

- 1,500 ANSI lumens
- XGA (1024x768)
- 5.8 lbs / 2.65 kg
- Vertical Digital keystone
- HDTV ready

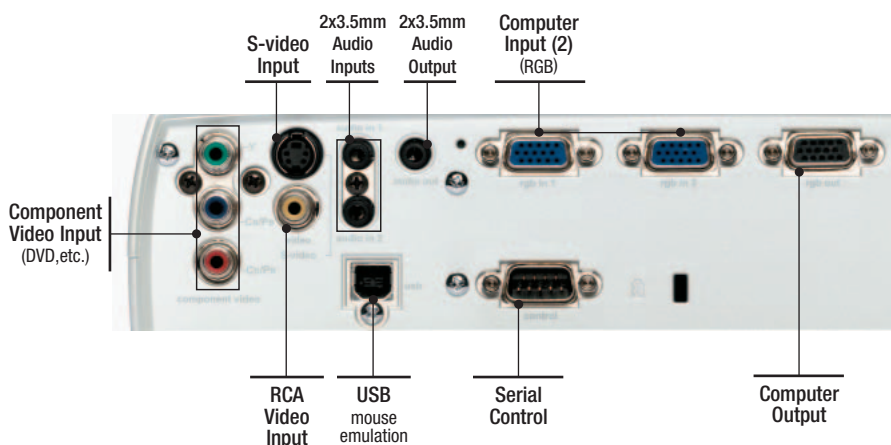

X45 Order Number: 78-9236-6837-6



1-800-328-1371
www.3m.com/meetings

3M Innovation

3M™ Digital Projector X45



Optical

- Brightness: typical : 1,500 lumens (1,200 whisper mode)
- Imager set: 0.7" Polysilicon LCD
- Resolution (native): XGA (1024x768 pixels)
- Resolution (maximum): WXGA (1680x1200 pixels)
- Aspect ratio: 4:3 native, 16:9
- Colors: 16.7 million
- Screen size (range): 30-301 inches
- Zoom / Focus: Manual
- Zoom ratio: 1.2: 1
- Projection lens: F (focal length): (1.7-1.9) (f =21.8-26.2 mm)
- Optional lenses: No
- Contrast ratio (peak): 400:1
- Lamp: W, Type: 165w UHB
- Lamp life (average): 2,000

Electrical

- Video compatibility: NTSC, NTSC 4.43, PAL, PAL-M, PAL-N, SECAM
- HDTV: 480i, 480p, 525i, 525p, 720p, 1080i
- Keystone Correction: Vertical: ±10°
- Audio: 1 x 1w
- Startup Screen: customizable
- Noise level: normal (whisper): 41 (35) dB
- Feature set: Auto off, 4x digital magnification, blank, mouse emulation, progressive scan
- Horizontal scan: 31.5-91 kHz
- Vertical scan: 56-120 Hz
- Power consumption: 240w
- Power supply: Universal: 90-132V / 198-264V (50/60 Hz)
- Regulatory approvals: UL, cUL, FCC Part 15 Class B, CE, TUV, EN60950
- Operating temperature: 32 - 95 F (0 - 35 C)
- Storage temperature: -4 - 140 F (-20 - 60 C)

Size

- Dimensions (W x H x D): 12.2 x 10 x 3.5 in. (30.8 x 8.6 x 25.2 cm)
- Weight: 5.8 lbs / 2.65 kg

Warranties

- Projector: 3 Years Standard
- Ultra Value Warranty available—includes free lamp and free loaner while unit is repaired and expedited service.
- Lamp: 1 Year Prorated

Accessories included

- Power Cords (x3 - US, UK, Euro)
- RGB computer cable
- Remote control
- Swivel Base
- Multilanguage Quick Start Guide
- Multilanguage Operator's Guide CD
- Soft side bag

Optional Accessories

- Ultra Value Warranty X45 (WS45) 78-6969-9788-7
- Lamp X45 78-6969-9790-3
- Ceiling Mount, Gyrolock style (CM45/55) 78-6969-9791-1
- 26-47" Adjustable Extension for GyroLock Style Ceiling Mount (HE100) 78-6969-9698-8
- Soft Carry Case with Shoulder Strap - Projector & Notebook Computer (CC10/40/50) 78-6969-9715-0
- ATA Rolling Hard Shipping Case (HSC10/40/50) 78-6969-9717-6
- Soft Rolling Luggage Case (Projector & Notebook Computer) (SSC10/40/50) 78-6969-9716-8

PROJECTION DISTANCE CHARTS — 3M X45

| Distance to Screen | | Screen Size | | |
|--------------------|------------------|-------------------|-------------------|-------------------|
| Minimum | Maximum | Diagonal | Width | Height |
| 3.92ft. 1.2m | 4.67ft. 1.4m | 40in. 101.6cm | 32in. 81.3cm | 24in. 61.0cm |
| 5.92ft. 1.8m | 7.08ft. 2.2m | 60in. 152.4cm | 48in. 121.9cm | 36in. 91.4cm |
| 7.87ft. 2.4m | 9.51ft. 2.9m | 80in. 203.2cm | 64in. 162.6cm | 48in. 121.9cm |
| 9.8ft. 3.0m | 11.81ft. 3.6m | 100in. 254.0cm | 80in. 203.2cm | 60in. 152.4cm |
| 11.92ft. 3.6m | 14.4ft. 4.4m | 120in. 304.8cm | 96in. 243.8cm | 72in. 182.9cm |
| 15ft. 4.6m | 18ft. 5.5m | 150in. 381.0cm | 120in. 304.8cm | 90in. 228.6cm |
| 20ft. 6.1m | 24ft. 7.3m | 200in. 508.0cm | 160in. 406.4cm | 120in. 304.8cm |

Note: These sizes are ±10 percent. This is due to variations in the manufacture of the lens. If you are close to one of the endpoints you should verify with your unit that the image is the proper size at the proper distance.

Important Notice

All statements, technical information, and recommendations related to 3M's products are based on information believed to be reliable, but the accuracy or completeness is not guaranteed. Before using this product, you must evaluate it and determine if it is suitable for your intended application. You assume all risks and liability associated with such use. Any statements related to the product which are not contained in 3M's current publications, or any contrary statements contained on your purchase order shall have no force or effect unless expressly agreed upon, in writing, by an authorized officer of 3M.

Warranty; Limited Remedy; Limited Liability

This product will be free from defects in material and manufacture for a period of 3 years from the time of purchase. 3M MAKES NO OTHER WARRANTIES or CONDITIONS INCLUDING, BUT NOT LIMITED TO, ANY IMPLIED WARRANTY OR CONDITION OF MERCHANTABILITY OR FITNESS FOR A PARTICULAR PURPOSE. If this product is defective within the warranty period stated above, your exclusive remedy shall be, at 3M's option, to replace or repair the 3M product or refund the purchase price of the 3M product. Except where prohibited by law, 3M will not be liable for any indirect, special, incidental or consequential loss or damage arising from this 3M product, regardless of the legal theory asserted.

3M Visual Systems Division

Building A145-5N-01
6801 River Place Blvd.
Austin, TX 78726-9000

3M Mexico, S.A. de C.V.

Apartado Postal 14-139
Mexico, D.F. 07070
Mexico

3M Canada

P.O. Box 5757
London, Ontario, Canada
N6A 4T1

Litho in U.S.A. © 3M 2004

78-6970-8609-4

(11.04.15m)tg Rev. A

1-800-328-1371

www.3m.com/meetings

Hg—LAMP CONTAINS MERCURY. Manage in accord with disposal laws. See www.lamprecycle.org or call 1-800-328-1371 (USA), 1-800-364-3577 (Canada). For product disposal see www.eiae.org (USA) or www.epsc.ca (Canada).

Specifications subject to change without notice.

3M is a trademark of 3M Company. Used under license in Canada. All other trade names referenced are the service marks, trademarks, or registered trademarks of their respective companies. © Copyright Pininfarina 2004 - All rights reserved.

3M Innovation