

Panasonic

ideas for life

PT-LB20VU
Micro Portable XGA LCD Projector

1600lm XGA



**Daylight
View**

Presentations in Light



■ **Daylight View technology**

- Image performance rivaling 2,400-lumen projectors**
- Vivid colors in a bright room
- Auto operation with ambient light sensor

■ **Quick operation**

- 2-second speed start
- One-touch auto setup with digital keystone correction
- Direct power off

■ **Portability**

- Compact notebook-size body
- Ultra-lightweight: 4.6 lbs (2.1 kg)

*1 In comparison with our product

ProSelecta

View :: Compare :: Select - www.ProSelecta.com

Daylight View Technology



Daylight View

Many people want to use special colors and designs in their presentations, but these colors change when they're projected onto the screen in a lighted room. So they just use plain, basic colors.

As a result, the presentation is visually boring and looks just like their competitor's.

Panasonic solves this problem with our micro-portable projector featuring innovative Daylight View technology. The PT-LB20VU greatly improves image performance in brightly lit places. In fact, the 1,600-lumen brightness of the PT-LB20VU achieves a level of image performance that equals many 2,400-lumen projectors.*1*2

Image Performance Rivaling 2,400-Lumen Projectors

Daylight View technology significantly improves image performance. Our new 1,600-lumen projector has attained a level of image performance that equals or exceeds that of our previous 2,400-lumen models in brightly lit environments.*2

The Panasonic PT-LB20VU with Daylight View



Vivid colors in a Bright Room

Panasonic's unique Daylight View technology greatly improves color perception in bright rooms. Pale colors are divided into six basic color components (red, green, blue, yellow, cyan and magenta) for more precise control. Daylight View achieves a superb level of image performance that produces less of a difference between PC display images and projected images.

Auto Operation with Ambient Light Sensor

The top panel of the unit is equipped with an ambient light sensor (ALS). The ALS detects changes in the ambient light intensity and optimizes color compensation in four steps according to the environment. The Daylight View mode also provides white balance adjustment settings for both fluorescent and incandescent lamps to match the room lighting.

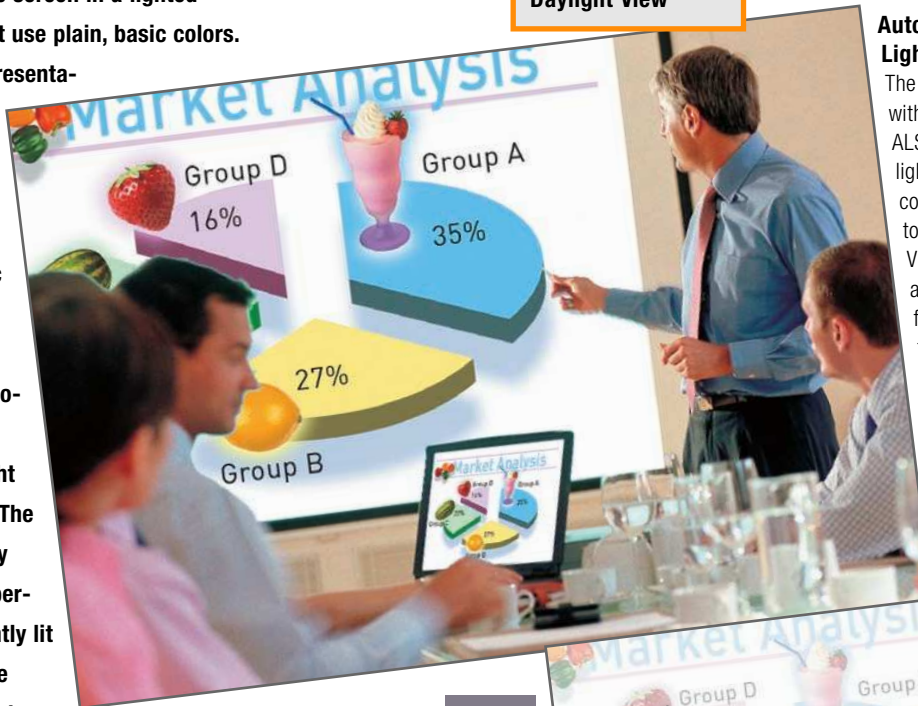

Conventional 1,600-lumen projectors

Colors turn whitish

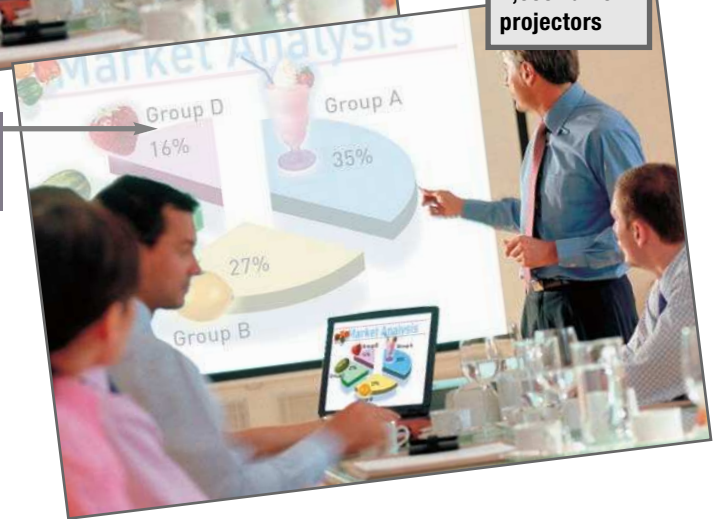

Daylight View technology enables Panasonic projectors to achieve the same image performance as projectors a class above them, while consuming less power. This helps to save energy resources that would otherwise be wasted.



The Daylight View Process

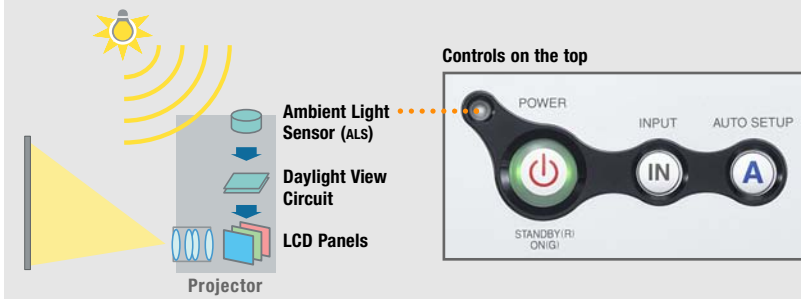

Quick Operation

2-Second Speed Start

Speed Start slashes the time it takes to get your presentation under way. The image appears within two seconds after you press the power button. Behind this breakthrough is Panasonic's high-precision lamp and lamp power supply—an advantage made possible by our advanced production technology.

One-Touch Auto Setup with Digital Keystone Correction

This function assures quick and easy setup. The projector handles the basic image adjustments, from phasing to vertical and horizontal position. The built-in gravity sensor detects the projector's angle relative to the floor and corrects for vertical keystone distortion accordingly.

Direct Power Off

When the presentation is completed, Direct Power Off lets you disconnect the power cable and move the projector right away*³ because the cooling fan keeps operating until the lamp is cooled.



Ecology-Conscious Design

Panasonic meticulously works to minimize environmental impact in the product design, production and delivery processes, and in the performance of the product itself over its life cycle. The PT-LB20VU reflects the following ecological considerations.

- Lead-free solder is used to mount components to the printed circuit boards.
- No halogenated flame retardants are used in the cabinet.
- No styrofoam is used in the packing materials.
- Lead-free glass is used for the lens.
- The packing case and operating manual are made from recycled paper.

Portability

Notebook-Size Compact Body

PT-LB20VU is 11-11/16" wide by 8-1/4" deep—about the size of a sheet of paper—and only



2-9/16" high. It slips easily into a bag or briefcase. The compact size makes the PT-LB20VU highly mobile and minimizes the space required for presentations or storage.

Ultra-Lightweight: 4.6 lbs (2.1 kg)

At only 4.6 lbs, PT-LB20VU won't weigh you down—even when you're toting along a notebook PC as well. Convenient size and weight are just two reasons why the PT-LB20VU is the logical choice for mobile presentations.

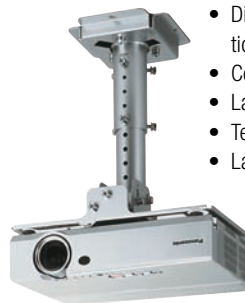

Optional ceiling mount bracket: ET-PKB30

More Valuable Features

- Short-throw zoom lens
- Anti-theft features: User password, control panel lock and text superimposing
- Projector AI
- Index Window
- Auto power off
- Two RGB inputs
- RGB 2 IN can be switched to RGB 1 OUT for loop-through monitoring
- Auto Search
- Automatic input signal detector
- HDTV compatibility
- Full compatibility with sRGB color space for accurate color reproduction (in natural mode)
- Picture mode selection (standard/dynamic/natural)
- Blackboard mode allows you to project images onto an ordinary classroom or conference room blackboard
- 3x digital zoom
- Freeze
- Shutter function for image/sound muting
- Selectable 17-language on-screen menu (English, French, German, Spanish, Italian, Korean, Russian, Chinese, Japanese, Swedish, Norwegian, Danish, Portuguese, Polish, Hungarian, Czech, Thai)
- Discrete S-Video and video inputs allow connection of two DVD/video sources at a time
- Ceiling mountable (option)
- Lamp power high/low selection
- Temperature warning indication
- Lamp replacement warning indication

*¹ In comparison with our product, under room lighting conditions of 400 lux, when projecting an 80-inch image (measured diagonally)

*² The Daylight View effect may vary depending on screen size, screen gain, and surrounding brightness.

*³ The projector cannot be placed into a bag until the cooling fan stops operating.





Specifications

Power supply	100–240 V AC, 50/60 Hz
Power consumption	220 W (Approx. 4 W in standby mode with fan stopped)
Amps	2.5 A–1.3 A
LCD panel	4:3 aspect ratio, micro lens array
Panel size	0.6" (15.24 mm) diagonal
Display method	Transparent LCD panel (x 3, R/G/B)
Drive method	Active matrix
Pixels	786,432 (1,024 x 768) x 3, total of 2,359,296 pixels
Pixel configuration	Stripe
Lens	Manual zoom (1:1–1:1.2), manual focus, F 1.7–1.9, f 21.5–25.8 mm
Lamp	155 W UHM™ lamp
Colors	Full color (16,777,216 colors)
Brightness	1,600 lumens
Uniformity	90%
Contrast	400:1*1 (full on/full off)
Scanning frequency	
RGB	Horizontal: 15–91 kHz, Vertical: 50–85 Hz
YPbPr	480i (525i): fh 15.75 kHz; fv 60 Hz 576i (625i): fh 15.63 kHz; fv 50 Hz 480p (525p): fh 31.5 kHz; fv 60 Hz 576p (625p): fh 31.25 kHz; fv 50 Hz 720p (750p): fh 45 kHz; fv 60 Hz 1080i (1125i): fh 33.75 kHz; fv 60 Hz 1080i (1125i): fh 28.125 kHz; fv 50 Hz
S-Video/Video	NTSC, NTSC4.43, PAL-M, PAL60: fh 15.75 kHz; fv 60 Hz PAL, SECAM, PAL-N: fh 15.63 kHz; fv 50 Hz
Projection size	838–7,620 mm/33–300 inches diagonally
Throw distance	4'7"–41'8" (1.4 m–12.7 m)
Optical axis shift	12:1 (fixed)
Keystone correction range	Vertical: approx. ±30°
On-screen menu	17 languages: English, French, German, Spanish, Italian, Korean, Russian, Chinese, Japanese, Swedish, Norwegian, Danish, Portuguese, Polish, Hungarian, Czech, Thai
Installation	Front/rear ceiling/desk (menu selection)
Built-in speakers	1.0 W (monaural) output power
Terminals	
RGB1 IN	D-sub HD 15-pin x 1
RGB signal	R, G, B: 0.7 Vp-p, 75 ohms, Sync on green: 1.0 Vp-p, 75 ohms HD/SYNC, VD: TTL (positive/negative polarity compatible)

YPbPr signal	Y: 1.0 Vp-p (including sync signal), 75 ohms; Pb, Pr: 0.7 Vp-p, 75 ohms
RGB2 IN/RGB1 OUT	D-sub HD 15-pin x 1 (input/output selectable using on-screen menu)
RGB signal	R, G, B: 0.7 Vp-p, 75 ohms, Sync on green: 1.0 Vp-p, 75 ohms HD/SYNC, VD: TTL (positive/negative polarity compatible)
YPbPr signal	Y: 1.0 Vp-p (including sync signal), 75 ohms; Pb, Pr: 0.7 Vp-p, 75 ohms
VIDEO IN	RCA pin x 1, 1.0 Vp-p, 75 ohms
S-VIDEO IN	Mini DIN 4-pin x 1, Y: 1.0 Vp-p, C: 0.286 Vp-p, 75 ohms
AUDIO IN	RCA (L, R) x 1, 0.5 Vrms (for RGB/VIDEO/ S-VIDEO)
SERIAL	Mini DIN 8-pin x 1 (RS-232C)
Power cord length	6'7" (2 m)
Cabinet material	Molded material (ABS/PC)
Dimensions (W x H x D)	11-11/16" x 2-9/16" x 8-1/4" (297 x 65 x 210 mm)*2
Weight	4.6 lbs. (2.1 kg)
Operating environment	
Temperature	32°–104°F (0°–40°C)
Humidity	20%–80% (no condensation)
Remote Control Unit	
Power supply	3 V DC (button battery x 1)
Operation range*3	Approx. 7 m (23 feet) when operated from directly in front of the signal receptor
Dimensions (W x H x D)	1-9/16" x 3-3/8" x 1/4" (40 x 86 x 6.5 mm)
Weight	0.6 oz. (18 g) (including a battery)

Supplied Accessories

- Card remote control
- Lithium battery for remote control
- Power cord
- RGB signal cable
- Carrying bag

Optional Accessories

ET-LAB10	Replacement lamp unit
ET-PKB30	Ceiling mount bracket
ET-RM300	Full-function wireless remote control
ET-ADSER	Serial adapter (DIN 8-pin/D-sub 9-pin)

*1: In AI mode.

*2: Height including protruding parts and legs: 2-27/32" (73 mm).

*3: Operation range differs depending on the environment.

Dimensions

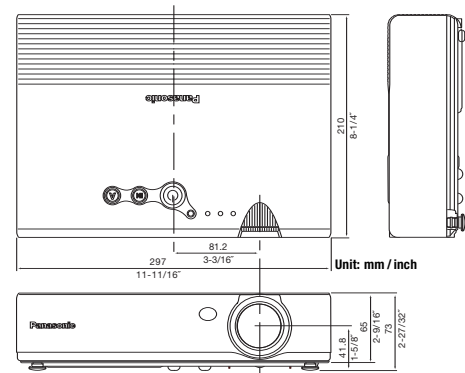

Projection Distance

Diagonal image size (4:3 aspect ratio)	Distance to screen		Height from the edge of screen to center of lens
	min.	max.	
33" / 0.84 m / 2.7'	–	1.4 m / 4.6'	4 cm / 1.6"
40" / 1.02 m / 3.3'	1.4 m / 4.6'	1.7 m / 5.6'	5 cm / 2.0"
50" / 1.27 m / 4.2'	1.7 m / 5.6'	2.1 m / 6.9'	6 cm / 2.4"
60" / 1.52 m / 4.9'	2.1 m / 6.9'	2.5 m / 8.2'	7 cm / 2.8"
70" / 1.78 m / 5.8'	2.4 m / 7.9'	2.9 m / 9.5'	8 cm / 3.1"
80" / 2.03 m / 6.7'	2.8 m / 9.2'	3.4 m / 11.2'	9 cm / 3.5"
90" / 2.29 m / 7.5'	3.1 m / 10.2'	3.8 m / 12.5'	11 cm / 4.3"
100" / 2.54 m / 8.3'	3.5 m / 11.5'	4.2 m / 13.8'	12 cm / 4.7"
120" / 3.05 m / 10.0'	4.2 m / 13.8'	5.0 m / 16.4'	14 cm / 5.5"
150" / 3.81 m / 12.5'	5.2 m / 17.0'	6.3 m / 20.7'	18 cm / 7.1"
200" / 5.08 m / 16.7'	7.0 m / 22.9'	8.4 m / 27.6'	23 cm / 9.1"
250" / 6.35 m / 20.8'	8.7 m / 28.5'	10.6 m / 34.8'	29 cm / 11.4"
300" / 7.62 m / 25.0'	10.5 m / 34.4'	12.7 m / 41.7'	35 cm / 13.8"

NOTES ON USE

- The projector uses a high-voltage mercury lamp that contains high internal pressure. This lamp may break, emitting a large sound, or fail to illuminate, due to impact or extended use. The length of time that it takes for the lamp to break or fail to illuminate varies greatly depending on individual lamp characteristics and usage conditions.
- The brightness of the lamp will gradually decrease with use.
- The lamp, LCD panel, polarizing plate, and polarizing beam splitter (PBS) are consumable parts. These parts may need to be replaced during the guarantee period if the projector is used for six or more hours per day.
- The replacement cycle of the LCD panel, polarizing plate, and polarizing beam splitter (PBS) will be shortened if the projector is subjected to continuous use for six or more hours. Likewise, the replacement cycle of the lamp will be shortened if the power is frequently turned on and off or the projector is subjected to continuous use for 10 or more hours.

Panasonic®

Panasonic Broadcast & Television Systems Company
Presentation Systems Group
1 888 843 9788
www.panasonic.com/projectors

Headquarters
1 Panasonic Way, 4E-7
Secaucus, NJ 07094
201 348 5300

Panasonic Canada Inc.
5770 Ambler Drive
Mississauga, Ontario
Canada L4W 2T3
905 624 5010

Please contact Panasonic or your dealer for a demonstration.



Weights and dimensions shown are approximate. Specifications are subject to change without notice. This product may be subject to export control regulations. UHM is a trademark of Matsushita Electric Industrial Co., Ltd. VGA and XGA are trademarks of International Business Machines Corporation. Windows and PowerPoint are either registered trademarks or trademarks of Microsoft Corporation in the United States and/or other countries. All other trademarks are the property of their respective trademark owners. Projection images simulated.
PT-LB20VU1-05MAR12K Printed in Japan.