

Data Projector

Operating Instructions

GB

VPL-PX11

WARNING

To prevent fire or shock hazard, do not expose the unit to rain or moisture.

To avoid electrical shock, do not open the cabinet. Refer servicing to qualified personnel only.

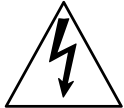

This symbol is intended to alert the user to the presence of uninsulated “dangerous voltage” within the product’s enclosure that may be of sufficient magnitude to constitute a risk of electric shock to persons.



This symbol is intended to alert the user to the presence of important operating and maintenance (servicing) instructions in the literature accompanying the appliance.

For the customers in the USA

This equipment has been tested and found to comply with the limits for a Class A digital device, pursuant to Part 15 of the FCC Rules. These limits are designed to provide reasonable protection against harmful interference when the equipment is operated in a commercial environment. This equipment generates, uses, and can radiate radio frequency energy and, if not installed and used in accordance with the instruction manual, may cause harmful interference to radio communications. Operation of this equipment in a residential area is likely to cause harmful interference in which case the user will be required to correct the interference at his own expense.

You are cautioned that any changes or modifications not expressly approved in this manual could void your authority to operate this equipment.

Note

If the Remote Commander malfunctions or causes a malfunction, consult with qualified Sony personnel. We will exchange the Remote Commander for a new one based on the terms of the guarantee.

For the customers in Canada

This Class A digital apparatus complies with Canadian ICES-003.

For the customers in the United Kingdom

WARNING

THIS APPARATUS MUST BE EARTHED

IMPORTANT

The wires in this mains lead are coloured in accordance with the following code:

Green-and-Yellow: Earth
Blue: Neutral
Brown: Live

As the colours of the wires in the mains lead of this apparatus may not correspond with the coloured markings identifying the terminals in your plug proceed as follows:

The wire which is coloured green-and-yellow must be connected to the terminal in the plug which is marked by the letter E or by the safety earth symbol \perp or coloured green or green-and-yellow.

The wire which is coloured blue must be connected to the terminal which is marked with the letter N or coloured black.

The wire which is coloured brown must be connected to the terminal which is marked with the letter L or coloured red.

Voor de klanten in Nederland



- Dit apparaat bevat een vast ingebouwde batterij die niet vervangen hoeft te worden tijdens de levensduur van het apparaat.
- Raadpleeg uw leverancier indien de batterij toch vervangen moet worden. De batterij mag alleen vervangen worden door vakbekwaam servicepersoneel.
- Gooi de batterij niet weg maar lever deze in als klein chemisch afval (KCA).
- Lever het apparaat aan het einde van de levensduur in voor recycling, de batterij zal dan op correcte wijze verwerkt worden.

The socket-outlet should be installed near the equipment and be easily accessible.

Apparaten ma kun tilkoples jordet stikkontakt.
Apparatet må kun tilkoples jordet stikkontakt.

Warning on power connection

Use a proper power cord for your local power supply.

	The United States, Canada		Continental Europe		UK, Ireland, Australia, New Zealand	Japan
Plug type	VM0233	290B	YP-12A	COX-07	— ¹⁾	YP332
Female end	VM0089	386A	YC-13B	COX-02	VM0310B	YC-13
Cord type	SJT	SJT	H05VV-F	H05VV-F	N13237/CO-228	VCTF
Rated Voltage & Current	10A/125V	10A/125V	10A/250V	10A/250V	10A/250V	7A/125V
Safety approval	UL/CSA	UL/CSA	VDE	VDE	VDE	DENANHOU

1) Use the correct plug for your country.

Table of Contents

Overview

Precautions	7 (GB)
Features	8 (GB)
Location and Function of Controls	9 (GB)
Front / Left Side	9 (GB)
Rear / Right Side / Bottom	9 (GB)
Control Panel	11 (GB)
Connector Panel	12 (GB)
Remote Commander	13 (GB)

Setting Up and Projecting

Installing the Projector	15 (GB)
Connecting the Projector	15 (GB)
Connecting to a Computer	15 (GB)
Connecting to a VCR, 15k RGB/Component Equipment, or a Monitor	17 (GB)
Selecting the Menu Language	18 (GB)
Projecting	19 (GB)

Adjustments and Settings Using the Menu

Using the Menu	22 (GB)
The PICTURE CTRL Menu	23 (GB)
The INPUT SETTING Menu	24 (GB)
The SET SETTING Menu	26 (GB)
The INSTALL SETTING Menu	27 (GB)

Installation

Installation Example	29 (GB)
Notes for Installation	30 (GB)
Unsuitable Installation	30 (GB)
Unsuitable Conditions for Use	30 (GB)

Maintenance

Maintenance	32 (GB)
Replacing the Lamp	32 (GB)
Cleaning the Air Filter	33 (GB)
Troubleshooting	34 (GB)

Other

Specifications	36 (GB)
Index	39 (GB)

Precautions

On safety

- Check that the operating voltage of your unit is identical with the voltage of your local power supply.
- Should any liquid or solid object fall into the cabinet, unplug the unit and have it checked by qualified personnel before operating it further.
- Unplug the unit from the wall outlet if it is not to be used for several days.
- To disconnect the cord, pull it out by the plug. Never pull the cord itself.
- The wall outlet should be near the unit and easily accessible.
- The unit is not disconnected to the AC power source (mains) as long as it is connected to the wall outlet, even if the unit itself has been turned off.
- Do not look into the lens while the lamp is on.
- Do not place your hand or objects near the ventilation holes — the air coming out is hot.
- Be careful not to catch your fingers with the adjusters when you lift up the projector. Do not push hard on the top of the projector with the adjusters out.
- Be sure to grasp both sides when carrying the projector.

On illumination

- To obtain the best picture, the front of the screen should not be exposed to direct lighting or sunlight.
- Ceiling-mounted spot lighting is recommended. Use a cover over fluorescent lamps to avoid lowering the contrast ratio.
- Cover any windows that face the screen with opaque draperies.
- It is desirable to install the projector in a room where floor and walls are not of light-reflecting material. If the floor and walls are of reflecting material, it is recommended that the carpet and wall paper be changed to a dark color.

On preventing internal heat build-up

After you turn off the power with the I / ⏻ key on the Remote Commander or on the control panel, do not disconnect the unit from the wall outlet while the cooling fan is still running.

Caution

The projector is equipped with ventilation holes (intake) on the bottom and ventilation holes (exhaust) on the front. Do not block or place anything near these holes, or internal heat build-up may occur, causing picture degradation or damage to the projector.

On cleaning

- To keep the cabinet looking new, periodically clean it with a soft cloth. Stubborn stains may be removed with a cloth lightly dampened with a mild detergent solution. Never use strong solvents, such as thinner, benzene, or abrasive cleansers, since these will damage the cabinet.
- Avoid touching the lens. To remove dust on the lens, use a soft dry cloth. Do not use a damp cloth, detergent solution, or thinner.
- Clean the filter at regular intervals, every 300 hours.

On repacking

Save the original shipping carton and packing material; they will come in handy if you ever have to ship your unit. For maximum protection, repack your unit as it was originally packed at the factory.

About the LCD projector

The LCD projector is manufactured using high-precision technology. You may, however, see tiny black points and/or bright points (red, blue, or green) that continuously appear on the LCD projector. This is a normal result of the manufacturing process and does not indicate a malfunction.

Features

High brightness, high picture quality

- **High brightness**

The 200 W UHP lamp optical system provides brightness levels of as much as 2000 ANSI lumens and excellent picture uniformity.

- **High resolution**

Three 0.9-inch, approximately 790,000 pixel, XGA panels provide a resolution of 1024 × 768 dots for RGB input and 750 horizontal TV lines for video input.

Simple setup

- **Simple setup with external equipment**

The projector has 37 preset data items for input signals in memory, which allows you to project a clear picture on the screen simply by connecting equipment and pressing the APA (Auto Pixel Alignment) key.

- **USB application**

You can control the projector using the wireless mouse control function of the supplied Remote Commander. You can also control the projector from a computer operated with Microsoft¹⁾ Windows¹⁾ 98, Windows 98 SE, Windows 2000 or Windows XP using the “Projector Station” application software (CD-ROM) supplied with the projector.

Easy presentation

- **Multi functional Remote Commander with mouse control functions**

You can carry out the mouse functions of a computer connected to this projector using the Remote Commander because the unit has a built-in receiver for handling mouse commands.

- **Digital zoom / freeze functions**

This projector has a digital zoom function that enables you to enlarge the image at a desired location on the screen. The freeze function allows you to freeze the picture projected. The frozen picture continues to be projected even if the equipment is disconnected from the video source.

Accepts various input signals

- **Scan converter loaded**

This projector has a built-in scan converter that converts the input signal to 1024 × 768 dots.

- **Compatible input signals**

This projector accepts composite, S video, and component video signals as well as 15k RGB, VGA²⁾, SVGA²⁾, XGA²⁾, and SXGA²⁾ signals, which can all be displayed.

- **Compatible with six color systems**

Any of the NTSC^{3,58}, PAL, SECAM, NTSC^{4,43³⁾}, PAL-M, or PAL-N color systems can be selected automatically or manually.

Off & Go function (function of running the cooling fan while carrying the projector)

Built-in circuits keep the cooling fan running automatically for a certain period of time even though you have unplugged the power cord (Off & Go function). This function allows you to carry the projector to another location just after using the projector.

1) Microsoft and Windows are registered trademarks of Microsoft Corporation (U.S.A. and other countries).

2) VGA, SVGA, XGA and SXGA are registered trademarks of the International Business Machines Corporation, U.S.A.

3) NTSC^{4,43} is the color system used when playing back a video recorded on NTSC on an NTSC^{4,43} system VCR.

Location and Function of Controls

Front / Left Side

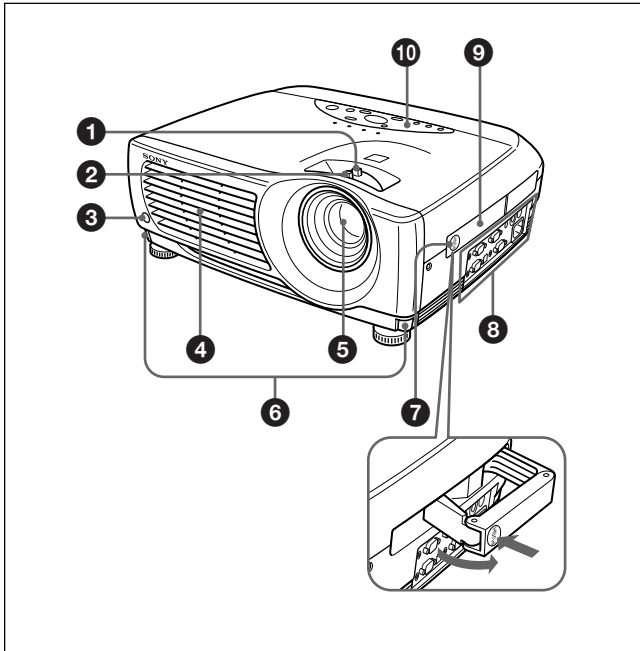

❶ Zoom ring

Adjusts the size of the picture.

❷ Focus ring

Adjusts the picture focus.

❸ Front remote control detector

❹ Ventilation holes (exhaust)

❺ Lens

Remove the lens cap before projection.

❻ Adjuster buttons

❼ Handle release

Push to make the carrying handle ❹ pop up.

❽ Connector panel

For details, see "Connector Panel" on page 12 (GB).

❾ Carrying handle

Use the handle release ❼ to make the handle pop up from the projector for carrying.

❿ Control panel

For details, see "Control Panel" on page 11 (GB).

Rear / Right Side / Bottom

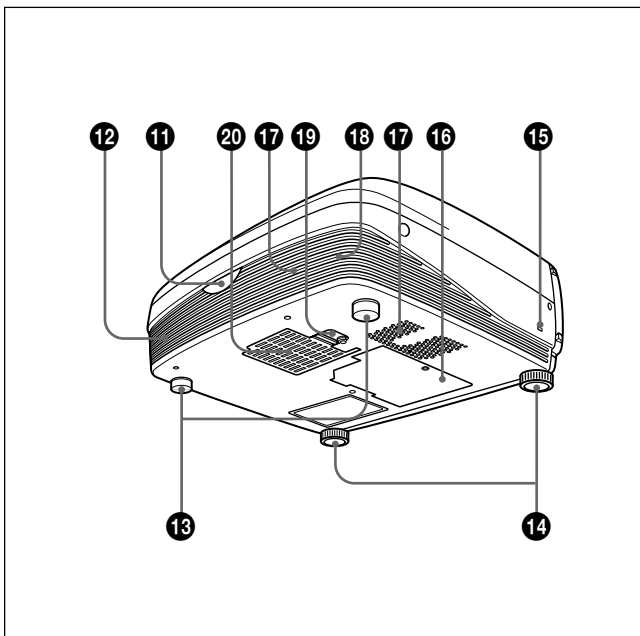

❶ Rear remote control detector

❷ Left speaker

❸ Rear adjusters

❹ Adjusters

When a picture is projected on an exterior of the screen, adjust the picture using these adjusters.

For details on how to use the adjusters, see "How to use the adjusters" on page 10 (GB).

❺ Security lock

Connects to an optional security cable (made by Kensington)¹⁾.

Home page address:

<http://www.kensington.com/>

1) Kensington is registered trademark of Kensington Technology Group.

16 Lamp cover

17 Ventilation holes (intake)

18 Right speaker

19 Air filter cover lock

Used to remove the air filter cover.

For details, see “Cleaning the Air Filter” on page 33 (GB).

Note

Clean the air filter every 300 hours to ensure optimal performance.

20 Ventilation holes (intake) / air filter cover

Notes

- Do not place anything near the ventilation holes as it may cause internal heat build-up.
- Do not place your hand or objects near the ventilation holes — the air coming out is hot.

How to use the adjusters

To adjust the height

Adjust the height of the projector as follows:

- 1** Lift the projector and press the adjuster buttons. The adjusters will extend from the projector.

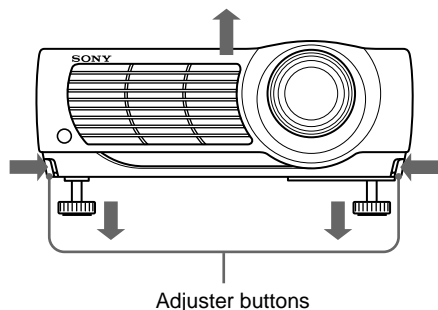

- 2** While pressing the buttons, adjust the height. Then, release the buttons. The adjusters will lock, then the height of the projector will be fixed. For fine adjustment, turn the adjusters to the right or left.

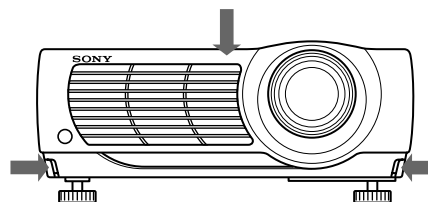

Note

If the adjusters have been extended to the limit and you keep turning the adjusters counterclockwise, the adjusters will stop turning and the adjuster buttons cannot be pressed. In this case, turn the adjusters clockwise, and then press the adjuster buttons again.

- 3** If necessary, turn the rear adjusters to the right or left to adjust the height of the projector.

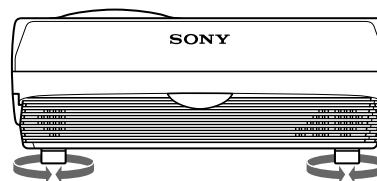

Notes

- Be careful not to let the projector down on your fingers.
- Do not push hard on the top of the projector with the adjusters out.

Control Panel

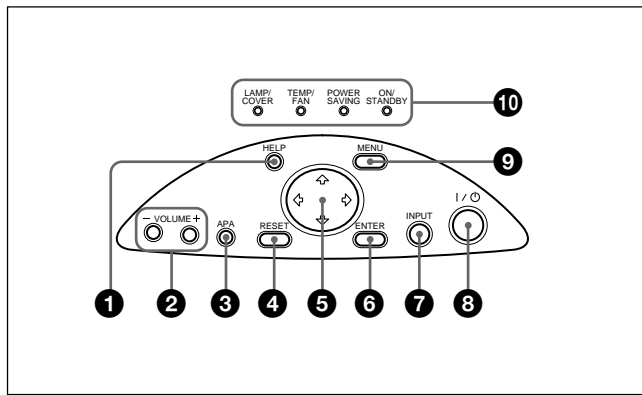

1 HELP key

If you need help information during an operation, press this key to display help messages. The Help menu lists error recovery techniques depending on problem type.

2 VOLUME +/- keys

Adjust the volume of the built-in speakers.

- + : Increases the volume.
- : Decreases the volume.

3 APA (Auto Pixel Alignment) key

Adjusts the picture to be projected automatically to give the clearest picture possible while a signal from the computer is input. Adjusts the shift (up/down and left/right) at the same time automatically.

Note

Press the APA key when the full image is displayed on the screen. If there are black edges around the image, the APA function will not function properly and the image may extend beyond the screen.

4 RESET key

Resets the value of an item to its factory preset value. This key functions when the menu or a setting item is displayed on the screen.

5 Arrow (↑/↓/←/→) keys

Used to select a menu or to make various adjustments.

6 ENTER key

Enters the settings of items in the menu system.

7 INPUT key

Selects the input signal. Each time you press the key, the input signal switches as follows:

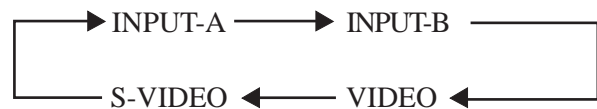

Note

The audio signals are the same for the VIDEO and S-VIDEO.

8 I / ⏻ (on / standby) key

Turns the projector on and off when the projector is in the standby mode. The ON/STANDBY indicator lights in green when the power is turned on.

When turning off the power, press the I / ⏻ key twice following the message on the screen, or press and hold the key for about one second.

For details on steps for turning off the power, see "To turn off the power" on page 20 (GB).

9 MENU key

Displays the on-screen menu. Press again to clear the menu.

10 Indicators

LAMP/COVER: Lights up or flashes under the following conditions:

- Lights up when the lamp has reached the end of its life or has reached a high temperature.
- Flashes when the lamp cover or air filter cover is not secured firmly.

TEMP (Temperature)/FAN: Lights up or flashes under the following conditions:

- Lights up when temperature inside the projector becomes unusually high.
- Flashes when the fan is broken.

POWER SAVING: Lights up when the projector is in the power saving mode. When POWER SAVING in the SET SETTING menu is set to ON, the projector goes into the power saving mode if no signal is input for 10 minutes. Although the lamp goes out, the cooling fan keeps running. The power saving mode is canceled when a signal is input or any key is pressed. However, in the power saving mode, none of the keys function for the first 60 seconds.

ON/STANDBY: Lights up or flashes under the following conditions:

- Lights up in red when the AC power cord is plugged into the wall outlet. Once in the standby mode, you can turn on the projector with the I / ⏻ key.

Note

The built-in circuits provided for carrying out the Off & Go function (page 8 (GB)) may keep the cooling fan running for a while after the ON/STANDBY indicator turns from green to red just after you turn off the projector by pressing the I / ⏻ key.

- Lights up in green when the power is turned on.
- Flashes in green while the cooling fan runs after the power is turned off with the I / ⏻ key. The fan runs for about 90 seconds after turning off the power.

The ON/STANDBY indicator flashes quickly for the first 60 seconds of that time.

During this first 60 seconds, you cannot turn the power back on with the I / ⏻ key.

For details on the LAMP/COVER and the TEMP/FAN indicators, see page 35 (GB).

Connector Panel

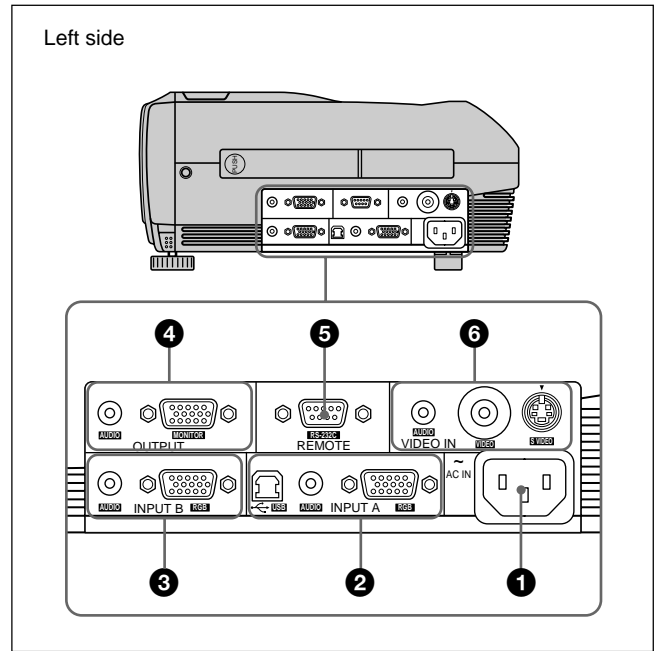

1 AC IN socket

Connects the supplied AC power cord.

2 INPUT A connectors

Connect to external equipment such as a computer.

RGB connector (HD D-sub 15-pin, female):

Connects to the monitor output on a computer using the supplied cable.

When inputting a component or 15k RGB signal, use the appropriate cable.

For details, see “To connect 15k RGB/Component equipment” on page 17 (GB).

AUDIO jack (stereo minijack): Connects to the audio output of the computer.

USB connector (USB B-plug for upstream, 4-pin):

Connects to a computer. When you connect the projector to the computer via this connector, the projector recognizes that a USB mouse is connected and you can control the mouse function of the computer connected to the INPUT A connector using the supplied Remote Commander. The supplied application software can be used on the computer connected to this connector.

③ INPUT B connectors

Connects to a computer.

RGB connector (HD D-sub 15-pin, female):

Connects to the monitor output connector of a computer using the supplied cable. This connector accepts monitor output signals only from a computer.

AUDIO jack (stereo minijack): Connects to the audio output connector of the computer.

④ OUTPUT connectors

Connects to external equipment such as a monitor.

MONITOR connector (HD D-sub 15-pin, female):

Connects to the video input connector of external equipment such as a monitor. Outputs currently selected signals from the INPUT A/B connector.

AUDIO jack (stereo minijack): Connects to the audio input connector of external equipment. When connected to an active speaker, you can control the volume of the speaker using the VOLUME +/- keys on the control panel.

⑤ REMOTE (RS-232C) connector (D-sub 9-pin, female)

Connects to a computer to operate the projector from the computer.

⑥ VIDEO IN (Video input) connectors

Connect to external video equipment such as a VCR.

S VIDEO connector (mini DIN 4-pin): Connects to the S video output (Y/C video output) of video equipment.

VIDEO jack (phono type): Connects to the composite video output of video equipment.

AUDIO jack (stereo minijack): Connects to the audio output of the VCR.

Remote Commander

Keys which have the same names as those on the control panel function identically.

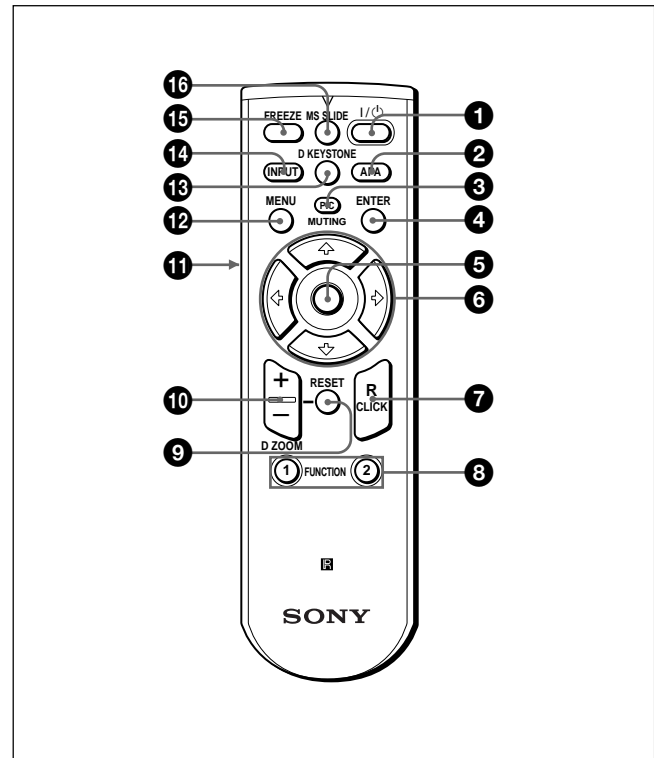

① I / ⏻ (on / standby) key

② APA (Auto Pixel Alignment) key

③ PIC (Picture) MUTING key

Cuts off the picture. Press again to restore the picture.

④ ENTER key

⑤ Joystick

Functions as the mouse of the computer connected to this projector.

⑥ Arrow (↑/↓/←/→) keys

⑦ R (right) CLICK key

Functions as the right button of a mouse.

8 FUNCTION 1, 2 keys

Functions when the supplied application software is used. When you connect the projector with a computer, you can open a file on the screen by just pressing a FUNCTION key. This will enhance your presentation. To use this function, allocate a file to the FUNCTION key by using the application software.

For details, see the README file and HELP file supplied with the application software.

9 RESET key

Resets the value of an item to its factory preset value or returns the enlarged image back to its original size.

10 D ZOOM +/- key

Enlarges the image at a desired location on the screen. This key works only when a signal from a computer is input.

+: Pressing the + key once displays the icon. This icon indicates the point you want to enlarge. Use an arrow key (↑/↓/←/→) to move the icon to the point to be enlarged. Press the + key repeatedly until the image is enlarged to meet your requirements.

-: Each press of the - key reduces an image that has been enlarged with the D ZOOM + key.

11 L (left) CLICK key

Functions as the left button of a mouse.

12 MENU key**13 D KEYSTONE key**

Corrects the trapezoidal distortion caused by the projection angle. Use the arrow keys (↑/↓/←/→) to display the image as a rectangle.

14 INPUT key**15 FREEZE key**

Used to freeze the picture projected. To cancel the frozen picture, press the key again.

16 MS SLIDE key

This key does not operate with this unit.

Battery installation

- 1 Push and slide to open the lid, then install the two R6 (size AA) batteries (supplied) with the correct polarity.

Slide while pressing down on the lid.

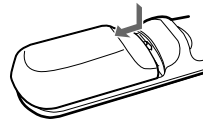

Be sure to install the battery from the ⊖ side.

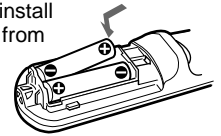

- 2 Replace the lid.

Notes on batteries

- Make sure that the battery orientation is correct when inserting batteries.
- Do not mix an old battery with a new one, or different types of batteries.
- If you do not intend to use the Remote Commander for a long time, remove the batteries to avoid damage from battery leakage. If batteries have leaked, remove them, wipe the battery compartment dry and replace the batteries with new ones.

Notes on Remote Commander operation

- Make sure that there is nothing to obstruct the infrared beam between the Remote Commander and the remote control detector on the projector. Direct the Remote Commander toward the front or rear remote control detector.
- The operation range is limited. The shorter the distance between the Remote Commander and the projector is, the wider the angle within which the commander can control the projector.

Installing the Projector

This section describes how to install the projector.

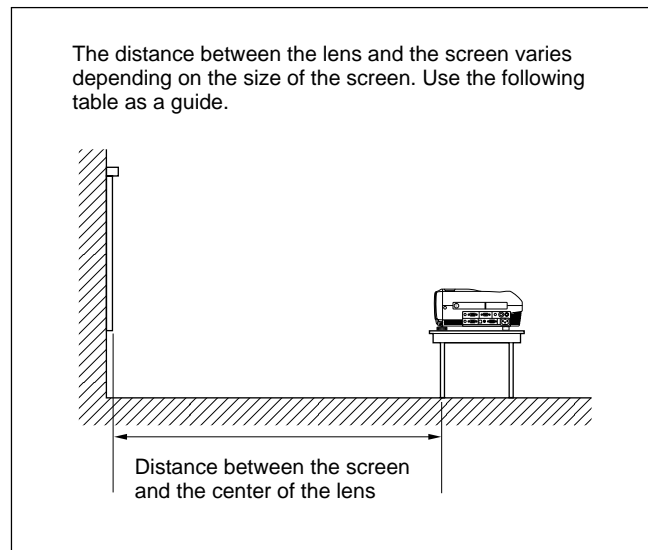

Unit: m (feet)

Screen size (inches)	40	60	80	100	120	150	180	200	250	300
Minimum Distance	1.5 (4.8)	2.2 (7.3)	3.0 (9.8)	3.7 (12.3)	4.5 (14.8)	5.6 (18.5)	6.8 (22.3)	7.5 (24.8)	9.4 (31.0)	11.3 (37.3)
Maximum Distance	1.8 (5.8)	2.7 (8.8)	3.6 (11.8)	4.5 (14.8)	5.4 (17.8)	6.8 (22.2)	8.1 (26.7)	9.1 (29.7)	11.3 (37.2)	13.6 (44.7)

For details, see "Installation Example" on page 29 (GB).
For details on ceiling installation, consult with qualified Sony personnel (fee charged).

Connecting the Projector

When making connections, be sure to do the following:

- Turn off all equipment before making any connections.
- Use the proper cables for each connection.
- Insert the cable plugs properly; plugs that are not fully inserted often generate noise or cause picture degradation. When pulling out a cable, be sure to pull it out grasping the plug, not the cable itself.

Connecting to a Computer

This section describes how to connect the projector to a computer.

For more information, refer to the computer's instruction manual.

Notes

- The projector accepts VGA, SVGA, XGA, and SXGA signals. However, we recommend that you set the output mode of your computer to XGA mode for the external monitor.
- If you set your computer, such as a notebook type, to output the signal to both your computer's display and an external monitor, the picture of the external monitor may not appear properly. Set your computer to output the signal to only the external monitor. For details, refer to the operating instructions supplied with your computer.
- This projector is compatible with DDC2B (Display Data Channel 2B). If your computer is compatible with DDC¹⁾, turn the projector on according to the following procedures.

- 1 Connect the projector to the computer using the supplied HD D-sub 15-pin cable.
- 2 Turn the projector on.
- 3 Start the computer.

1) DDC™ is a registered trademark of the Video Electronics Standards Association.

To connect an IBM¹⁾ PC/AT¹⁾ compatible computer

When you use a USB mouse

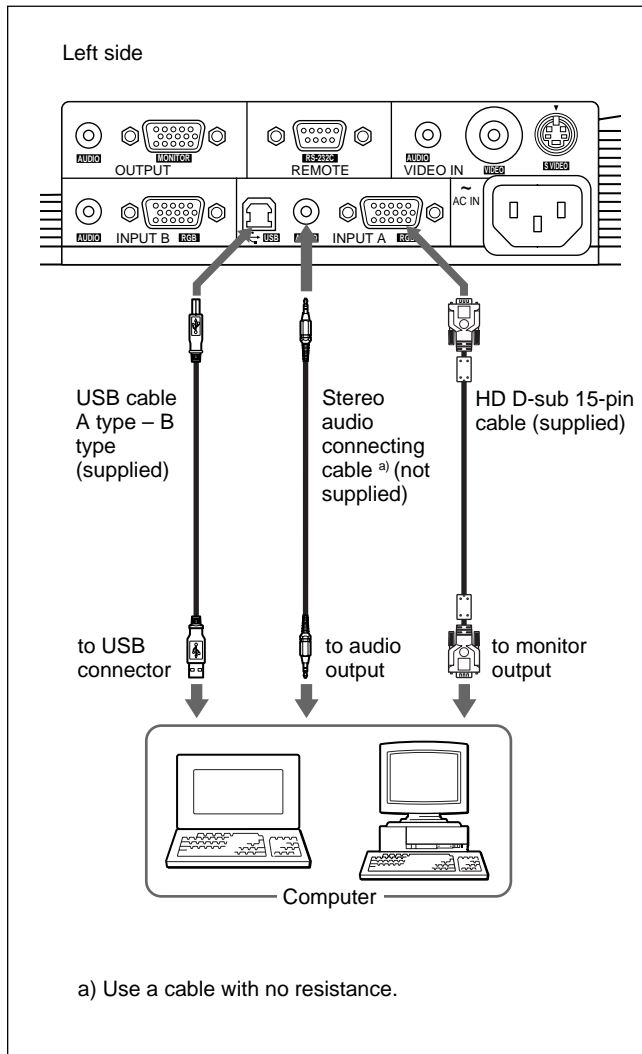

On the USB function

When connecting the projector to a computer using the USB cable for the first time, the computer recognizes the following devices automatically.

- 1 USB hub (general use)
- 2 USB human interface device (wireless mouse function)
- 3 USB human interface device (projector control function)

Recommended operating environment

When you use the USB function, connect your computer as illustrated in the box on the left. This application software and the USB function can be used on a computer loaded with Windows 98, Windows 98 SE, Windows 2000 or Windows XP.

Notes

- The projector recognizes the USB mouse when the computer is connected to the USB connector.
- Your computer may not start correctly when connected to the projector via the USB cable. In this case, disconnect the USB cable, restart the computer, then connect the computer to the projector using the USB cable.
- This projector is not guaranteed for suspend or standby mode. When you use the projector in suspend or standby mode, disconnect the projector from the USB port on the computer.
- Operations are not guaranteed for all the recommended computer environments.

To connect a Macintosh²⁾ computer

When connecting a video output connector that has a two-line pin configuration, use the appropriate adaptor for that type of connector (not supplied). If your Macintosh supports a USB function, you can use the wireless mouse function by connecting a USB cable.

1) IBM® and PC/AT are a trademark and a registered trademark of International Business Machines Corporation, U.S.A.
 2) Macintosh is a registered trademark of Apple Computer, Inc.

Connecting to a VCR, 15k RGB/ Component Equipment, or a Monitor

This section describes how to connect the projector to a VCR, to 15k RGB/component equipment, or to a monitor.

For more information, refer to the instruction manuals of the equipment you are connecting.

To connect a VCR

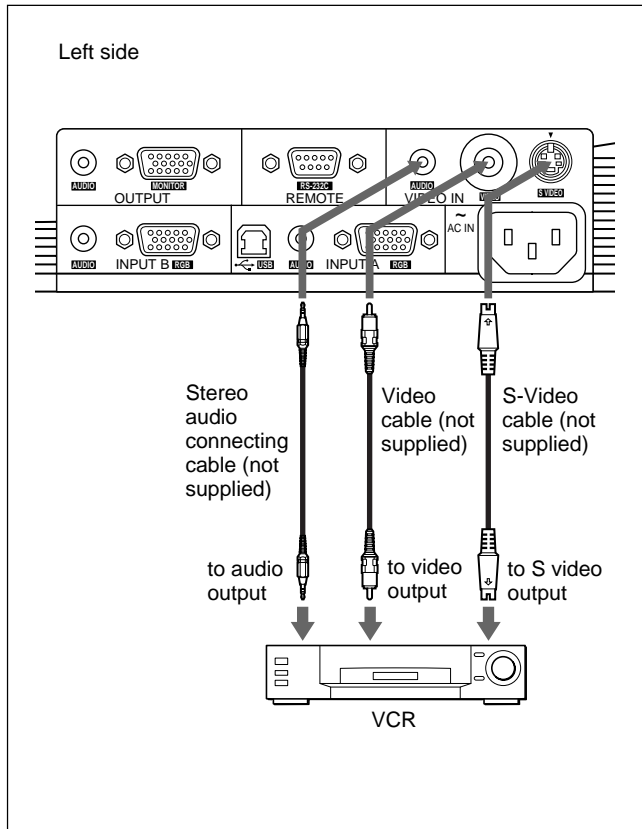

To connect 15k RGB/Component equipment

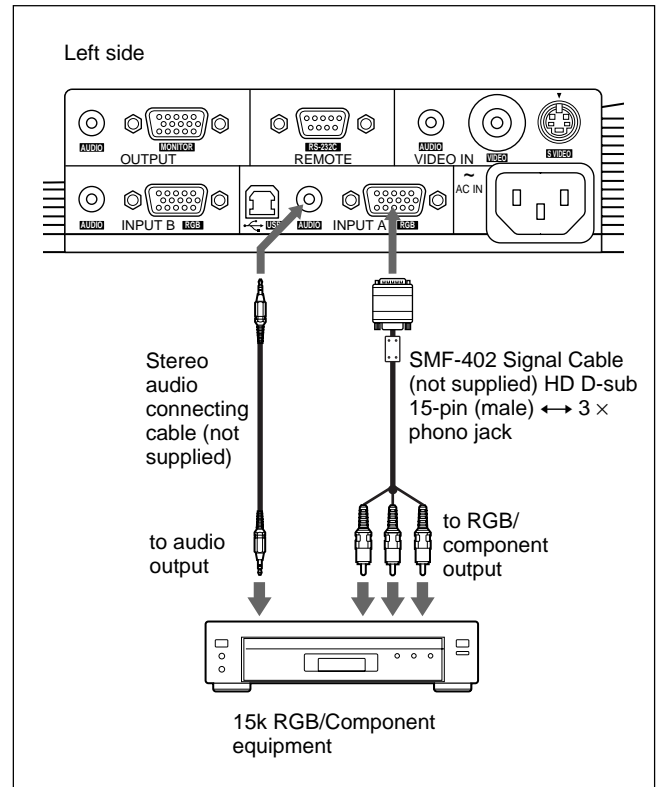

Notes

- Connect 15k RGB/component equipment to the INPUT A connectors. You cannot connect this type of equipment to the INPUT B connectors.
- Set the aspect ratio using ASPECT in the INPUT SETTING menu according to the input signal.
For details, see page 25 (GB).
- When you connect the projector to 15k RGB/component video equipment, select RGB, component or VCR GBR as the INPUT-A setting in the SET SETTING menu.
- Use the composite sync signal when you input the external sync signal from 15k RGB/component equipment.

To connect a monitor

When you want to display the projected image on an external monitor at the same time

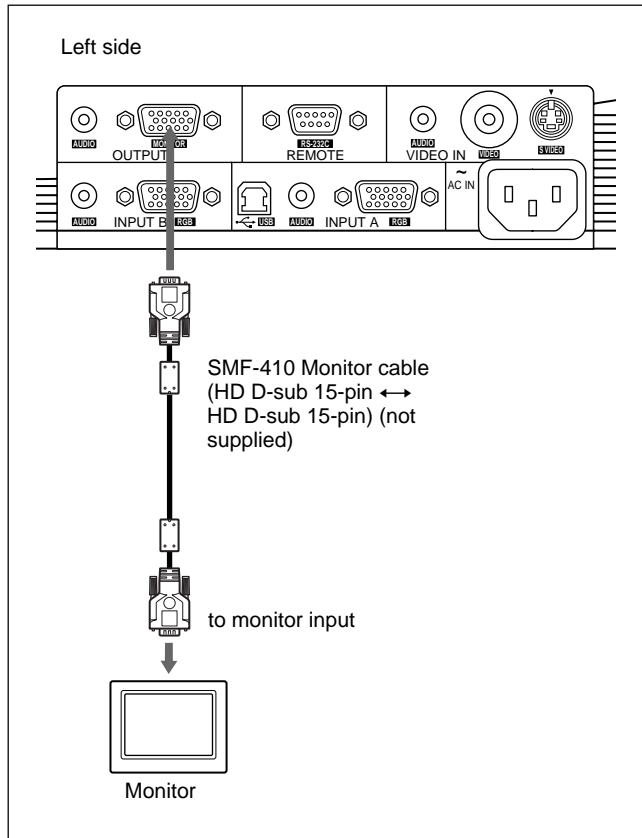

Selecting the Menu Language

You can select the language to be used in the menu and other on screen displays from 9 languages. The factory setting is ENGLISH.

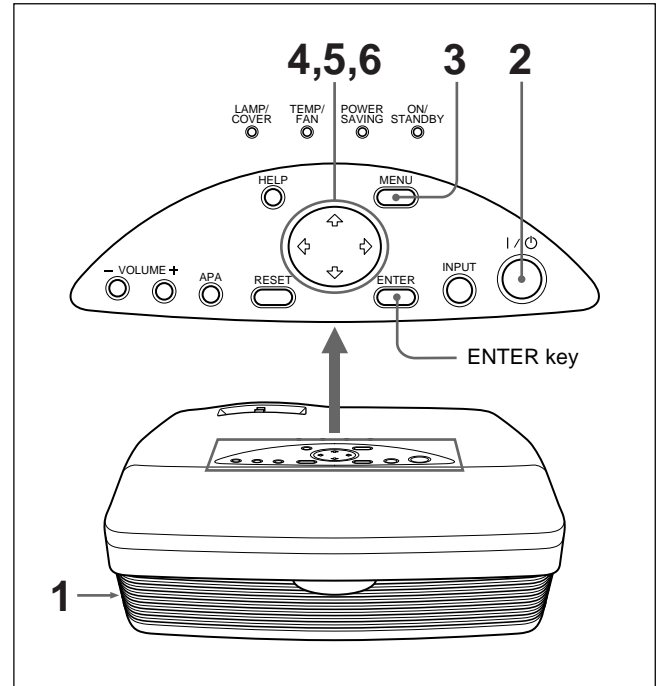

- 1 Plug the AC power cord into the wall outlet.
- 2 Press the I / ⏻ key to turn on the power.
- 3 Press the MENU key.
The menu display appears.
- 4 Press the ↑ or ↓ key to select the SET SETTING menu, then press the → or ENTER key.
The SET SETTING menu appears.

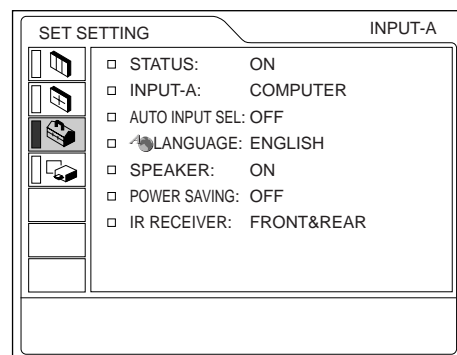

- 5 Press the **↑** or **↓** key to select LANGUAGE, then press the **→** or ENTER key.
- 6 Press the **↑** or **↓** key to select a language, then press the **←** or ENTER key.
The menu changes to the selected language.

To clear the menu display

Press the MENU key.
The menu display disappears automatically if no key is pressed for one minute.

Projecting

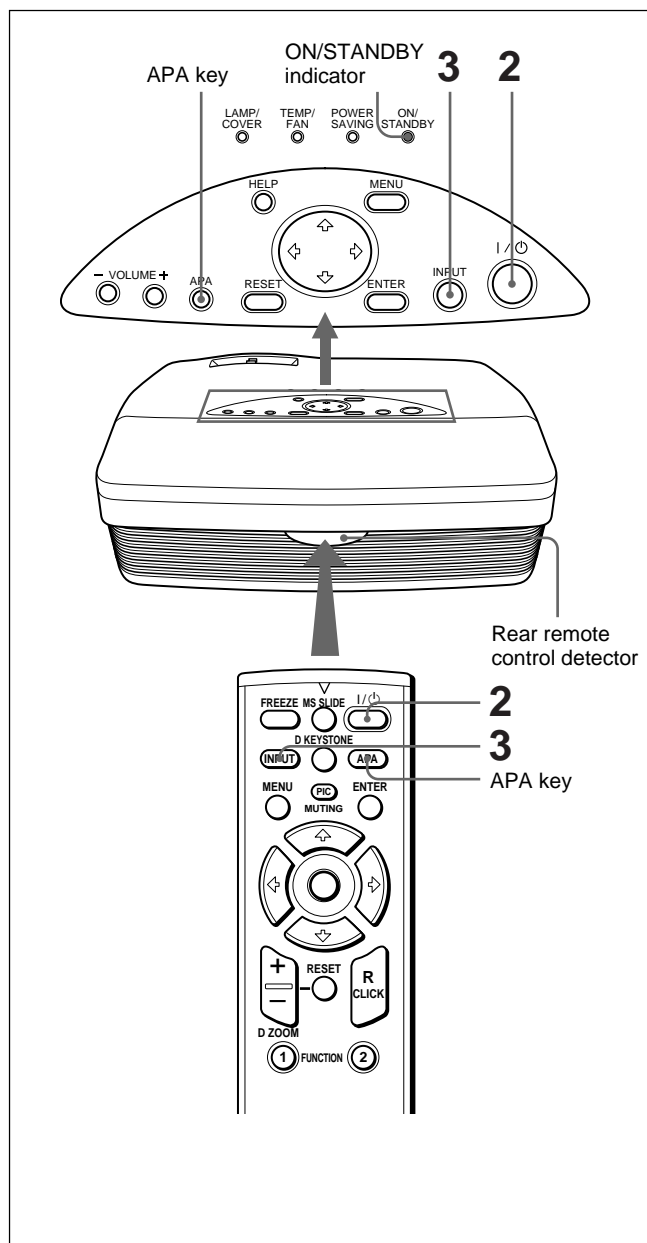

- 1 After all equipment is connected completely, plug the AC power cord into the wall outlet.
The ON/STANDBY indicator lights in red and the projector goes into the standby mode.
- 2 Press the I / **⏻** key to turn on the projector.
The ON/STANDBY indicator lights in green.
- 3 Turn on all equipment connected to the projector.
Press the INPUT key to select the input source.
 - INPUT-A:** Selects the video signal input from the INPUT A connector.
 - INPUT-B:** Selects the video signal input from a computer connected to the INPUT B connector.
 - VIDEO:** Selects the video signal input from a VCR connected to the VIDEO jack on the VIDEO IN connectors.
 - S-VIDEO:** Selects the video signal input from a VCR connected to the S VIDEO connector on the VIDEO IN connectors.

Depending on the type of computer you have, for example a notebook, or an all-in-one LCD type, you may have to switch the computer to output to the projector by pressing a certain combination of keys (e.g., **LCD/VGA**, etc.), or by changing your computer's settings.

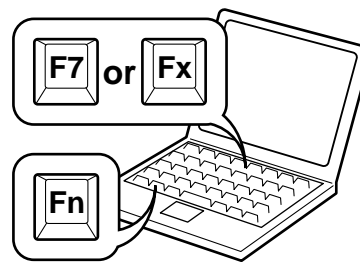

- 4 Turn the zoom ring to adjust the size of the picture.
- 5 Turn the focus ring to adjust the focus.

Note

Looking into the lens when the projector is projecting an image may cause injury to your eyes.

To cut off the picture

Press the PIC MUTING key on the Remote Commander. To restore the picture, press the PIC MUTING key again.

To get the clearest picture

You can get the best picture automatically when a signal from the computer is input. Press the APA key. The picture is automatically adjusted to project the clearest picture possible.

Notes

- Adjust the signal when a still picture is displayed on the screen.
- Press the APA key when the full image is displayed on the screen. If there are black edges around the image, the APA function will not function properly and the image may extend beyond the screen.
- If you switch the input signal or re-connect a computer, press the APA key again to get the suitable picture.
- “ADJUSTING” appears on the screen. To restore the original screen, press the APA key again during the adjustment.
- “Complete!” appears on the screen when the picture is adjusted properly. However, depending on the kinds of input signal, the picture may not always be adjusted properly.
- Adjust the items in the INPUT SETTING menu when you adjust the picture manually.
For details on the INPUT SETTING menu, see page 24 (GB).

To correct trapezoidal distortion

When the projected image is a trapezoid, correct it by pressing the D KEYSTONE key on the Remote Commander or by adjusting DIGIT KEYSTONE in the INSTALL SETTING menu.

When the base edge is longer than the upper edge as shown in the figure below:

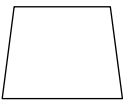

Set the value to negative.

When the upper edge is longer than the base edge as shown in the figure below:



Set the value to positive.

For details on “DIGIT KEYSTONE,” see page 28 (GB).

To turn off the power

- 1 Press the I / ⏻ key.
“Power OFF?” appears on the screen.

Note

The message will disappear if you press any key except the I / ⏻ key, or if you do not press any key for five seconds.

- 2 Press the I / ⏻ key again.
The ON/STANDBY indicator flashes in green and the fan continues to run for about 90 seconds to reduce internal heat build-up. Also, the ON/STANDBY indicator flashes quickly for the first 60 seconds. During this first 60 seconds, you will not be able to turn the power back on with the I / ⏻ key.

- 3 Unplug the AC power cord from the wall outlet after the ON/STANDBY indicator lights in red.

Note

The built-in circuits provided for carrying out the Off & Go function (page 8 (GB)) may keep the cooling fan running for a while after the ON/STANDBY indicator turns from green to red just after you turn off the projector by pressing the I / ⏻ key.

When you cannot confirm the on-screen message

When you cannot confirm the on-screen message at anytime, you can turn off the power by holding the I / ⏻ key for about one second.

When you want to turn off the projector quickly

You can also disconnect the power cord without pressing I / ⏻ key. The cooling fan keeps running automatically due to built-in circuits for a certain period of time even though you unplug the power cord (Off & Go function).

However, if the projector has not been turned on for a long enough time, the cooling fan may not turn since the projector’s condenser has not sufficiently charged.

If you do not use the Off & Go function

Unplug the AC power cord according to the procedure described in “To turn off the power.”

Cleaning the air filter

Clean the air filter every 300 hours to ensure optimal performance.

To enlarge the image (Digital Zoom function)

You can enlarge an area on the image you select. This function works only when a signal from a computer is input.

- 1 Project the original size picture and press the D ZOOM + key on the Remote Commander. The Digital Zoom icon appears in the center of the image.

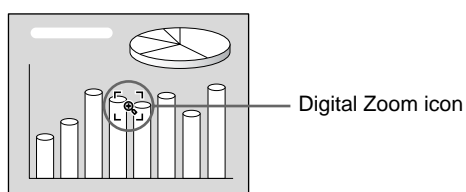

- 2 Move the icon to a point in the center of the portion of the image you want to enlarge. Use the arrow keys (↑/↓/←/→) to move the icon.

- 3 Press the D ZOOM + key again. The portion of the image where the icon is located is enlarged. The magnification ratio is displayed on the screen for a few seconds. By pressing the + key repeatedly, the image size increases (maximum magnification: 4 times) .

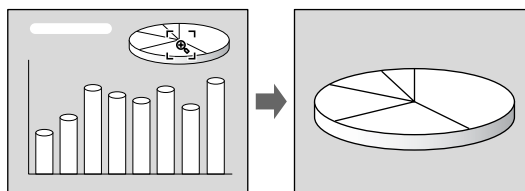

Use the arrow keys (↑/↓/←/→) to scroll the enlarged image.

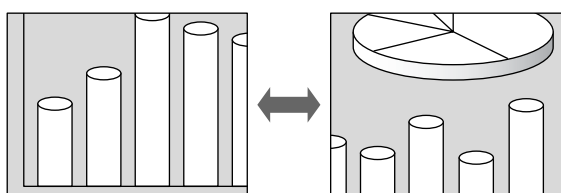

To return the image to its original size

Press the D ZOOM – key. Pressing the RESET key returns the image to its original size in one operation.

To freeze the image projected (Freeze function)

Press the FREEZE key. “FREEZE” appears when the key is pressed. This function works only when a signal from a computer is input.

To restore the original screen, press the FREEZE key again.

Using the Menu

The projector is equipped with an on-screen menu for making various adjustments and settings.

To select the language used in the menu, see page 18 (GB).

- 1 Press the MENU key.
The menu display appears.
The menu presently selected is shown as a yellow button.

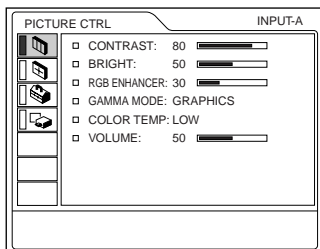

- 2 Use the ↑ or ↓ key to select a menu, then press the → or ENTER key.
The selected menu appears.

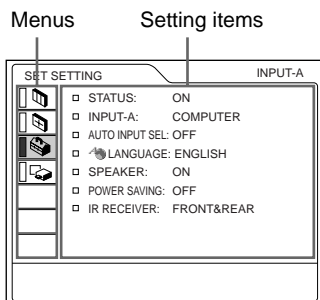

- 3 Select an item.
Use the ↑ or ↓ key to select the item, then press the → or ENTER key.
- 4 Make settings or adjustments on an item.
For details on setting individual items, see the relevant menu pages.

To clear the menu

Press the MENU key.
The menu display disappears automatically if no key is pressed for one minute.

To reset items that have been adjusted

Press the RESET key.
“Complete!” appears on the screen and the settings appearing on the screen will be reset to their factory preset values.

Items that can be reset are:

- “CONTRAST,” “BRIGHT,” “COLOR,” “HUE,” “SHARP,” and “RGB ENHANCER” in the PICTURE CTRL menu.
- “DOT PHASE,” “SIZE H,” and “SHIFT” in the INPUT SETTING menu.
- “DIGIT KEYSTONE” in the INSTALL SETTING menu.

About the retention of the settings

The settings are automatically stored in the projector memory.

When no signal is input

When there is no input signal, “NO INPUT–Cannot adjust this item.” appears on the screen, and the items mentioned above cannot be adjusted.

About the menu display

You can set the display position of the menu, the intensity of the background picture, and the color of the menu items as you like.

For details, see page 28 (GB).

The PICTURE CTRL Menu

The PICTURE CTRL (control) menu is used for adjusting the picture.

Unadjustable items for a particular input signal are not displayed in the menu.

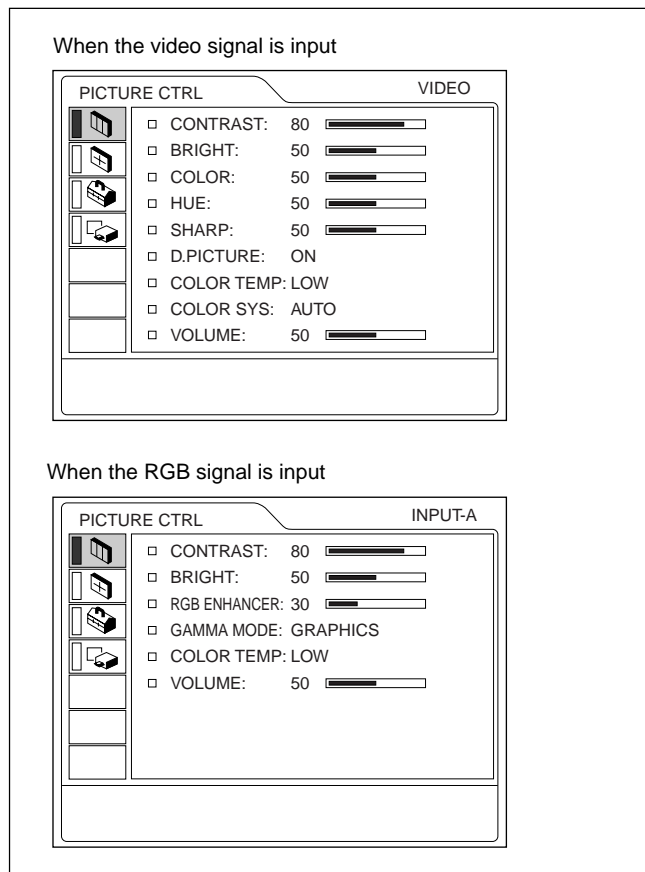

Operation

1. Select an item

Use the **↑** or **↓** key to select the item, then press the **→** or **ENTER** key.

2. Adjust an item

- When changing the adjustment level:
 - To increase the value, press the **↑** or **→** key.
 - To decrease the value, press the **↓** or **←** key.
 - Press the **ENTER** key to restore the original screen.
- When changing the setting:
 - Press the **↑** or **↓** key to change the setting.
 - Press the **ENTER** or **←** key to restore the original screen.

CONTRAST

Adjusts the picture contrast.

The higher the setting, the greater the contrast.

The lower the setting, the lower the contrast.

BRIGHT

Adjusts the picture brightness.

The higher the setting, the brighter the picture.

The lower the setting, the darker the picture.

COLOR

Adjusts color intensity.

The higher the setting, the greater the intensity.

The lower the setting, the lower the intensity.

HUE

Adjusts color tones.

The higher the setting, the more the picture becomes greenish.

The lower the setting, the more the picture becomes purplish.

SHARP

Adjusts the picture sharpness.

The higher the setting, the sharper the picture.

The lower the setting, the softer the picture.

RGB ENHANCER

Adjusts the picture sharpness when RGB signals are input.

The higher the setting, the sharper the picture.

The lower the setting, the softer the picture.

D. (Dynamic) PICTURE

Emphasizes the black color.

ON: Emphasizes the black color to produce a bolder “dynamic” picture.

OFF: Reproduces the dark portions of the picture accurately, in accordance with the source signal.

GAMMA MODE

Selects a gamma correction curve.

GRAPHICS: Improves the reproduction of half tones. Photos can be reproduced in natural tones.

TEXT: Contrasts black and white. Suitable for images that contain lots of text.

COLOR TEMP

Adjusts the color temperature.

HIGH: Makes the white color bluish.

LOW: Makes the white color reddish.

COLOR SYS (System)

Selects the color system of the input signal.

AUTO: Automatically selects one of the following signals: NTSC_{3.58}, PAL, SECAM, NTSC_{4.43}.

PAL-M/N: Automatically selects one of the following signals: PAL-M/PAL-N, NTSC_{3.58}.

Normally, set to AUTO.

If the picture is distorted or colorless, select the color system appropriate to the input signal.

VOLUME

Adjusts the volume. The volume can be adjusted for each of INPUT A, INPUT B, VIDEO and S VIDEO input.

Input signals and adjustable/setting items

Item	Input signal			
	Video or S video (Y/C)	Component	Video GBR	RGB ¹⁾
CONTRAST	●	●	●	●
BRIGHT	●	●	●	●
COLOR	● (except for B & W)	●	●	—
HUE	● (NTSC _{3.58} / 4.43 only)	●	●	—
SHARP	●	●	●	—
RGB ENHANCER	—	—	—	●
D. PICTURE	●	●	—	—
GAMMA MODE	—	—	—	●
COLOR TEMP	●	●	●	●
COLOR SYS	●	—	—	—
VOLUME	●	●	●	●

● : Adjustable/can be set

— : Not adjustable/can not be set

1) The RGB signals of a computer

The INPUT SETTING Menu

The INPUT SETTING menu is used to adjust the input signal.

Unadjustable items for a particular input signal are not displayed in the menu.

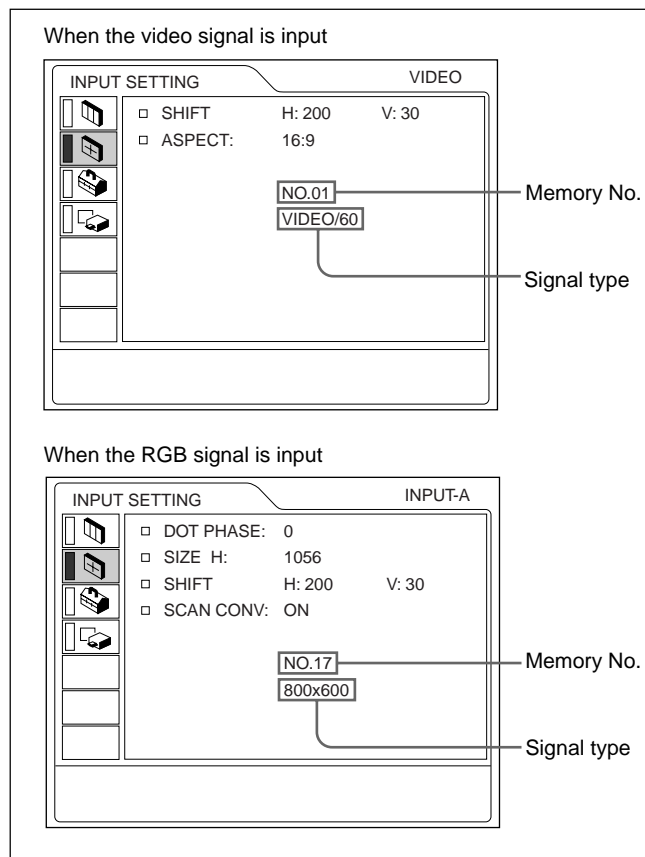

Operation

1. Select an item

Use the **↑** or **↓** key to select the item, then press the **→** or **ENTER** key.

2. Adjust an item

- When changing the adjustment level:
To increase the value, press the **↑** or **→** key.
To decrease the value, press the **↓** or **←** key.
Press the **ENTER** key to restore the original screen.
- When changing the setting:
Press the **↑** or **↓** key to change the setting.
Press the **ENTER** or **←** key to restore the original screen.

DOT PHASE

Adjusts the dot phase of the LCD panel and the signal input from the INPUT A/B connector. Adjust the picture further for a finer picture after the picture is adjusted by pressing the APA key. Adjust the picture to the point where it looks clearest.

SIZE H

Adjusts the horizontal size of the picture input from the INPUT A/B connector.

The higher the setting, the larger the horizontal size of the picture.

The lower the setting, the smaller the horizontal size of the picture. Adjust the setting according to the dots of the input signal.

For details on a suitable value for preset signals, see page 26 (GB).

SHIFT

Adjusts the position of the picture input through the INPUT A/B connectors or VIDEO IN connectors.

H adjusts the horizontal position of the picture.

V adjusts the vertical position of the picture.

As the setting for H increases, the picture moves to the right, and as the setting decreases, the picture moves to the left.

As the setting for V increases, the picture moves up, and as the setting decreases, the picture moves down.

Use the ← or → key to adjust the horizontal position and the ↑ or ↓ key for the vertical position.

ASPECT

Sets the aspect ratio of the picture.

When inputting a 16:9 (squeezed) signal from equipment such as a DVD player, set this to 16:9.

4:3 : When a picture with a ratio of 4:3 is input.

16:9 : When a picture with a ratio of 16:9 (squeezed) is input.

SCAN CONV (Scan converter)

Converts the signal to display the picture according to the screen size.

ON: Displays the picture according to the screen size. The picture will lose some clarity.

OFF: Displays the picture while matching one pixel of the input picture element to that of the LCD.

The picture will be clear but the picture size will be smaller.

Note

This item will not be displayed if you input an XGA or SXGA signal.

Input signals and adjustable/setting items

Item	Input signal			
	Video or S video (Y/C)	Component	Video GBR	RGB ¹⁾
DOT PHASE	–	–	–	●
SIZE H	–	–	–	●
SHIFT	●	●	●	●
ASPECT	●	●	●	–
SCAN CONV	–	–	–	● ²⁾

● : Adjustable/can be set

– : Not adjustable/can not be set

1) The RGB signals of a computer

2) Lower than SVGA only

About the preset memory No.

This projector has 37 kinds of preset data for input signals (the preset memory). The memory number of the current input signal and the signal type are displayed when the preset signal is input. This projector automatically detects the signal type. When the signal has been registered in the preset memory, a suitable picture is displayed on the screen according to the signal type. You can adjust the picture through the INPUT SETTING menu.

This projector also has 20 kinds of user memories for each INPUT A/B. When an unpreset signal is input for the first time, the memory number is displayed as 0. If the input signal is adjusted in the INPUT SETTING menu, the setting made via INPUT A/B is stored. When more than 20 user memory items are registered for each INPUT A/B, the newest memory item is automatically stored over the oldest one.

Preset signals

Memory No.	Preset signal	fH (kHz)	fV (Hz)	Sync	SIZE H	
1	Video 60 Hz	15.734	59.940	H-neg V-neg		
2	Video 50 Hz	15.625	50.000	H-neg V-neg		
3	480/60i	15.734	59.940	S on G/Y or		
4	575/50i	15.625	50.000	Composite sync		
6	640 × 350	VGA mode 1	31.469	70.086	H-pos V-neg	800
7		VGA VESA ¹⁾ 85 Hz	37.861	85.080	H-pos V-neg	832
8	640 × 400	PC-9801 ²⁾ Normal	24.823	56.416	H-neg V-neg	848
9		VGA mode 2	31.469	70.086	H-neg V-pos	800
10		VGA VESA 85 Hz	37.861	85.080	H-neg V-pos	832
11	640 × 480	VGA mode 3	31.469	59.940	H-neg V-neg	800
12		Macintosh 13"	35.000	66.667	H-neg V-neg	864
13		VGA VESA 72 Hz	37.861	72.809	H-neg V-neg	832
14		VGA VESA 75 Hz	37.500	75.000	H-neg V-neg	840
15		VGA VESA 85 Hz	43.269	85.008	H-neg V-neg	832
16	800 × 600	SVGA VESA 56 Hz	35.156	56.250	H-pos V-pos	1024
17		SVGA VESA 60 Hz	37.879	60.317	H-pos V-pos	1056
18		SVGA VESA 72 Hz	48.077	72.188	H-pos V-pos	1040
19		SVGA VESA 75 Hz	46.875	75.000	H-pos V-pos	1056
20		SVGA VESA 85 Hz	53.674	85.061	H-pos V-pos	1048
21	832 × 624	Macintosh 16"	49.724	74.550	H-neg V-neg	1152
22	1024 × 768	XGA VESA 43 Hz	35.524	86.958 ³⁾	H-pos V-pos	1264
23		XGA VESA 60 Hz	48.363	60.004	H-neg V-neg	1344
24		XGA VESA 70 Hz	56.476	69.955	H-neg V-neg	1328
25		XGA VESA 75 Hz	60.023	75.029	H-pos V-pos	1312
26		XGA VESA 85 Hz	68.677	84.997	H-pos V-pos	1376
27		1152 × 864	SXGA VESA 70 Hz	63.995	70.016	H-pos V-pos
28	SXGA VESA 75 Hz		67.500	75.000	H-pos V-pos	1600
29	SXGA VESA 85 Hz		77.487	85.057	H-pos V-pos	1568
30	1152 × 900	Sunmicro LO	61.795	65.960	H-neg V-neg	1504
31		Sunmicro HI	71.713	76.047	Composite sync	1472
32	1280 × 960	SXGA VESA 60 Hz	60.000	60.000	H-pos V-pos	1800
33		SXGA VESA 75 Hz	75.000	75.000	H-pos V-pos	1728
34	1280 × 1024	SXGA VESA 43 Hz	46.433	86.872 ³⁾	H-pos V-pos	1696
35		SGI-5	53.316	50.062	S on G	1680
36		SXGA VESA 60 Hz	63.974	60.013	H-pos V-pos	1696
37		SXGA VESA 75 Hz	79.976	75.025	H-pos V-pos	1688
38		SXGA VESA 85 Hz	91.146	85.024	H-pos V-pos	1530

- 1) VESA is a registered trademark of the Video Electronics Standards Association.
- 2) PC-98 is a registered trademark of NEC Corporation.
- 3) The data preset in memory numbers 22 and 34 are the interlace signals.
- 4) Set the resolution and the frequency of the signal of a computer connected to the projector within the limits of the preset signal values.

Since the data is recalled from the preset memory for the following signals, you can use this preset data by adjusting SIZE H. Make finer adjustments using SHIFT.

Signal	Memory No.	SIZE H
Super Mac-2	23	1312
SGI-1	23	1320
Macintosh 19"	25	1328
Macintosh 21"	27	1456
Sony News	36	1708
PC-9821 1280 × 1024	36	1600
WS Sunmicro	37	1664

Note

When the aspect ratio of an input signal is other than 4:3, a part of the screen is displayed in black.

The SET SETTING Menu

The SET SETTING menu is used for changing the settings of the projector.

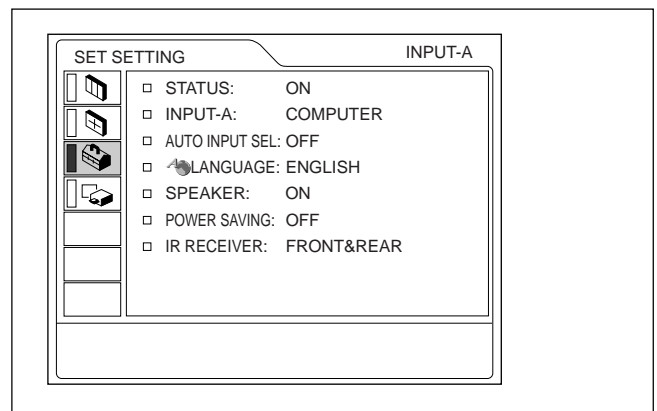

Operation

1. Select an item

Use the **↑** or **↓** key to select the item, then press the **→** or ENTER key.

2. Change the setting

Press the **↑** or **↓** key to change the setting.

To restore the original screen, press the ENTER or **←** key.

STATUS (on-screen display)

Sets up the on-screen display.

ON: Shows all of the on-screen display.

OFF: Turns off the on-screen display except for the menus, a message when turning off the power, and warning messages.

For details on the warning messages, see page 35 (GB).

INPUT-A

Selects the computer, component or video GBR (15k RGB) signal input from the INPUT A connector.

Note

If the setting is not correct, “Please check INPUT-A setting.” appears on the screen and the color of the picture becomes strange or the picture is not displayed.

AUTO INPUT SEL

When set to ON, the projector detects input signals in the following order: INPUT-A/INPUT-B/VIDEO/S-VIDEO. It indicates the input channel when the power is turned on or the INPUT key is pressed.

LANGUAGE

Selects the language used in the menu and on-screen displays.

Available languages are: English, French, German, Italian, Spanish, Japanese, Chinese, Portuguese and Korean.

SPEAKER

Set to OFF to cut off the sound of the internal speakers. When set to OFF, “SPEAKER OFF” appears on the screen when you turn on the power.

POWER SAVING

When set to ON, the projector goes into the power saving mode if no signal is input for 10 minutes.

IR RECEIVER

Selects the remote control detectors on the front and rear of the projector.

FRONT & REAR: Activates both the front and rear detectors.

FRONT: Activates the front detector only.

REAR: Activates the rear detector only.

The INSTALL SETTING Menu

The INSTALL SETTING menu is used for changing the install settings of the projector.

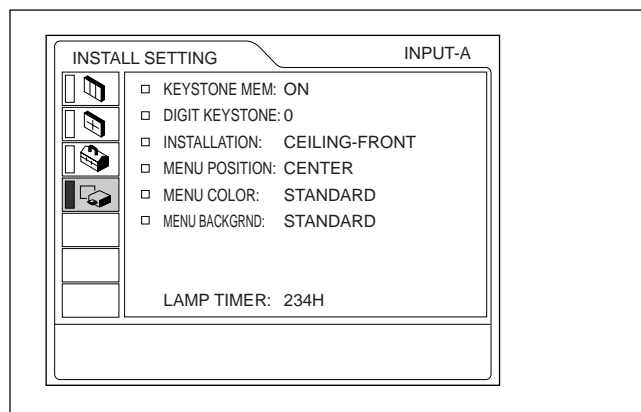

Operation

1. Select an item

Use the **↑** or **↓** key to select the item, then press the **→** or ENTER key.

2. Adjust an item

- When changing the adjustment level:
 - To increase the value, press the **↑** or **→** key.
 - To decrease the value, press the **↓** or **←** key.
 - Press the ENTER key to restore the original screen.
- When changing the setting:
 - Press the **↑** or **↓** key to change the setting.
 - Press the ENTER or **←** key to restore the original screen.

KEYSTONE MEM

- ON:** The DIGIT KEYSTONE setting is stored.
The data is retrieved when the projector power is turned on. The setting will remain the same every time.
- OFF:** The DIGIT KEYSTONE is reset to 0 when the power is turned on next time.

DIGIT KEYSTONE

Corrects the trapezoidal distortion caused by the projection angle.
If the base edge of the image is longer, set a negative value; if the upper edge is longer, set a positive value to display the image as a rectangle.

INSTALLATION

Set this item to reverse the picture horizontally or vertically.

- FLOOR-FRONT:** The picture is not reversed.
CEILING-FRONT: The picture is reversed horizontally and vertically.
FLOOR-REAR: The picture is reversed horizontally.
CEILING-REAR: The picture is reversed vertically.

Note

When using a mirror, be careful of how the installation is carried out since the picture may be reversed.

MENU POSITION

Selects the display position of the menu from TOP LEFT, BOTTOM LEFT, CENTER, TOP RIGHT and BOTTOM RIGHT.

MENU COLOR

Selects the tone of the menu display from STANDARD, WARM, COOL, GREEN or GRAY.

MENU BACKGRND

Selects the intensity of the background picture of the menu display from DARK, STANDARD or LIGHT.

LAMP TIMER

Indicates how long the lamp has been turned on.

Note

This only displays the time. You cannot alter the display.

Installation Example

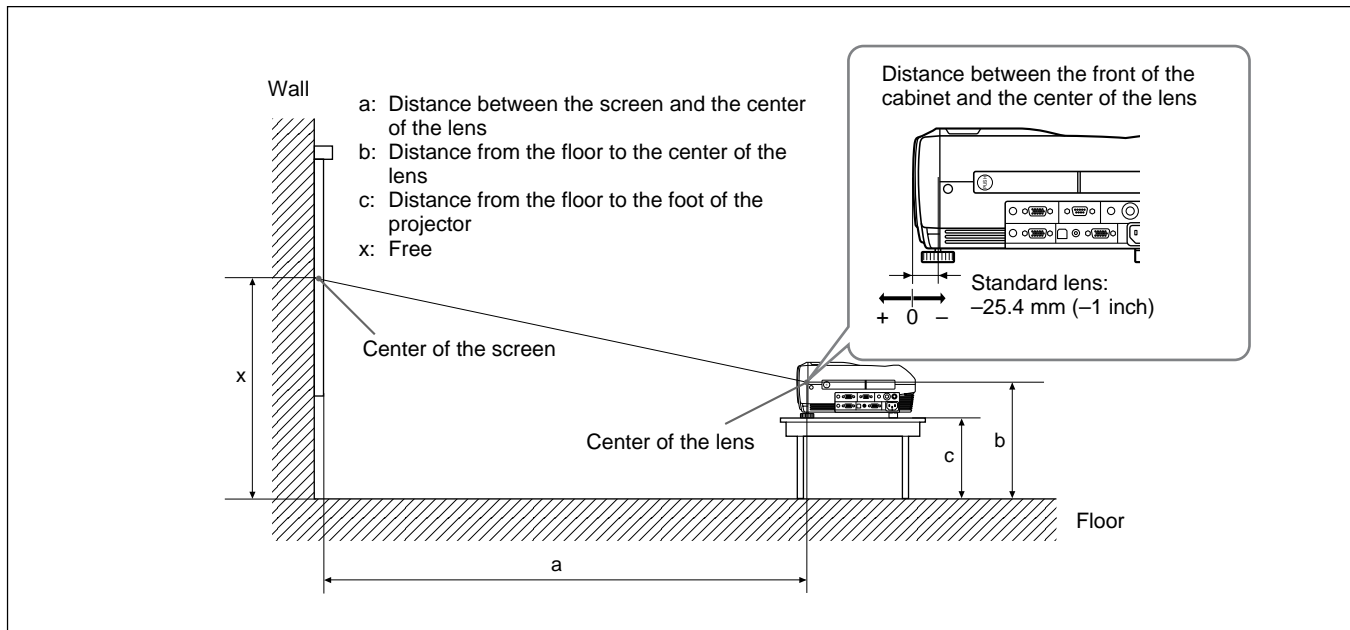

Unit: mm (inches)

SS		40	60	80	100	120	150	180	200	250	300
a	Minimum	1458 (57 1/2)	2217 (87 1/2)	2977 (117 3/8)	3736 (147 3/8)	4495 (177 1/4)	5635 (221 3/4)	6774 (266 5/8)	7533 (296 1/2)	9432 (371 3/8)	11330 (446 1/8)
	Maximum	1764 (69 3/8)	2675 (105 1/4)	3586 (141 3/8)	4497 (177 1/4)	5408 (213 1/8)	6774 (266 5/8)	8141 (320 5/8)	9052 (356 3/8)	11329 (446 1/8)	13607 (536)
b		x-305 (x-12)	x-457 (x-18)	x-610 (x-24)	x-762 (x-30)	x-914 (x-36)	x-1143 (x-45)	x-1372 (x-54)	x-1524 (x-60)	x-1905 (x-75 1/8)	x-2286 (x-90 1/8)
c		x-388 (x-15 3/8)	x-541 (x-21 3/8)	x-693 (x-27 3/8)	x-845 (x-33 3/8)	x-998 (x-39 3/8)	x-1226 (x-48 3/8)	x-1455 (x-57 3/8)	x-1607 (x-63 3/8)	x-1988 (x-78 3/8)	x-2369 (x-93 3/8)

To calculate the installation measurements (unit: mm)

SS: screen size diagonal (inches)

$$a \text{ (minimum)} = \{(SS \times 33.60/0.9071) - 59.7012\} \times 1.025$$

$$a \text{ (maximum)} = \{(SS \times 42.376846/0.9071) - 59.62151\} \times 0.975$$

$$b = x - (SS/0.9071 \times 6.912)$$

$$c = x - (SS/0.9071 \times 6.912 + 83.4)$$

Notes for Installation

Unsuitable Installation

Do not install the projector in the following situations. These installations may cause malfunction or damage to the projector.

Poorly ventilated

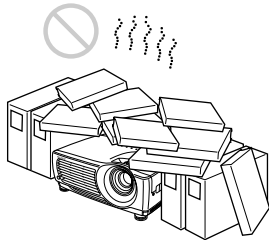

- Allow adequate air circulation to prevent internal heat build-up. Do not place the unit on surfaces (rugs, blankets, etc.) or near materials (curtains, draperies) that may block the ventilation holes. When internal heat builds up due to blockage of the ventilation holes, the temperature sensor may function, a warning message will be displayed, and the power may be turned off automatically after one minute.
- Leave space of more than 50 cm (19 ³/₄ inches) around the unit.
- Be careful that the ventilation holes do not inhale tiny objects such as pieces of paper.

Highly heated and humid

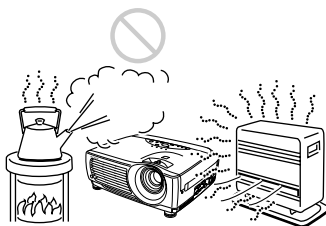

- Avoid installing the unit in a location where the temperature or humidity is very high, or the temperature is very low.
- To avoid moisture condensation, do not install the unit in a location where the temperature may rise rapidly.

Very dusty



Avoid installing the unit in a location where there is a lot of dust; otherwise, the air filter will clog. The dust blocking the air through the filter may cause the internal heat level of the projector to rise. Clean the filter periodically.

Unsuitable Conditions for Use

Do not do any of the following.

Toppling the unit

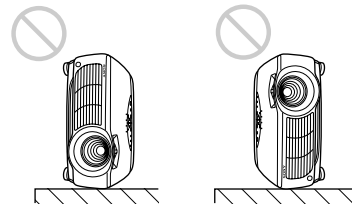

Avoid standing the unit on its side as the unit may topple over. This may cause a malfunction.

Tilting the unit more than 15 degrees

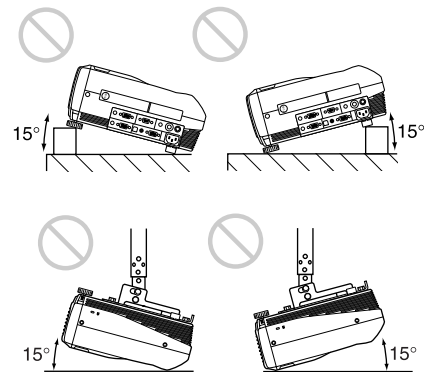

Avoid tilting the unit at an angle of more than 15 degrees. Installation of the unit in this manner may cause a malfunction.

Blocking the ventilation holes

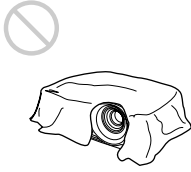

Avoid using something that covers over the ventilation holes (exhaust/intake); otherwise, the internal heat level may build up.

Removing the adjusters

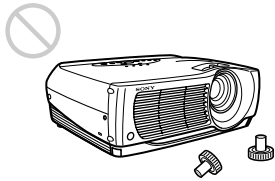

Avoid using the unit with the adjusters removed. Blocking the ventilation holes (intake) may cause internal heat build-up.



Maintenance

Notes

- If the lamp breaks, consult with qualified Sony personnel.
- Pull out the lamp unit by holding the handle. If you touch the lamp unit, you may be burned or injured.
- When removing the lamp unit, make sure it remains horizontal, then pull straight up. Do not tilt the lamp unit. If you pull out the lamp unit while it is tilted and if the lamp breaks, the pieces may scatter, causing injury.

Replacing the Lamp

When the lamp has burnt out or dims, or “Please replace the LAMP.” appears on the screen, replace the lamp with a new one. The lamp life varies depending on conditions of use. The message appears after 1500 hours of use.

Use an LMP-P202 Projector Lamp as the replacement lamp.

When replacing the lamp after using the projector

Turn off the projector, then unplug the power cord. Wait for at least an hour for the lamp to cool.

Note

The lamp remains at a high temperature after you turn off the projector with the I /  key. If you touch the lamp, you may burn your finger. When you replace the lamp, wait for at least an hour for the lamp to cool.

- 1 Place a protective sheet (cloth) beneath the projector. Hold the projector handle and place the projector face down.

Note

When replacing the lamp, be sure the projector is on a flat and stable surface.

- 2 Slide open the lamp cover after loosening its screw with a Phillips screwdriver.

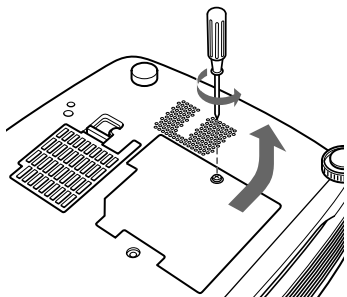

- 3 Loosen the screws on the lamp unit with the Phillips screwdriver.

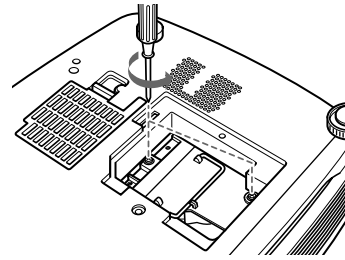

- 4 While holding the handle and keeping the lamp unit horizontal, pull straight up.

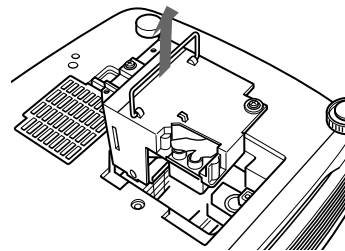

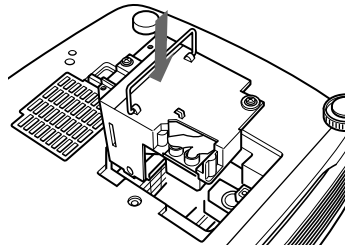

- 5 Insert the new lamp all the way in until it is securely in place. Tighten the two screws. Fold down the handle.



Notes

- Be careful not to touch the glass surface of the lamp.
- The power will not turn on if the lamp is not secured properly.

- 6 Close the lamp cover and tighten the screw.
- 7 Turn the projector back over.
- 8 Connect the power cord and turn the projector to the standby mode.
- 9 Press the following keys on the control panel in the following order for less than five seconds each: RESET, , , ENTER.

Notes

- Be sure to use an LMP-P202 Projector Lamp for replacement. If you use lamps other than the LMP-P202, the projector may malfunction.
- Be sure to turn off the projector and unplug the power cord before replacing the lamp.
- Do not put your hands into the lamp replacement socket, and do not allow any liquid or objects to fall into it to avoid electrical shock or fire.

Disposal of a used projector lamp

As the materials used in this lamp are similar to those of a fluorescent lamp, you should dispose of a used projector lamp in the same way as a fluorescent lamp.

Cleaning the Air Filter

The air filter should be cleaned every 300 hours.

When it becomes difficult to remove the dust from the filter, replace the filter with a new one.

To clean the air filter, follow the steps below:

- 1** Turn off the power and unplug the power cord.
- 2** Remove the air filter cover at the bottom of the projector.

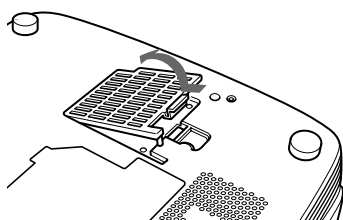

- 3** Remove the air filter.

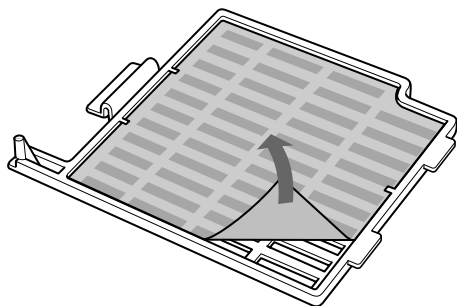

- 4** Wash the air filter with a mild detergent solution and dry it in a shaded place.

- 5** Hook the air filter on the holders of the air filter cover, then set the filter and replace the cover.

Notes

- If the dust cannot be removed from the air filter, replace the air filter with the supplied new one.
- Be sure to attach the air filter cover firmly; the power cannot be turned on if it is not closed securely.
- Place the air filter so that it fits in a notch on the air filter cover.

To clean the ventilation holes

When you clean the air filter, clean the ventilation holes (intake, rear and bottom) also. Remove the dust from the outside of the ventilation holes with a vacuum cleaner.

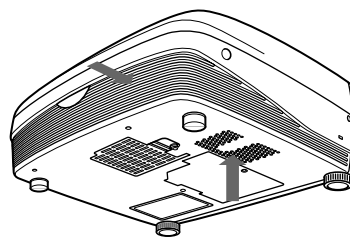

Troubleshooting

If you encounter a problem during operation, press the HELP key to display the help messages.

You can get these kinds of help messages:

- Image: A menu is not displayed. Colors are not correct.
- Sound: Sound is not output correctly.
- Other: The indicator lights up/flashes.

If you still have a problem after consulting the help messages, please check the following. If the problem persists, contact your Sony dealer.

Power

Symptom	Cause	Remedy
The power is not turned on.	The power has been turned off and on with the I / ⏻ key at too short an interval.	Wait for about 90 seconds before turning on the power (see page 20 (GB)).
	The lamp cover is detached.	Close the lamp cover securely (see page 32 (GB)).
	The air filter cover is detached.	Close the air filter cover securely (see page 33 (GB)).

Image

Symptom	Cause	Remedy
No picture.	A cable is disconnected or not connected properly.	Check that the proper connections have been made (see pages 15 (GB) to 18 (GB)).
	The input selection is incorrect.	Select the input source correctly using the INPUT key (see page 19 (GB)).
	The picture is cut off.	Press the PIC MUTING key on the Remote Commander to release the muting function (see page 13 (GB)).
	The computer signal is not set to output to an external monitor.	Set the computer signal to output to an external monitor (see page 15 (GB)).
	The computer signal is set to output to both the LCD of the computer and an external monitor.	Set the computer signal to output only to an external monitor (see page 15 (GB)).
	The 15k RGB/component equipment is connected to the INPUT B connector.	Connect the equipment to the INPUT A connector (see page 17 (GB)).
No picture appears on the external monitor.	The monitor channel selected is incorrect.	Select the correct monitor channel.
The picture is noisy.	Noise may appear on the background depending on the combination of the numbers of dot input from the connector and numbers of pixels on the LCD panel.	Change the desktop pattern on the connected computer.
On-screen display does not appear.	STATUS in the SET SETTING menu has been set to OFF.	Set STATUS in the SET SETTING menu to ON (see page 27 (GB)).
The color balance of the video picture is not correct.	The color system of the input signal is not set correctly.	Set COLOR SYS in the PICTURE CTRL menu to match the color system of the input signal (see page 24 (GB)).

Sound

Symptom	Cause	Remedy
No Sound.	A cable is disconnected or not connected properly.	Check that the proper connections have been made (see pages 15 (GB) to 18 (GB)).
There is no sound coming through the external monitor.	SPEAKER in the SET SETTING menu has been set to OFF.	Set SPEAKER to ON if necessary (see page 27 (GB)).
When inputting sound through the AUDIO jack, sound comes through one channel only.	Monaural sound is being input through the AUDIO jack.	Input stereo sound.

Others

Symptom	Cause	Remedy
The LAMP/COVER indicator flashes.	The lamp cover or the air filter cover is detached.	Attach the cover securely (see pages 32 (GB) and 33 (GB)).
The LAMP/COVER indicator lights up.	The lamp has reached the end of its life.	Replace the lamp (see page 32 (GB)).
	The lamp has reached too a high temperature.	Wait for 90 seconds to cool down the lamp and turn on the power again (see page 20 (GB)).
The TEMP/FAN indicator flashes.	The fan is broken.	Consult with qualified Sony personnel.
The TEMP/FAN indicator lights up.	The internal temperature is unusually high.	Check to see if nothing is blocking the ventilation holes.
Both LAMP/COVER and TEMP/FAN indicators light up.	The electrical system has failed.	Consult with qualified Sony personnel.

Warning messages

Use the list below to check the meaning of the messages displayed on the screen.

Message	Meaning	Remedy
High temp.! Lamp off in 1 min.	Internal temperature is too high.	Turn off the power. Check to see if something is blocking the ventilation holes.
Frequency is out of range!	This input signal cannot be projected as the frequency is out of the acceptable range of the projector.	Input a signal that is within the frequency range.
	The resolution setting of the output signal of the computer is too high.	Set the setting of output to XGA (see page 15 (GB)).
Please check INPUT-A setting.	You have input an RGB signal from the computer when INPUT-A in the SET SETTING menu is set to COMPONENT or VIDEO GBR.	Set INPUT-A correctly (see page 27 (GB)).
Please replace the LAMP.	It is time to replace the lamp.	Replace the lamp.

Caution messages

Use the list below to check the meaning of the messages displayed on the screen.

Message	Meaning	Remedy
NO INPUT	No input signal	Check connections (see pages 15 (GB) to 18 (GB)).
Not applicable!	You have pressed the wrong key.	Press the appropriate key.
SPEAKER OFF	SPEAKER in the SET SETTING menu has been set to OFF.	Set SPEAKER to ON if necessary (see page 27 (GB)).

Specifications

Optical characteristics

Projection system	3 LCD panels, 1 lens, projection system
LCD panel	0.9-inch TFT LCD panel with micro-lens array, 2,359,296 pixels (786,432 pixels × 3)
Lens	1.3 times zoom lens (manual) f 33.6 to 42 mm/F 1.7 to 2.1
Lamp	200 W UHP
Projection picture size	Range: 40 to 300 inches (diagonal measure)
Light output	ANSI lumen ¹⁾ 2000 lm
Throwing distance	40-inch: 1458 to 1764 mm (57 1/2 to 69 3/8 inches) 60-inch: 2217 to 2675 mm (87 1/2 to 105 1/4 inches) 80-inch: 2977 to 3586 mm (117 3/8 to 141 3/8 inches) 100-inch: 3736 to 4497 mm (147 3/8 to 177 1/4 inches) 120-inch: 4495 to 5408 mm (177 1/4 to 213 1/8 inches) 150-inch: 5635 to 6774 mm (221 3/4 to 266 5/8 inches) 180-inch: 6774 to 8141 mm (266 5/8 to 320 5/8 inches) 200-inch: 7533 to 9052 mm (296 1/2 to 356 3/8 inches) 250-inch: 9432 to 11329 mm (371 3/8 to 446 1/8 inches) 300-inch: 11330 to 13607 mm (446 1/8 to 536 inches)

Electrical characteristics

Color system	NTSC _{3.58} /PAL/SECAM/NTSC _{4.43} /PAL-M/PAL-N system, switched automatically/manually
Resolution	750 horizontal TV lines (Video input) 1024 × 768 dots (RGB input)
Acceptable range for computer signals	fH: 19 to 92 kHz fV: 48 to 92 Hz (Input resolution signal: SXGA 1280 × 1024 fV: 85 Hz, maximum)
Acceptable settings for video signals	15kHz RGB/ component 50/60 Hz, Composite video, Y/C video
Speaker	Stereo speakers system, 28 mm (1 1/8 inches) diameter, max. 2 W × 2

Input/Output

VIDEO IN	S VIDEO: Y/C mini DIN 4-pin type (female) Y (luminance): 1 Vp-p ±2 dB sync negative (75 ohms terminated) C (chrominance): burst 0.286 Vp-p ±2 dB (NTSC) (75 ohms terminated), burst 0.3 Vp-p ±2 dB (PAL) (75 ohms terminated) VIDEO: phono type Composite video: 1 Vp-p ±2 dB sync negative (75 ohms terminated) AUDIO: Stereo minijack 500 mVrms, impedance more than 47 kilohms
INPUT A	INPUT A: HD D-sub 15-pin (female) Analog RGB/component: R/R-Y: 0.7 Vp-p ±2 dB (75 ohms terminated) G: 0.7 Vp-p ±2 dB (75 ohms terminated) G with sync/Y: 1 Vp-p ±2 dB sync negative (75 ohms terminated) B/B-Y: 0.7 Vp-p ±2 dB (75 ohms terminated)

1) ANSI lumen is a measuring method of American National Standards Institute IT7.228.

	<p>SYNC/HD: Composite sync input: 1-5 Vp-p high impedance, positive/negative</p> <p>Horizontal sync input: 1-5 Vp-p high impedance, positive/negative</p> <p>VD: Vertical sync input: 1-5 Vp-p high impedance, positive/negative</p> <p>AUDIO: Stereo minijack 500 mVrms, impedance more than 47 kilohms</p>	<p>Safety regulations</p> <p>UL1950</p> <p>cUL (CSA No. 950)</p> <p>FCC Class A</p> <p>IC Class A</p> <p>NEMKO (EN60950)</p> <p>CE (LVD, EMC)</p> <p>C-Tick</p>
INPUT B	<p>INPUT B: HD D-sub 15-pin (female)</p> <p>Analog RGB:</p> <p>R: 0.7 Vp-p ± 2 dB (75 ohms terminated)</p> <p>G: 0.7 Vp-p ± 2 dB (75 ohms terminated)</p> <p>G with sync: 1 Vp-p ± 2 dB sync negative (75 ohms terminated)</p> <p>B: 0.7 Vp-p ± 2 dB (75 ohms terminated)</p> <p>SYNC/HD: Composite sync input: 1-5 Vp-p high impedance, positive/negative</p> <p>Horizontal sync input: 1-5 Vp-p high impedance, positive/negative</p> <p>VD: Vertical sync input: 1-5 Vp-p high impedance, positive/negative</p> <p>AUDIO: Stereo minijack 500 mVrms, impedance more than 47 kilohms</p>	<hr/> <p>General</p> <p>Dimensions 325 \times 110 \times 285 mm (12 $\frac{7}{8}$ \times 4 $\frac{3}{8}$ \times 11 $\frac{1}{4}$ inches) (w/h/d) (without the projection parts)</p> <p>Mass Approx. 4.9 kg (10 lb 13 oz)</p> <p>Power requirements AC 100 to 240 V, 2.9–1.2 A, 50/60 Hz</p> <p>Power consumption Max. 290 W (Standby mode: 4.7 W)</p> <p>Heat dissipation 989.6 BTU</p> <p>Operating temperature 0 $^{\circ}$C to 35 $^{\circ}$C (32 $^{\circ}$F to 95 $^{\circ}$F)</p> <p>Operating humidity 35 % to 85 % (no condensation)</p> <p>Storage temperature -20 $^{\circ}$C to 60 $^{\circ}$C (-4 $^{\circ}$F to 140 $^{\circ}$F)</p> <p>Storage humidity 10 % to 90 %</p> <p>Supplied accessories</p> <p>Remote Commander (1)</p> <p>R6 (Size AA) batteries (2)</p> <p>HD D-sub 15-pin cable (2 m) (1) (1-791-992-31)</p> <p>USB cable A type – B type (1) (1-790-081-31)</p> <p>CD-ROM (Application software) (1)</p> <p>AC power cord (1)</p> <p>Air filter (for replacement) (1)</p> <p>Lens cap (1)</p> <p>Operating Instructions (1)</p> <p>Installation Manual for Dealers (1)</p> <p>Quick Guide (1)</p>
OUTPUT	<p>MONITOR: HD D-sub 15-pin (female)</p> <p>Analog RGB/Component:</p> <p>R/R-Y, G/Y, B/B-Y: Gain Unity, 75 ohms</p> <p>SYNC/HD, VD: 4 Vp-p (open), 1 Vp-p (75 ohms)</p> <p>AUDIO (variable out): Stereo minijack, max. 1 Vrms, When an output signal is 500 mVrms, impedance less than 5 kilohms</p>	
REMOTE	<p>RS-232C: D-sub 9-pin (female)</p>	<p>Design and specifications are subject to change without notice.</p>

Optional accessories

Projector Lamp LMP-P202 (for replacement)

Projector Suspension Support PSS-610

Monitor Cable

SMF-410 (HD D-sub 15-pin (male) ↔ HD D-sub 15-pin (male))

Signal Cable

SMF-402 (HD D-sub 15-pin (male) ↔ 3 × phono jack)

Projection Lens

Short Focal Length Converter Lens VPLL-CW10

Long Focal Length Converter Lens VPLL-CT10

Some of the items may not be available in some areas. For details, please consult your nearest Sony dealer.

Pin assignment

INPUT A connector (HD D-sub 15-pin, female)

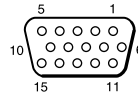

1	R/R-Y	9	N.C.
2	G/Y	10	GND
3	B/B-Y	11	GND
4	GND	12	DDC/SDA
5	GND	13	HD/C.Sync
6	GND (R)	14	VD
7	GND (G)	15	DDC/SCL
8	GND (B)		

REMOTE (RS-232C control) connector (D-sub 9-pin, female)

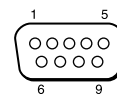

1	DCD	6	DSR
2	RxDA	7	RTS
3	TxDA	8	CTS
4	DTR	9	RI
5	GND		

Index

A

Adjuster 10 (GB)
 Adjusting
 retention of the settings 22 (GB)
 the picture 20 (GB), 23 (GB)
 the picture size/shift 20 (GB), 25 (GB)
 Air filter 33 (GB)
 APA function 20 (GB)
 ASPECT 25 (GB)
 AUTO INPUT SEL 27 (GB)

B

Battery
 installation 14 (GB)
 notes 14 (GB)
 BRIGHT 23 (GB)

C

Carrying handle 9 (GB)
 COLOR 23 (GB)
 COLOR SYS (System) 24 (GB)
 COLOR TEMP 23 (GB)
 Condensation 30 (GB)
 Connections
 component equipment 17 (GB)
 computer 15 (GB)
 monitor 18 (GB)
 VCR 17 (GB)
 CONTRAST 23 (GB)
 Cut off the picture 19 (GB)

D, E, F

DIGIT KEYSTONE 28 (GB)
 D. (Dynamic) PICTURE 23 (GB)
 DOT PHASE 24 (GB)
 Freeze function 21 (GB)

G

GAMMA MODE 23 (GB)

H

HUE 23 (GB)

I, J, K

INPUT-A 27 (GB)
 INPUT SETTING menu 24 (GB)
 INSTALL SETTING menu 27 (GB)
 INSTALLATION 28 (GB)
 Installation example 29 (GB)
 IR RECEIVER 27 (GB)
 KEYSTONE MEM 28 (GB)

L

Lamp replacement 32 (GB)
 LAMP TIMER 28 (GB)
 LANGUAGE 27 (GB)
 Location and function of controls
 connector panel 12 (GB)
 control panel 11 (GB)
 front / left side 9 (GB)
 rear / right side / bottom 9 (GB)
 Remote Commander 13 (GB)

M, N

Menu
 clearing the menu display 22 (GB)
 INPUT SETTING menu 24 (GB)
 INSTALL SETTING menu 27 (GB)
 PICTURE CTRL menu 23 (GB)
 SET SETTING menu 26 (GB)
 using the menu 22 (GB)
 MENU BACKGRND 28 (GB)
 MENU COLOR 28 (GB)
 MENU POSITION 28 (GB)
 Messages
 cautions 35 (GB)
 warnings 35 (GB)
 Notes for installation
 unsuitable conditions for use 30 (GB)
 unsuitable installation 30 (GB)

O

Off and Go function 20 (GB)
 Optional accessories 38 (GB)

P, Q

PICTURE CTRL menu 23 (GB)
 Pin assignment 38 (GB)
 Power
 turn off 20 (GB)
 turn on 18 (GB)
 POWER SAVING 11 (GB), 27 (GB)
 Precautions 7 (GB)
 Projecting 19 (GB)

R

Remote Commander 13 (GB)
 Remote control detector
 front 9 (GB)
 rear 9 (GB)
 setting 27 (GB)
 Reset
 resettable items 22 (GB)
 resetting the item 22 (GB)
 RGB ENHANCER 23 (GB)

S

SCAN CONV (Scan converter) 25 (GB)
 Screen size 36 (GB)
 SET SETTING menu 26 (GB)
 SHARP 23 (GB)
 SHIFT 25 (GB)
 SIZE H 25 (GB)
 SPEAKER 27 (GB)
 Specifications 36 (GB)
 STATUS (on-screen display) 27 (GB)
 Supplied accessories 37 (GB)

T, U

Troubleshooting 34 (GB)

V, W, X, Y, Z

Ventilation holes
 exhaust 9 (GB)
 intake 10 (GB)
 VOLUME 24 (GB)