

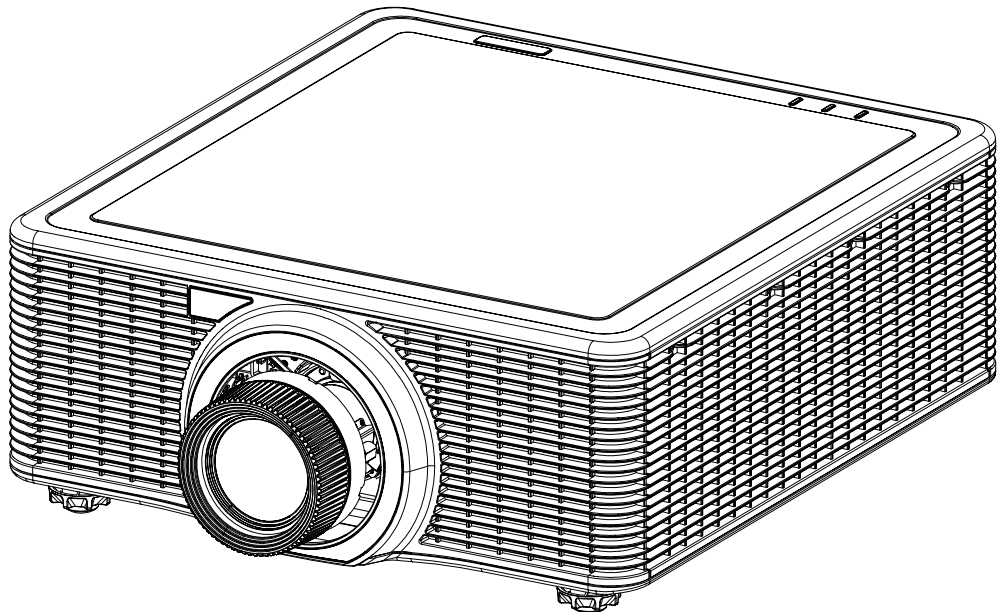

Owner's Manual



Multimedia Projector

Model EK-625U

(Projection lens is optional.)

Features and Design

This Multimedia Projector is designed with the most advanced technology for portability, durability, and ease of use. This projector utilizes a high luminance and Eco friendly system, a palette of 1.07 billion colors, and digital light processing (DLP) technology.

Compact Design

This projector is designed compact in size and weight. It is easy to carry and installed anywhere you wish to use.

Simple Computer System Setting

The projector has the Multi-scan system to conform to almost all computer output signals quickly. Up to WUXGA and WXGA resolutions can be accepted.

Useful Functions for Presentations

The digital zoom function allows you to focus on the crucial information during a presentation.

Laser Diode Control

Brightness of the projection laser diode can be manually selected (Constant Power, Constant Luminance, or Eco Mode).

Logo Function

The Logo function allows you to specify the screen background ("Logo", "Blue", "Black", or "White" screen) when no signal is available.

Multilanguage Menu Display

Operation menu is available in 13 languages; English, French, Spanish, German, Italian, Russian, Simplified Chinese, Japanese, Korean, Portuguese, Indonesian, Dutch, and Arabic.

Helpful Maintenance Function

Lens replacement function provides for better and proper maintenance of the projector.

Security Function

The Security function helps you ensure security of the projector.

LAN Network Function

This projector is loaded with the Wired LAN network function. You can operate and manage the projector via network.

For details, refer to page 43 and pages 47-54.

Auto Setup Function

This function enables auto input search and auto signal adjustment simply by pressing the Auto button on the remote control.

Power Management

The Power management function reduces power consumption and maintains the laser diode life.

Note:

*The screen menu and pictures in the manual may slightly differ from the real product.
The manual is subject to change without prior notice.*

Copyright

This publication, including all photographs, illustrations and software, is protected under international copyright laws, with all rights reserved. Neither this manual, nor any of the material contained herein, may be reproduced without written consent of the author.

© Copyright 2016

Disclaimer

The information in this document is subject to change without notice. The manufacturer makes no representations or warranties with respect to the contents hereof and specifically disclaims any implied warranties of merchantability or fitness for any particular purpose. The manufacturer reserves the right to revise this publication and to make changes from time to time in the content hereof without obligation of the manufacturer to notify any person of such revision or changes.

Trademark Recognition

All other product names used in this manual are the properties of their respective owners and are acknowledged.

Important Safety Information

Important:

It is strongly recommended that you read this section carefully before using the projector. These safety and usage instructions will ensure that you enjoy many years of safe use of the projector. Keep this manual for future reference.

Symbols Used

Warning symbols are used on the unit and in this manual to alert you of hazardous situations. The following styles are used in this manual to alert you to important information.

Note:

Provides additional information on the topic at hand.

Important:

Provides additional information that should not be overlooked.

Caution:

Alerts you to situations that may damage the unit.

Warning:

Alerts you to situations that may damage the unit, create a hazardous environment, or cause personal injury.

Throughout this manual, component parts and items in the OSD menus are denoted in bold font as in this example:

“Push the **Menu** button on the remote control to open the **Main** menu.”

General Safety Information

- Do not open the unit case. There are no user-serviceable parts in the unit. For servicing, contact qualified service personnel.
- Follow all warnings and cautions in this manual and on the unit case.
- The projection laser diode is extremely bright by design. To avoid damage to eyes, do not look into the lens when the laser diode is on.
- Do not place the unit on an unstable surface, cart, or stand.
- Avoid using the system near water, in direct sunlight, or near a heating device.
- Do not place heavy objects such as books or bags on the unit.

Safety Instructions

- Please read this manual completely before installing and operating the projector.
- The projector provides many convenient features and functions. Proper operation may enable you to fully utilize the features and keep it in good condition. Otherwise, it will not only shorten the service life of the unit, but also may cause malfunction, a fire, or other accidents.
- If your projector cannot work properly, please read this manual again, check the operating methods and cable connection, and try the solutions in the part of Troubleshooting. If the problem still exists, contact the dealer or the service center.

Caution:



ELECTRIC SHOCK DO NOT OPEN



Caution:

To reduce the risk of electric shock, do not remove cover (or back), no user serviceable parts inside. Refer servicing to qualified service personnel.



This symbol indicates that dangerous voltage constituting a risk of electric shock is present within this unit.



This symbol indicates that there are important operating and maintenance instructions in the user's manual with this unit.

FOR EU USERS

The symbol mark and recycling systems described below apply to EU countries and do not apply to countries in other areas of the world.

Your product is designed and manufactured with high quality materials and components which can be recycled and/or reused.

The symbol mark means that electrical and electronic equipment, batteries and accumulators, at their end-of-life, should be disposed of separately from your household waste.

Note:

If a chemical symbol is printed beneath the symbol mark, this chemical symbol means that the battery or accumulator contains a heavy metal at a certain concentration. This will be indicated as follows: Hg: mercury, Cd: cadmium, Pb: lead In the European Union there are separate collection systems for used electrical and electronic equipment, batteries and accumulators. Please, dispose of them correctly at your local community waste collection/recycling centre. Please help us to conserve the environment we live in!

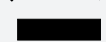



Safety Precautions

Caution:

- The projector must be grounded.
 - Do not expose the projector to raindrops or high humidity to avoid a fire or electric shock.
- This projector produces intense light from the projection lens. Avoid staring directly into the lens, otherwise eye damage could be caused. Be especially careful that children do not stare directly into the beam.
 - Place the projector in a proper position. Otherwise it may result in fire hazard.
 - Leave an appropriate space from the top, sides, and back of the shell in order to ventilate and cool down the projector. The figures below indicate the minimum distance to be left. It must be satisfied if the projector is placed in sealed environment like a cabinet.

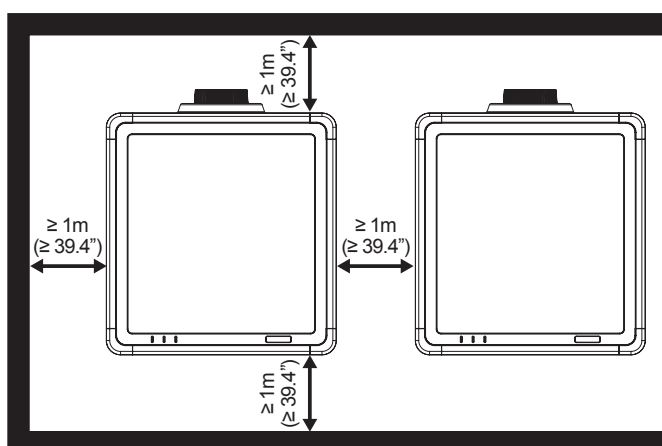

- Do not cover the vent of the projector. Poor radiation may shorten the service life or even cause dangers.
- Remove the AC power plug if the projector is not to be used for a long time.



Caution:

- Do not set the projector in greasy, wet, or smoky conditions such as in a kitchen, to prevent a malfunction or accident. If the projector comes in contact with oil or chemicals, it may become deteriorated.
- Read and keep this manual for future reference.
- The mains plug/appliance coupler is used as disconnect device, the disconnect device shall remain readily operable.

Safety Guide

- All the safety and operating instructions should be read before the product is operated.
 - Read all of the instructions given here and retain them for later use. Unplug this projector from AC power supply before cleaning. Do not use liquid or aerosol cleaners.
 - Use a damp cloth for cleaning.
 - Follow all warnings and instructions marked on the projector.
 - For added protection to the projector during a lightning storm, or when it is left unattended and unused for long periods of time, unplug it from the wall outlet. This will prevent damage due to lightning and power line surges.
 - Do not expose this unit to rain or use near water... for example, in a wet basement, near a swimming pool, etc...
 - Do not use attachments not recommended by the manufacturer as they may cause hazards.
 - Do not place this projector on an unstable cart, stand, or table. The projector may fall, causing serious injury to a child or an adult, and serious damage to the projector.
- 
- Use only with a cart or stand recommended by the manufacturer, or sold with the projector. Wall or shelf mounting should follow the manufacturer's instructions, and should use a mounting kit approved by the manufacturers.
 - An appliance and cart combination should be moved with care. Quick stops, excessive force, and uneven surfaces may cause the appliance and cart combination to overturn.
 - Slots and openings in the back and bottom of the cabinet are provided for ventilation, to ensure reliable operation of the equipment and to protect it from overheating.
 - The openings should never be covered with cloth or other materials, and the bottom opening should not be blocked by placing the projector on a bed, sofa, rug, or other similar surface. This projector should never be placed near or over a radiator or heat register.
 - This projector should not be placed in a build-in installation such as a book case unless proper ventilation is provided.
 - Never push objects of any kind into this projector through cabinet slots as they may touch dangerous voltage points or short out parts that could result in a fire or electric shock. Never spill liquid of any kind on the projector.
 - Do not install the projector near the ventilation duct of air-conditioning equipment.
 - This projector should be operated only from the type of power source indicated on the marking label.
 - If you are not sure of the type of power supplied, consult your authorized dealer or local power company.
 - Do not overload wall outlets and extension cords as this can result in fire or electric shock. Do not allow anything to rest on the power cord. Do not locate this projector where the cord may be damaged by persons walking on it.
 - Do not attempt to service this projector yourself as opening or removing the covers may expose you to dangerous voltage or other hazards. Refer all servicing to qualified service personnel.
 - Unplug this projector from wall outlet and refer servicing to qualified service personnel under the following conditions:
 - When the power cord or plug is damaged or frayed.
 - If liquid has been spilled into the projector.
 - If the projector has been exposed to rain or water.
 - If the projector does not operate normally by following the operating instructions. Adjust only those controls that are covered by the operating instructions as improper adjustment of other controls may result in damage and will often require extensive work by a qualified technician to restore the projector to normal operation.
 - If the projector has been dropped or the cabinet has been damaged.

- When the projector exhibits a distinct change in performance - this indicates a need for service.
- When replacement parts are required, be sure the service technician has used replacement parts specified by the manufacturer that have the same characteristics as the original part. Unauthorized substitutions may result in fire, electric shock, or injury to persons.
- Upon completion of any service or repairs to this projector, ask the service technician to perform routine safety checks to determine that the projector is in safe operating condition.

Information for users in the European Union

This is a device to project images onto a screen, etc., and is not intended for use as indoor lighting in a domestic environment.

Directive 2009/125/EC.

Air circulation

Vents in the cabinet are provided for ventilation. To ensure reliable operation of the product and to protect it from overheating, these openings must not be blocked or covered.



Caution:

- *Hot air is exhausted from the exhaust vent. When using or installing the projector, the following precautions should be taken.*
- *Do not put any flammable objects, or spray can near the projector. Hot air is exhausted from the air vents.*
- *Keep the exhaust vent at least 1m away from any objects.*
- *Do not touch a peripheral part of the exhaust vent, especially screws and metallic part. This area will become hot while the projector is being used.*
- *Do not put anything on the projector. Objects put on the cabinet will not only get damaged but also may cause fire hazard by heat.*
- *Cooling fans are provided to cool down the projector.*
- *The fan's running speed is changed according to the temperature inside the projector.*

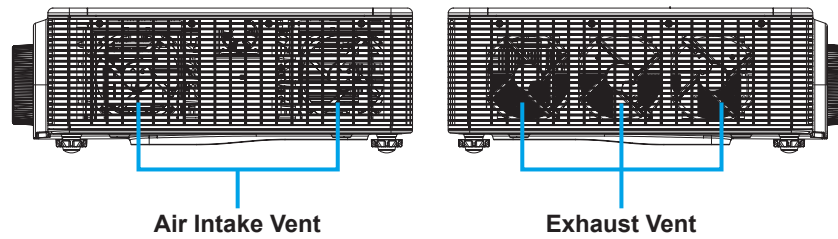

Moving the projector

When moving the projector, take care of the lens and retract the adjustable foot to prevent damage to the lens and cabinet.

Installing the projector properly

- Please set the projector on nearly-level.
- Be sure to install the projector properly. Improper installation may reduce the laser diode lifetime and even cause a fire hazard.



Caution in ceiling installation the projector

- *Only qualified personal is authorized for ceiling installation.*
- *We are not responsible for the hurt and damage caused by ceiling bracket that purchased from unauthorized dealer even in warranty period.*
- *Remove the ceiling bracket immediately while not use.*
- *While installing, torque screwdriver is suggested, don't use electric or impact-type screwdriver.*
- *Please read the manual of bracket for details.*
- *The bracket is subject to change without notice.*

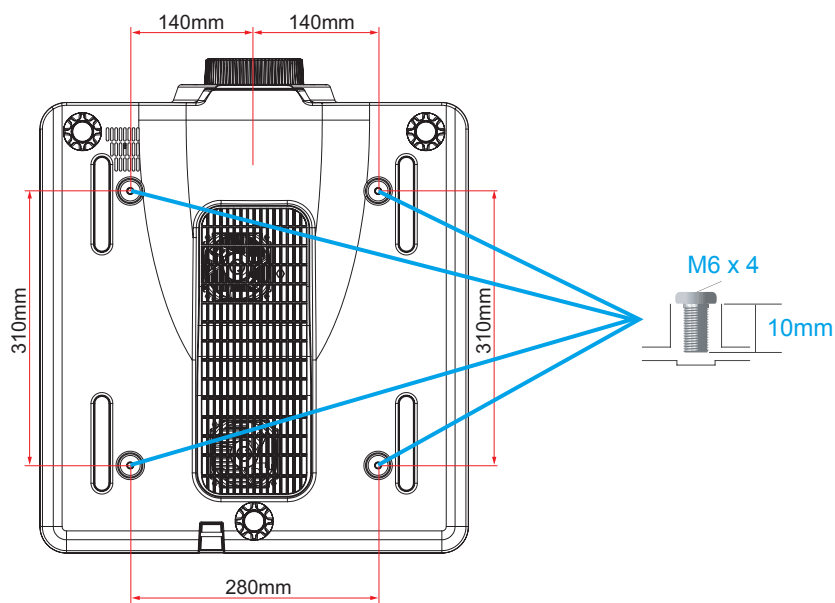
**Caution in moving or transporting the projector**

- Do not drop or bump the projector, otherwise damages or malfunctions may result.
- When carrying the projector, use a suitable carrying case.
- Do not transport the projector by courier or any other transport service in an unsuitable transport case. This may cause damage to the projector. For information about transporting the projector by courier or any other transport service, consult your dealer.

Important Information

Laser Safety Cautions

This product is classified as CLASS 1 LASER PRODUCT - RISK GROUP 2 of IEC 60825-1:2014 and also complies with 21 CFR 1040.10 and 1040.11 as a Risk Group 2, LIP (Laser Illuminated Projector) as defined in IEC 62471:2006 except for deviations pursuant to Laser Notice No. 50, dated June 24, 2007.



IEC 60825-1:2014 CLASS 1 LASER PRODUCT RISK GROUP 2
Complies with 21 CFR 1040.10 and 1040.11 as a Risk Group 2, LIP
(Laser Illuminated Projector) as defined in IEC 62471:2006 except for deviations
pursuant to Laser Notice No. 50, dated June 24, 2007
CAUTION
Possibly hazardous optical radiation emitted from this product. Do not stare at
operating beam. May be harmful to the eyes.

IEC 60825-1:2014 PRODUIT LASER DE CLASSE 1 GROUPE DE RISQUE 2
Conforme aux normes 21 CFR 1040.10 et 1040.11 comme Groupe de risque 2,
projecteur laser (LIP, Laser Illuminated Projector) défini par CEI 62471:
2006 sauf les exceptions citées dans le document Laser Notice N° 50, daté du 24 Juin 2007.
AVERTISSEMENT
Rayonnement optique dangereux potentiel émis par ce produit. Ne pas regarder
directement dans le faisceau. Ceci pourrait être nocif pour les yeux.

IEC 60825-1:2014 1类激光产品RG2危险等级
除了根据激光公告第50号,日期2007年6月24日之差异外,符合 21 CFR 1040.10和1040.11同
IEC 62471:2006所定义之LIP (激光照明投影机) RG2危险等级。
注意
此产品可能会产生危险激光辐射。请勿直视操作光束,以免对眼睛损害。

- This projector has built-in Class 4 laser module. Disassembly or modification is very dangerous and should never be attempted.
- Any operation or adjustment not specifically instructed in the user's guide creates the risk of hazardous laser radiation exposure.
- Do not open or disassemble the projector as this may cause damage by the exposure of laser radiation.
- Do not stare into beam when the projector is on. The bright light may result in permanent eye damage.
- When turning on the projector, make sure no one within projection range is looking at the lens.
- Without following the control, adjustment or operation procedure may cause damage by the exposure of laser radiation.
- Adequate instructions for the assembly, operation, and maintenance, including clear warnings concerning precautions to avoid possible exposure to laser.

Compliance

FCC Caution

Note: This equipment has been tested and found to comply with the limits for a Class A digital device, pursuant to Part 15 of the FCC Rules. These limits are designed to provide reasonable protection against harmful interference in a residential installation. This equipment generates, uses, and can radiate radio frequency energy, and if not installed and used in accordance with the instructions, may cause harmful interference to radio communications. However, there is no guarantee that interference will not occur in a particular installation. If this equipment does cause harmful interference to radio or television reception, which can be determined by turning the equipment off and on, the user is encouraged to try to correct the interference by one or more of the following measures:

- Reorient or relocate the receiving antenna.
- Increase the separation between the equipment and receiver.
- Connect the equipment into an outlet on a circuit different from that to which the receiver is connected.
- Consult the dealer or an experienced radio/TV technician for help.

Use of shielded cable is required to comply with class A limits in Subpart B of Part 15 of FCC Rules.

Do not make any changes or modifications to the equipment unless otherwise specified in the instructions. If such changes or modifications should be made, you could be required to stop operation of the equipment.

Model Number : EK-625U

Trade Name : EIKI

Responsible party : EIKI International, Inc.

Address : 30251 Esperanza Rancho Santa Margarita CA 92688-2132

Telephone No. : 800-242-3454 (949-457-0200)

Note:

*For use in a commercial, industrial or business environment.
Not for domestic use.*

AC Power Cord Requirement

The AC Power Cord supplied with this projector meets the requirement for use in the country you purchased it.

AC Power Cord for the United States and Canada:

AC Power Cord used in the United States and Canada is listed by the Underwriters Laboratories (UL) and certified by the Canadian Standard Association (CSA).

AC Power Cord has a grounding-type AC line plug. This is a safety feature to be sure that the plug will fit into the power outlet. Do not try to defeat this safety feature. Should you be unable to insert the plug into the outlet, contact your electrician.

Warning:

A plug with bared flexible cord is hazardous if engaged in a live socket outlet.

The Wires in this mains lead are coloured in accordance with the following code:

- Green-and-yellow Earth
- Blue Neutral
- Brown Live

As the colours of the wires in the mains lead of this apparatus may not correspond with the coloured markings identifying the terminals in your plug proceed as follows:

- The wire which is coloured green-and-yellow must be connected to the terminal in the plug which is marked by the letter E or by the safety earth symbol or coloured green or green-and-yellow.
- The wire which is coloured blue must be connected to the terminal which is marked with the letter N or coloured black.
- The wire which is coloured brown must be connected to the terminal which is marked with the letter L or coloured red.

Warning:

This apparatus must be earthed.

Note:

The socket-outlet should be installed near the equipment and easily accessible.

Contents

GETTING STARTED.....	1
PACKING CHECKLIST.....	1
VIEWS OF PROJECTOR PARTS.....	2
Front-right View	2
Rear View	3
Built-in Keypad.....	4
Bottom View.....	5
REMOTE CONTROL PARTS	6
REMOTE CONTROL OPERATING RANGE.....	8
PROJECTOR AND REMOTE CONTROL BUTTONS.....	8
REMOTE CONTROL CODE.....	8
INSERTING THE REMOTE CONTROL BATTERIES	9
SETUP AND OPERATION	10
INSTALLING THE PROJECTION LENS.....	10
STARTING AND SHUTTING DOWN THE PROJECTOR	12
Turn the Projector On	12
Turn the Projector Off	12
ADJUSTING THE PROJECTOR LEVEL.....	13
ADJUSTING THE ZOOM, FOCUS, AND KEYSTONE	14
USING THE LENS SHIFT ADJUSTMENT	15
Vertical / Horizontal Lens Shift.....	15
OPTIONAL LENSES AND PROJECTION SIZE.....	17
Projection Lens.....	17
Projection Size v.s Throw Distance.....	19
ON-SCREEN DISPLAY (OSD) MENU SETTINGS	21
OSD MENU CONTROLS.....	21
Navigating the OSD.....	21
SETTING THE OSD LANGUAGE	22
OSD MENU OVERVIEW	23
PICTURE MENU	31
3D Display Menu	32
HSG Adjustment Menu	33
Advanced Menu.....	34

OUTPUT MENU	35
Image Warping Menu.....	36
PIP/PBP Menu.....	37
SETUP MENU	39
Lens Function Menu	40
Menu Preferences Menu	41
PIN Menu.....	42
Communications Menu	43
OPTION MENU.....	44
Power Settings Menu.....	45
Light Source Settings Menu.....	46
CONTROL YOUR PROJECTOR USING WEB BROWSER.....	47
Wired LAN Terminal functionalities	47
Supported External Devices	47
LAN_RJ45	48
RS232 by Telnet Function.....	52
MAINTENANCE AND SECURITY	55
REPLACING THE PROJECTION LENS	55
CLEANING THE PROJECTOR.....	56
Cleaning the Lens.....	56
Cleaning the Case	56
USING THE KENSINGTON® LOCK	57
TROUBLESHOOTING	58
COMMON PROBLEMS AND SOLUTIONS.....	58
TIPS FOR TROUBLESHOOTING	58
LED ERROR MESSAGES.....	59
IMAGE PROBLEMS	60
LASER DIODE PROBLEMS	60
REMOTE CONTROL PROBLEMS	61
HAVING THE PROJECTOR SERVICED	61
HDMI Q & A.....	62

SPECIFICATIONS	63
SPECIFICATIONS	63
PROJECTION DISTANCE VS. PROJECTION SIZE.....	64
Projection Distance and Size Table	64
TIMING MODE TABLE	66
PROJECTOR DIMENSIONS.....	69
REGULATORY COMPLIANCE	70
FCC WARNING.....	70
CANADA	70
SAFETY CERTIFICATIONS	70

GETTING STARTED

Packing Checklist

Carefully unpack the projector and check that the following items are included:

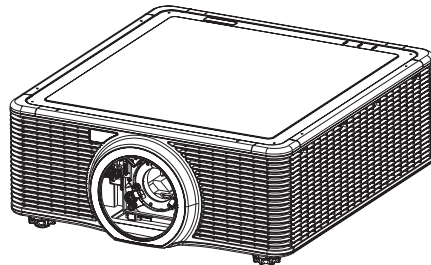

DLP PROJECTOR

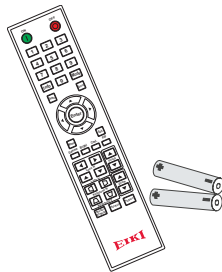

REMOTE CONTROL
(WITH TWO AAA
BATTERIES)

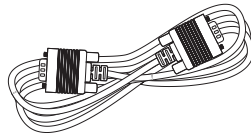

VGA CABLE

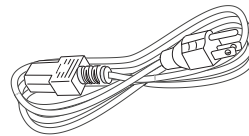

POWER CORD

* For other regions except China:
POWER CORD x 2 (US and EU)
* For China: POWER CORD x 1

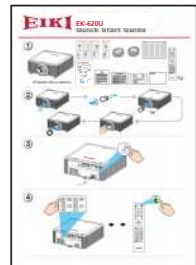

QUICK START GUIDE

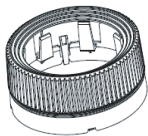

LENS COVER
* For A01, A02, A03, A05,
and A13 lens

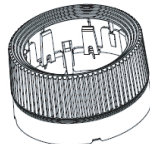

LENS COVER
* For A06 lens



CD-ROM
(THIS OWNER'S MANUAL)
for China



SAFETY GUIDE



WARRANTY CARD
for USA

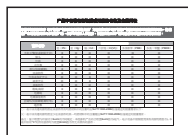

RoHS CARD
for China



QC PASS CARD
for China

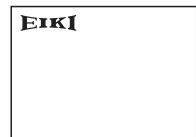

WARRANTY CARD
for China

Contact your dealer immediately if any items are missing, appear damaged, or if the unit does not work. It is recommend that you keep the original packing material should you ever need to return the equipment for warranty service.

Note:

- Avoid using the projector in dusty environments.

Views of Projector Parts

Front-right View

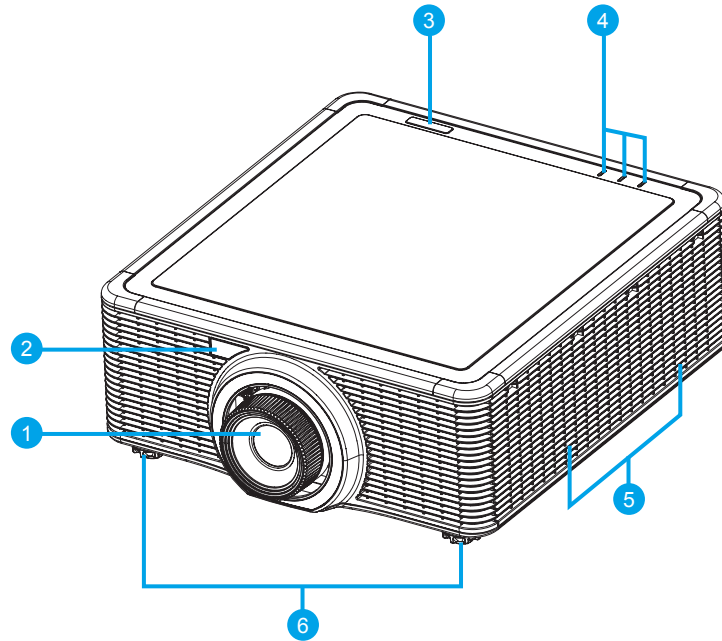

ITEM	LABEL	DESCRIPTION	SEE PAGE
1	Projection Lens	Allows automated lens control and adjustment: vertical and horizontal offsets, zoom and focus.	-
2	Front IR Sensor	Receives signals from the IR remote. Keep the signal path to the sensor unobstructed for uninterrupted communication with the projector.	6
3	Top IR Sensor		
4	LED Status Indicators	Displays the status of the projector.	59
5	Cooling Air Vents (Intake)	Keep these vents unobstructed to prevent the projector from overheating.	-
6	Adjustable Feet	Raise or lower the feet to level the projector.	13

Important:

Ventilation openings on the projector allow for good air circulation, which keeps the projector laser diode cool. Do not obstruct any of the ventilation openings.

Rear View

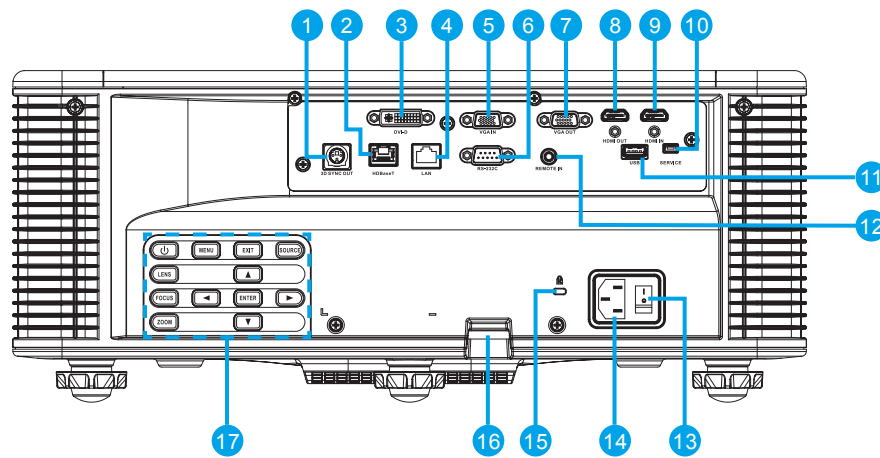

ITEM	LABEL	DESCRIPTION	SEE PAGE
1	3D Sync OUT	Connect the 3D IR glasses transmitter (Note: For Specific 3D IR glasses only)	-
2	HDBaseT	Connect a RJ45 Cat5/Cat6 Ethernet cable to input uncompressed high-definition video control signals.	-
3	DVI-D	Connect to DVI source.	-
4	LAN	Connect a LAN cable from Ethernet.	-
5	VGA IN	Connect the VGA cable from a computer or component device.	-
6	RS-232C	Connect RS-232 serial port cable for remote control.	-
7	VGA OUT	Connect the VGA cable to a display.	-
8	HDMI OUT	Connect the HDMI cable to a display.	-
9	HDMI IN	Connect the HDMI cable from a HDMI device.	-
10	Service	Service only.	-
11	USB	Connect the WIFI dongle.	-
12	Remote IN	Connect to the remote control wired terminal for serial control projector.	-
13	Power Switch	Switch the power button to turn on/off the power source.	12
14	AC Input	Connect to the supplied power adapter.	12
15	Kensington Lock	Use to secure the projector to countertops, tables, etc.	57
16	Security Bar	Use to secure the projector.	-
17	Built-in Keypad	Control the projector.	4

Note:

- To use this feature, you must plug in the power adapter/cable/cord before turn on/off the projector.
- Do not use this jack for anything other than intended use.

Warning:

As a safety precaution, disconnect all power to the projector and connecting devices before making connections.

Built-in Keypad

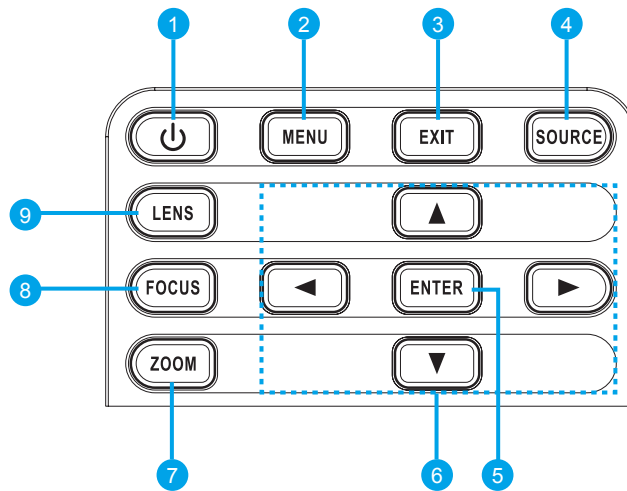

ITEM	LABEL	DESCRIPTION	SEE PAGE
1	Power	Turn the projector on or off.	12
2	Menu	Display menus.	21
3	Exit	Return to previous level or exit menus if at top level.	21
4	Source	Select an input for the main or PIP/PBP image.	-
5	Enter	<ul style="list-style-type: none"> • Select a highlighted menu item. • Change or accept a value. 	21
6	Arrow keys	<ul style="list-style-type: none"> • Adjust a setting UP or DOWN. • Navigate within a menu. 	21
7	Zoom	Adjust zoom.	14
8	Focus	Adjust focus.	14
9	Lens	Adjust the lens vertical or horizontal offset setting.	-

Bottom View

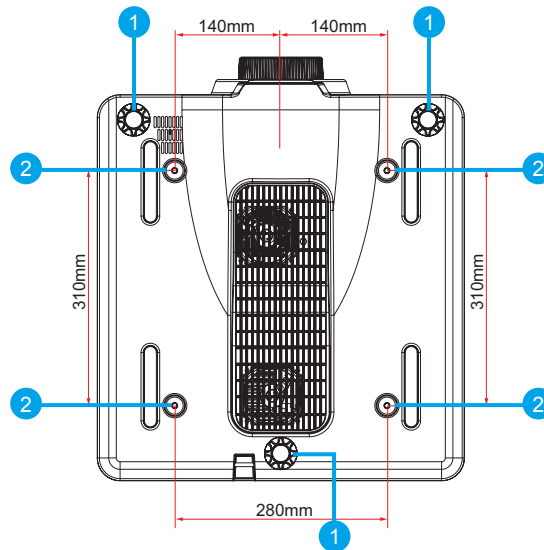

ITEM	LABEL	DESCRIPTION	SEE PAGE
1	Adjustable Feet	Raise or lower the feet to level the projector.	13
2	Ceiling support holes	Contact your dealer for information on mounting the projector on a ceiling.	-

Note:

- When installing, ensure that you use only UL Listed ceiling mounts.
- For ceiling installations, use approved mounting hardware and M6 screws with a maximum screw depth of 10 mm (0.39 inch).
- The construction of the ceiling mount must be of a suitable shape and strength. The ceiling mount load capacity must exceed the weight of the installed equipment, and as an additional precaution be capable of withstanding three times the weight of the equipment (not less than 71.4 kg) over a period of 60 seconds.

Remote Control Parts

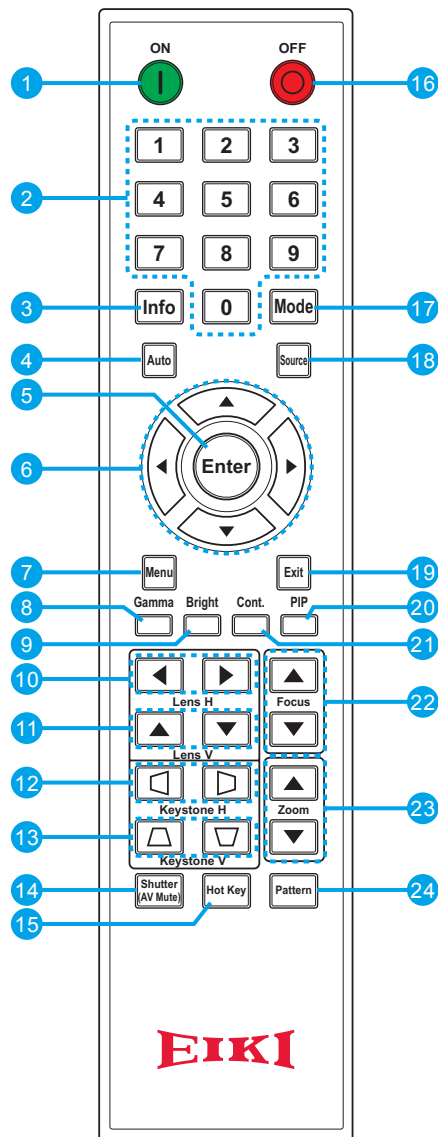

Important:

1. Avoid using the projector with bright fluorescent lighting turned on. Certain high-frequency fluorescent lights can disrupt remote control operation.
2. Be sure nothing obstructs the path between the remote control and the projector. If the path between the remote control and the projector is obstructed, you can bounce the signal off certain reflective surfaces such as projector screens.
3. The buttons and keys on the projector have the same functions as the corresponding buttons on the remote control. This owner's manual describes the functions based on the remote control.

Note:

Complies with FDA performance standards for laser products except for deviations pursuant to Laser Notice No. 50, dated June 24, 2007.

ITEM	LABEL	DESCRIPTION	SEE PAGE
1	Power on	Turn projector ON.	12
2	Number Keys	Enter a number (such as PIN code) or source hotkey. Source Hotkey Key: 1: VGA 2: HDMI 3: DVI-D 4: HDBaseT	-
3	Info	Display source image information.	-
4	Auto	Automatically optimize image.	-
5	Enter	<ul style="list-style-type: none"> Select a highlighted menu item. Change or accept a value. 	21
6	Arrow Keys	<ul style="list-style-type: none"> Adjust a setting UP or DOWN. Navigate within a menu. 	21
7	Menu	Display menus.	21
8	Gamma	Adjust mid-range levels.	-
9	Bright	Adjust amount of light in the image.	-
10	Lens H	Adjust the position of the image horizontally.	-
11	Lens V	Adjust the position of the image vertically.	-
12	Keystone H	Adjust the horizontal keystone.	14
13	Keystone V	Adjust the vertical keystone.	14
14	Shutter (AV Mute)	Display or blank the video image.	-
15	Hot Key	Select your preset keys quickly.	-
16	OFF	Turn projector OFF.	12
17	Mode	Select the preset display mode.	-
18	Source	Select an input for the main or PIP/PBP image.	-
19	Exit	Return to previous level or exit menus if at top level.	21
20	PIP	Turn PIP/PBP ON/OFF.	-
21	Cont.	Adjust difference between dark and light.	-
22	Focus	Adjust focus to improve image clarity as desired.	14
23	Zoom	Adjust zoom to achieve a desired image size.	14
24	Pattern	Display a test pattern.	-



Caution:

Use of controls, adjustments or performance of procedures other than those specified herein may result in hazardous laser light exposure.

Remote Control Operating Range

The remote control uses infrared transmission to control the projector. It is not necessary to point the remote directly at the projector. Provided you are not holding the remote perpendicular to the sides or the rear of the projector, the remote will function well within a radius of about 10 meters (32.8 feet) and 30 degrees above or below the projector level. If the projector does not respond to the remote control, move a little closer.

Projector and Remote Control Buttons

The projector can be operated using the remote control or the buttons on the rear of the projector. All operations can be carried out with the remote control; however, the buttons on the projector are limited in use.

Remote Control Code

The ten different remote control modes (Code 0- Code 9) are assigned to this projector. Switching the remote control codes prevents interference from other remote controls when several projectors or video equipment next to each other are being operated at the same time. Change the remote control code for the projector first before changing that for the remote control. See “Projector Address” in the Communications Menu on page 43.

To change the code for the Remote Control:

Press and hold the **Mode** button and a number button (0-9) on the remote control for more than three seconds to switch among the codes.

Default setting: 0

To change the Projector Address for the projector:

Select a Projector Address in the Setup Menu. (SETUP → Communications → Projector Address)

Inserting the Remote Control Batteries

1. Remove the battery compartment cover as shown in the illustration.

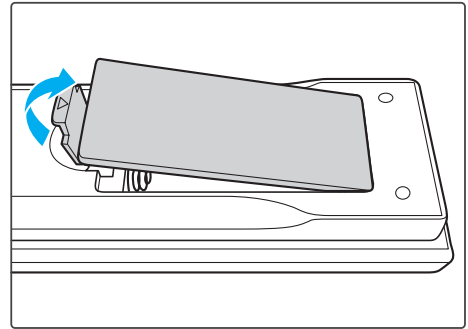

2. Insert the batteries with correct polarity (+/-) as shown inside the battery compartment.

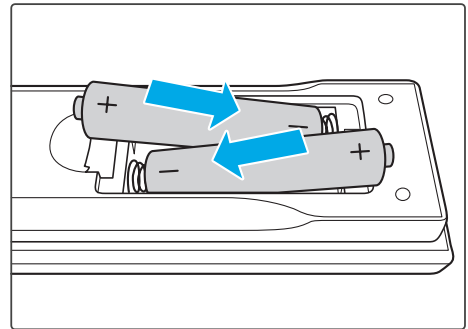

3. Replace the cover.

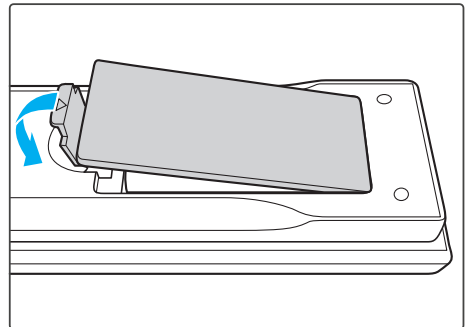

Caution:



- Only use AAA batteries (Alkaline batteries are recommended).
- Dispose of used batteries according to local ordinance regulations.
- Remove the batteries when not using the projector for prolonged periods.

Installing the Projection Lens

Before setting up the projector, install the projection lens on the projector.

Important:

- Before installation, check where the projector is used and prepare a suitable lens.
- For details, contact the sales dealer where you purchased the projector.

1. Press “” on the built-in keypad or press “” on the remote control twice to turn off the projector.
2. Rotate the lens cap counter-clockwise. Then remove the lens cap.

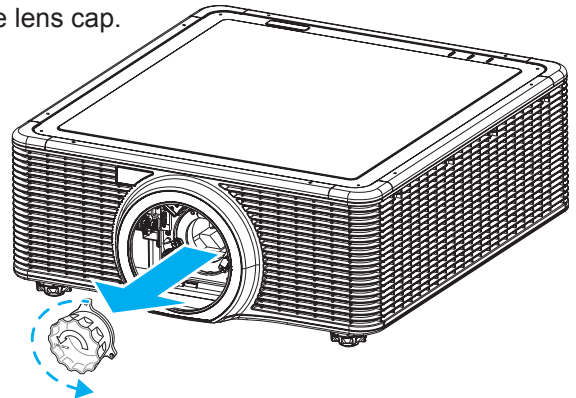

3. Remove both lens caps (front and back) on the lens.

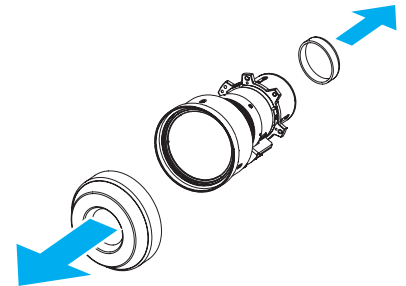

4. With the label “TOP” on the lens assembly facing up, install the assembly into the lens mount.

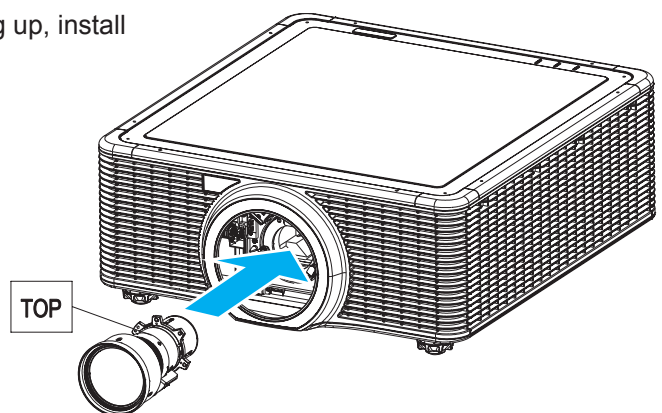

5. Rotate the lens clockwise to lock the lens in place.

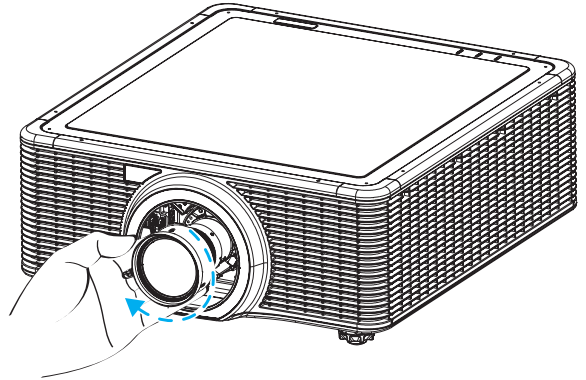

6. Firmly install the lens cover onto the lens.

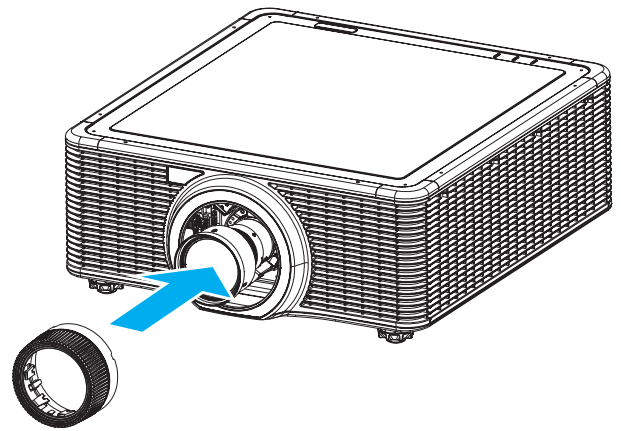

Starting and Shutting down the Projector

Turn the Projector On

1. Connect the power cord to the projector. Then connect the other end to a wall outlet. The Power button on the built in keypad is illuminated.

Important:

Make sure that the Power switch is in the ON position.

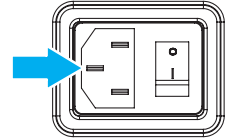

2. Turn on the connected devices.

3. Turn on the projector by pressing “**I**” on the remote control or press “**⏻**” on the built-in keypad. The Status LED is Orange with a long blink. The projector splash screen displays and connected devices are detected.



4. If more than one input device is connected, press the **Source** key on the remote control to select an input source (VGA, HDMI, HDBaseT, or DVI).
5. The projector detects the source you selected and displays the image.

Turn the Projector Off

1. Press “**⏻**” on the built-in keypad or press “**⏻**” on the remote control to turn off the projector. A warning message will appear on the displayed image.
2. Press “**⏻**” on the built-in keypad or press “**⏻**” on the remote control again to confirm your selection. If you do not press “**⏻**” or “**⏻**” again, the warning message will disappear after 10 seconds.

Caution:

Do not unplug the power cord until all of fans are stop—indicating the projector has cooled down.

Adjusting the Projector Level

Take note of the following when setting up the projector:

- The projector table or stand should be level and sturdy.
- Position the projector so that it is perpendicular to the screen.
- Ensure the cables are in a safe location. You could trip over them.

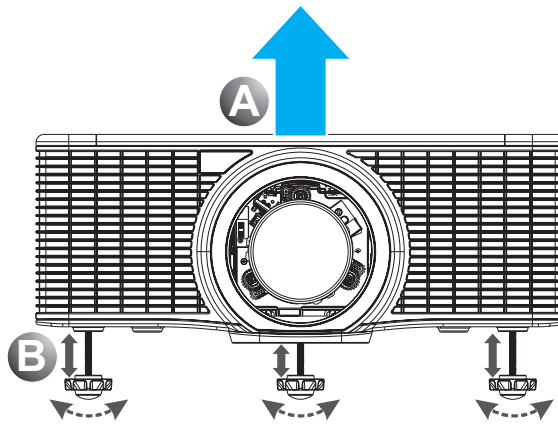

1. To raise the level of the projector, lift the projector **A**.
2. Locate the adjustable foot you wish to modify on the underside of the projector.
3. Rotate the adjustable foot clockwise to raise the projector or counter-clockwise to lower it. Repeat with the remaining feet as necessary **B**.

Adjusting the Zoom, Focus, and Keystone

1. Use the **Zoom** button to resize the projected image and screen size **B**.

2. Use the **Focus** button to sharpen the projected image **A**.

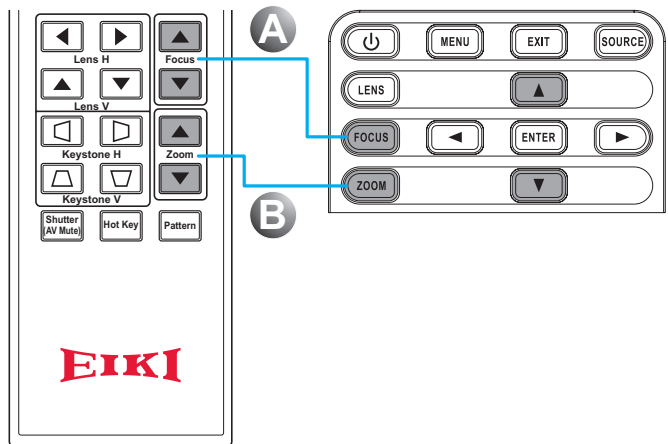

3. Use the **Keystone H** buttons (on the remote control) to adjust the keystone horizontally and make a squarer image. Use the **Keystone V** buttons (on the remote control) to adjust keystone vertically and make a squarer image.

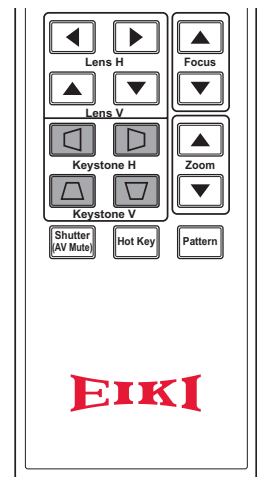

Using the Lens Shift Adjustment

The projection lens can be moved up, down, right, and left with the motor-driven lens shift function. This function makes the positioning of images easy on the screen. Lens shift is generally expressed as a percentage of the image height or width, see below illustration.

Vertical / Horizontal Lens Shift

Vertical Image Offset: 0% Offset (WUXGA)

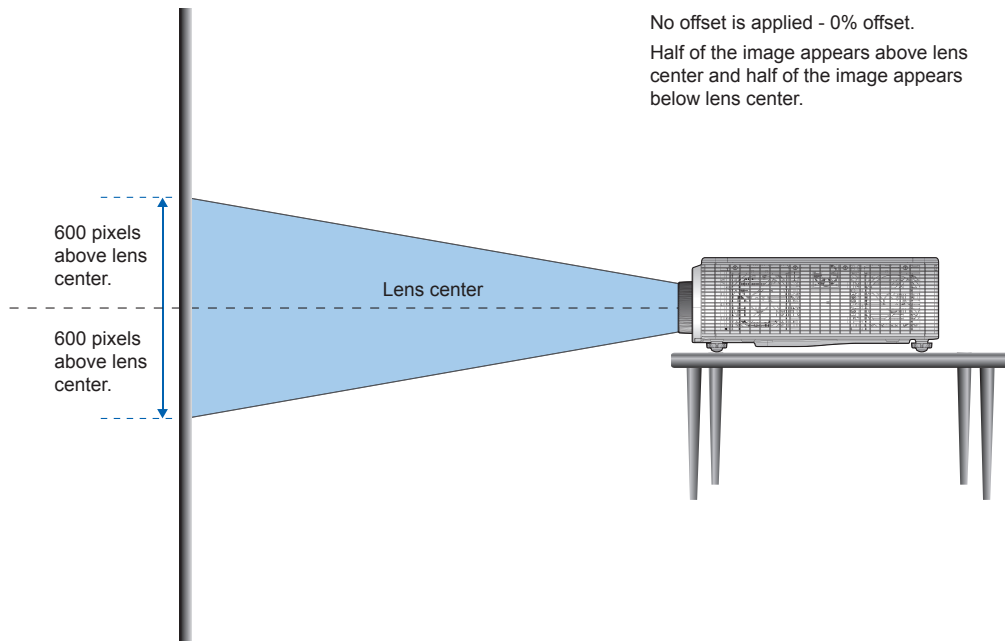

Vertical Image Offset: 50% Offset (WUXGA)

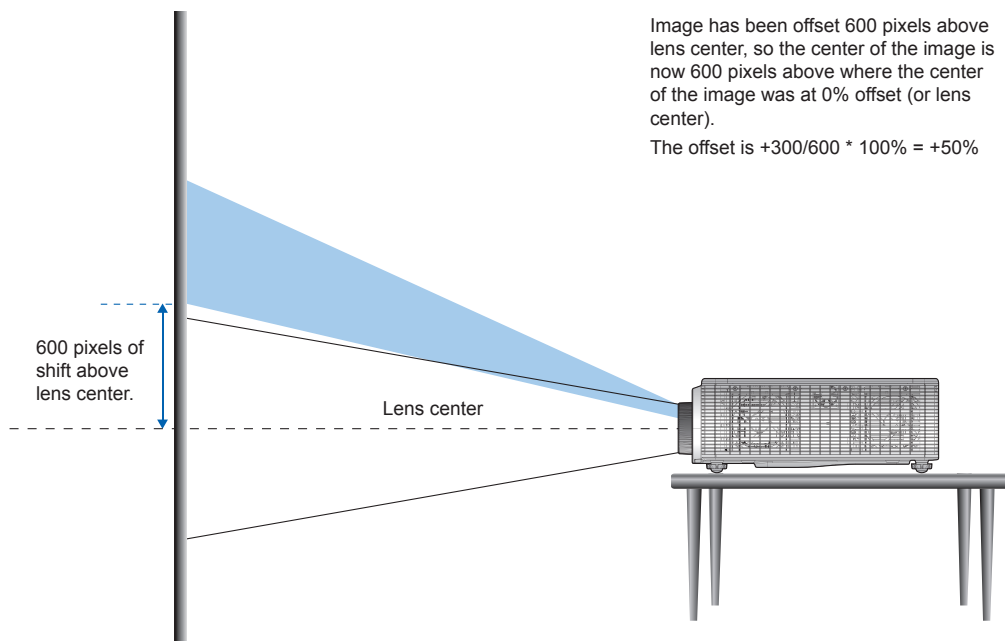

Vertical Image Offset: -50% Offset (WUXGA)

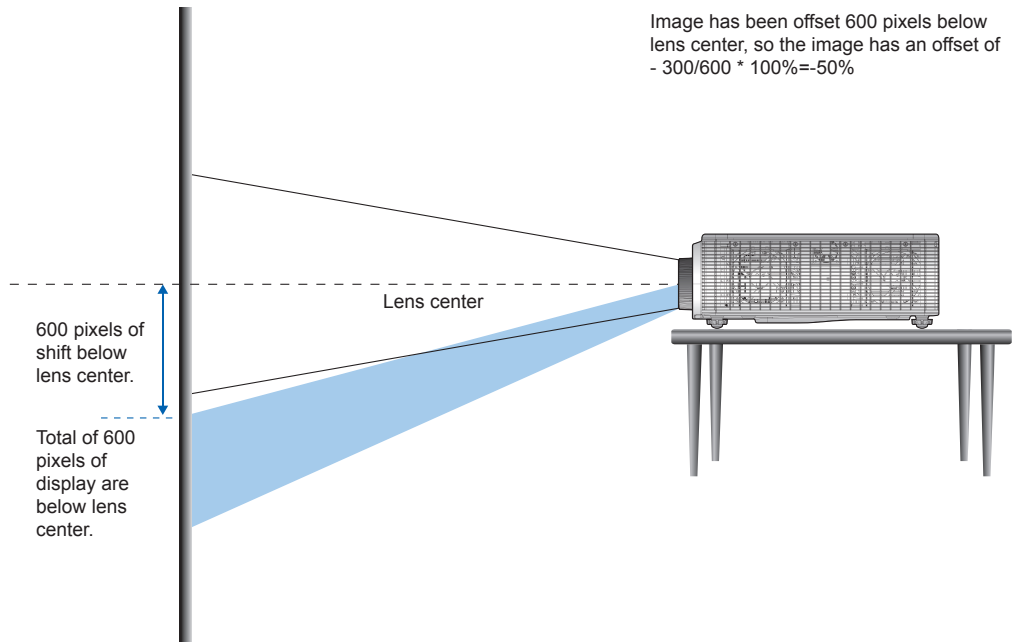

Horizontal Image Offset: +/-15% Offset (WUXGA)

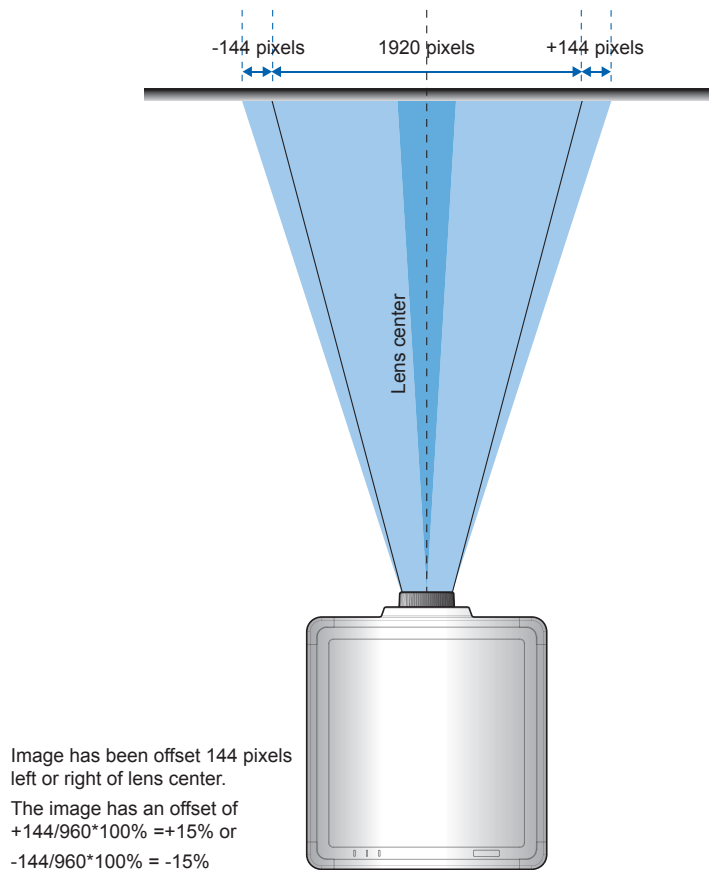

Optional Lenses and Projection Size

Projection Lens

The complete projection lens series as below table.

ITEM	LENS TYPE														
Lens Model Name	A16 (AH-A25010)	A15 (AH-A22010A)		A01 (AH-A22020)		A02 (AH-A22030)		A05 (AH-A22040)		A06 (AH-A22050)		A03 (AH-A21010)		A13 (AH-A23010)	
Focal Length (f)	9.49-9.55	11.11~14.06		14.03~17.96		18.07~22.59		18.07~22.59		18.07~22.59		22.56~42.87		42.60~80.90	
F number	2.4	2.30~2.53		2.30~2.57		2.00~2.32		2.00~2.32		2.00~2.32		2.30~3.39		2.30~2.47	
Focus spec (MTF)	67 lp/mm	67 lp/mm		67 lp/mm		47 lp/mm		67 lp/mm		67 lp/mm		67 lp/mm		67 lp/mm	
Zoom Range (Ratio)	no zoom	1.26X		1.28X		1.25X		1.25X		1.25X		1.9X		1.9X	
Zoom & Focus Adjustment	Motorized														
Throw Ratio	0.361 (120")	0.75~0.95		0.95~1.22		1.22~1.53		1.22~1.53		1.22~1.52		1.52~2.92		2.90~5.50	
Throw Distance	0.93-2.62m	0.81~6.13m		1.02~7.88m		1.31~9.89m		1.31~9.89m		1.31~9.89m		1.64~18.87m		3.12~35.54m	
Projection Image Size	120"~350"	50~300"													
Brightness (%)	76.5%	93% (Wide)	83% (Tele)	85% (Wide)	76% (Tele)	100% (Wide)	87% (Tele)	100% (Wide)	87% (Tele)	100% (Wide)	87% (Tele)	85% (Wide)	52% (Tele)	93% (Wide)	71% (Tele)
Motorized Lens Shift (Lens shift range based on screen width and height)	Horizontal: ±15% Vertical: ±50%														
	Projection Lens: A01, A03, A13														
	PLATFORM	H		V		△H		△V							
	0.65" WXGA	30%		100%		30%		100%							
	Projection Lens: A02, A05														
	PLATFORM	H		V		△H		△V							
	0.65" WXGA	30%		100%		15%		70%							
	Projection Lens: A06														
	PLATFORM	H		V		△H		△V							
	0.65" WXGA	30%		100%		30%		100%							
Projection Lens: A15															
PLATFORM	H		V		△H		△V								
0.65" WXGA	30%		100%		20%		70%								

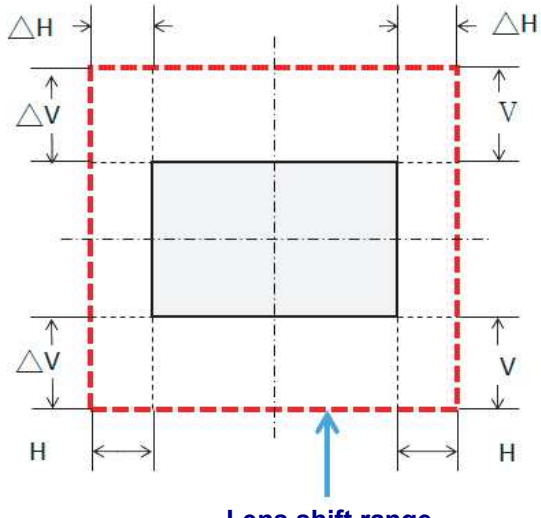
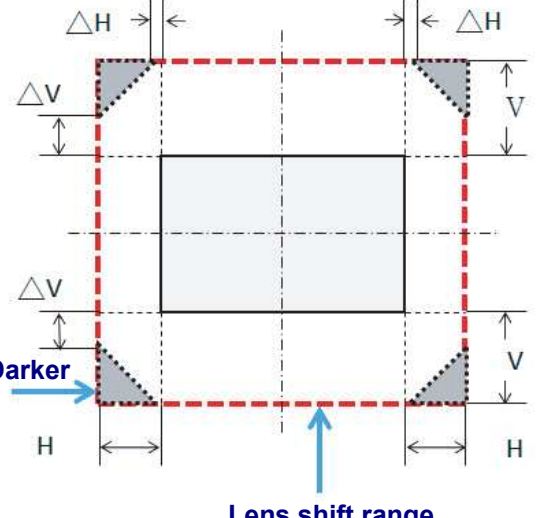
<p>Motorized Lens Shift (Lens shift range based on screen width and height)</p>		<p>A01/A03/A13 lens shift range:</p>  <p>A02/A05/A06/A15 lens shift range:</p>  <p>When the lens is shifted beyond the described range of operation, the screen edges may become darker or the images may become out of focus.</p>
--	--	---

Other Optional Parts:

PART NUMBER	ITEM
AH-B34020	WiFi Dongle
AH-B34030	Wired Remote Cable

Projection Size v.s Throw Distance

PLATFORM			EK-625U WUXGA (16:10)														
DMD			0.67"														
PROJECTION LENS			A16	A15		A01		A02		A05		A06		A03		A13	
THROW RATIO			0.361 (120")	0.75-0.95		0.95-1.22		1.22-1.53		1.22-1.53		1.22-1.52		1.53-2.92		2.90-5.50	
ZOOM RATIO			NA	1.26X		1.28X		1.25X		1.25X		1.25X		1.9X		1.9X	
THROW DISTANCE			0.93- 2.62M	0.81-6.13M		1.02~7.88M		1.31~9.89M		1.31~9.89M		1.32~9.82M		1.64~18.87M		3.12~35.54M	
PROJECTION SCREEN SIZE			PROJECTION DISTANCE (M)														
THROW RATIO			0.361	0.75	0.95	0.95	1.22	1.22	1.53	1.22	1.53	1.22	1.52	1.53	2.92	2.9	5.5
DIAGONAL (INCH)	HEIGHT (M)	WIDTH (M)		MIN (M)	MAX (M)	MIN (M)	MAX (M)	MIN (M)	MAX (M)	MIN (M)	MAX (M)	MIN (M)	MAX (M)	MIN (M)	MAX (M)	MIN (M)	MAX (M)
50	0.67	1.08	NA	0.81	1.03	1.02	1.32	1.31	1.65	1.31	1.65	1.32	1.64	1.65	3.14	3.13	5.94
60	0.81	1.29	NA	0.97	1.23	1.23	1.57	1.58	1.98	1.58	1.98	1.57	1.96	1.98	3.77	3.74	7.1
70	0.94	1.51	NA	1.13	1.43	1.43	1.84	1.84	2.31	1.84	2.31	1.84	2.30	2.31	4.4	4.38	8.31
80	1.08	1.72	NA	1.29	1.63	1.64	2.1	2.1	2.64	2.1	2.64	2.10	2.61	2.64	5.03	4.99	9.46
90	1.21	1.94	NA	1.46	1.84	1.84	2.36	2.36	2.97	2.36	2.97	2.37	2.95	2.97	5.66	5.63	10.67
100	1.35	2.15	NA	1.61	2.04	2.05	2.63	2.63	3.3	2.63	3.3	2.62	3.27	3.3	6.29	6.24	11.83
110	1.48	2.37	NA	1.78	2.25	2.25	2.89	2.89	3.62	2.89	3.62	2.89	3.60	3.62	6.92	6.87	13.04
120	1.62	2.58	0.96	1.94	2.45	2.46	3.15	3.15	3.95	3.15	3.95	3.15	3.92	3.95	7.55	7.48	14.19
130	1.75	2.8	1.04	2.1	2.66	2.66	3.42	3.42	4.28	3.42	4.28	3.42	4.26	4.28	8.18	8.12	15.4
140	1.88	3.02	1.11	2.27	2.87	2.86	3.68	3.68	4.61	3.68	4.61	3.68	4.59	4.61	8.8	8.76	16.61
150	2.02	3.23	1.18	2.42	3.07	3.07	3.94	3.94	4.94	3.94	4.94	3.94	4.91	4.94	9.43	9.37	17.77
160	2.15	3.45	1.26	2.59	3.28	3.27	4.2	4.2	5.27	4.2	5.27	4.21	5.24	5.27	10.06	10.01	18.98
170	2.29	3.66	1.33	2.75	3.48	3.48	4.47	4.47	5.6	4.47	5.6	4.47	5.56	5.6	10.69	10.61	20.13
180	2.42	3.88	1.40	2.91	3.69	3.68	4.73	4.73	5.93	4.73	5.93	4.73	5.90	5.93	11.32	11.25	21.34
190	2.56	4.09	1.47	3.07	3.89	3.89	4.99	4.99	6.26	4.99	6.26	4.99	6.22	6.26	11.95	11.86	22.5
200	2.69	4.31	1.55	3.23	4.09	4.09	5.25	5.25	6.59	5.25	6.59	5.26	6.55	6.59	12.58	12.5	23.71
250	3.37	5.38	1.91	4.04	5.11	5.11	6.57	6.57	8.24	6.57	8.24	6.56	8.18	8.24	15.72	15.6	29.59
300	4.04	6.46	2.28	4.85	6.13	6.14	7.88	7.88	9.89	7.88	9.89	7.88	9.82	9.89	18.87	18.73	35.53

ON-SCREEN DISPLAY (OSD) MENU SETTINGS

OSD Menu Controls

The projector has an OSD that lets you make image adjustments and change various settings.

Navigating the OSD

You can use the remote control cursor buttons or the projector keypad to navigate and make changes to the OSD.

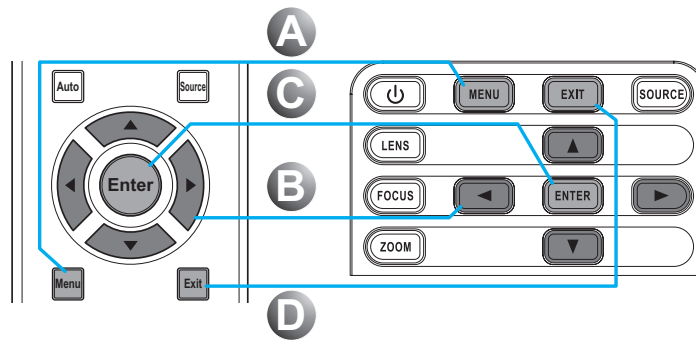

1. To enter the OSD, press the **Menu** button **A**.
2. Use the arrow keys (**▲▼◀▶**) to navigate within the menu and adjust a setting up or down **B**.
3. Press the **Enter** button to enter the submenu or confirm the selection/setting **C**.
4. Press the **Exit** button to return to the previous menu or exit menus if at top level **D**.

PICTURE		PICTURE
	Display Mode	Presentation
	Brightness	50
OUTPUT	Contrast	50
	Sharpness	2
SETUP	Color	50
	Tint	50
	Phase	50
OPTION	Frequency	50
	Horz Position	50
	Vert Position	50

Caution:

Depending on the video source, not all items in the OSD are available. Items that are not available cannot be accessed and are grayed out.

Setting the OSD Language

Set the OSD language to your preference before continuing.

1. Press the **Menu** button.

PICTURE		PICTURE	
	Display Mode		Presentation
	Brightness		50
OUTPUT	Contrast		50
	Sharpness		2
SETUP	Color		50
	Tint		50
	Phase		50
OPTION	Frequency		50
	Horz Position		50
	Vert Position		50

2. Use the arrow keys (▲▼) to select **SETUP** and press the **Enter** button to enter the **SETUP** menu.

PICTURE		SETUP	
	Language		English
	Ceiling Mount		Auto
OUTPUT	Rear Projection		Off
	Lens Function		
SETUP	Menu Preferences		
	Keypad LED Settings		On
	PIN		
OPTION	Communications		

3. Use the arrow keys (▲▼) to select **Language** and press the **Enter** button to enter its submenu.
4. Use the arrow keys (▲▼◀▶) to select the desired language and press the **Enter** button to confirm.
5. Press the **Exit** button several times to exit the menu.

Language
English
Français
Español
Deutsch
Italiano
Русский
简体中文
日本語
한국어
Português
Indonesian
Nederlands
العربية

OSD Menu Overview

Use the following illustration to quickly find a setting or determine the range for a setting.

MAIN MENU	SUB MENU / SETTINGS			DEFAULT	
PICTURE	Display Mode	Presentation		By source set	
		Video			
		Bright			
		REC709			
		DICOM SIM			
		2D High Speed			
		3D			
		Blending			
		User			
		Save to User			
	Brightness	0 ~ 100		50	
	Contrast	0 ~ 100		50	
	Sharpness	0 ~ 4		2	
	Color	0 ~ 100		50	
	Tint	0 ~ 100		50	
	Phase	0 ~ 100		50	
	Frequency	0 ~ 100		50	
	Horz Position	0 ~ 100		50	
	Vert Position	0 ~ 100		50	
	3D Display	3D Enable	Auto		Auto
			Frame Packing		
Side by Side					
Top and Bottom					
Frame Sequential					
3D Invert		Off		Off	
		On			
DLP Link		Off		On	
		On			
HSG Adjustment		HSG Enable	Off		Off
	On				
	Auto Test Pattern	Off		On	
		On			
	Red H.	0 – 254		WX:140 WU:141	
	Red S.	0 – 254		WX:127 WU:127	
	Red G.	0 – 254		WX:107 WU:100	
Green H.	0 – 254		WX:98 WU:103		
Green S.	0 – 254		WX:121 WU:122		

MAIN MENU	SUB MENU / SETTINGS			DEFAULT	
PICTURE	HSG Adjustment	Green G.	0 – 254		WX:127 WU:127
		Blue H.	0 – 254		WX:127 WU:127
		Blue S.	0 – 254		WX:127 WU:127
		Blue G.	0 – 254		WX:127 WU:127
		Cyan H.	0 – 254		WX:127 WU:127
		Cyan S.	0 – 254		WX:127 WU:127
		Cyan G.	0 – 254		WX:127 WU:127
		Magenta H.	0 – 254		WX:127 WU:127
		Magenta S.	0 – 254		WX:127 WU:127
		Magenta G.	0 – 254		WX:127 WU:127
		Yellow H.	0 – 254		WX:127 WU:127
		Yellow S.	0 – 254		WX:127 WU:127
		Yellow G.	0 – 254		WX:127 WU:127
		White R Gain	0 – 254		WX:127 WU:127
		White G Gain	0 – 254		WX:127 WU:127
		White B Gain	0 – 254		WX:127 WU:127
		Reset to Default			
	Advanced	White Peaking	0 - 100		By source set
		Gamma	Video		By source set
			Film		
			Bright		
			CRT		
			DICOM		
			Gamma2.2		
		Color Temperature	Warmest		By source set
			Warm		
			Cool		
			Bright		
Color Space	RGB		Auto		
	REC709				
	REC601				
	RGB Video				
	Auto				

MAIN MENU	SUB MENU / SETTINGS			DEFAULT	
PICTURE	Advanced	Color Settings	Red Gain	0 ~ 100	50
			Green Gain	0 ~ 100	50
			Blue Gain	0 ~ 100	50
			Red Offset	0 ~ 100	50
			Green Offset	0 ~ 100	50
			Blue Offset	0 ~ 100	50
			Reset RGB Gain/ Offset		
		Color Enhancement	0 ~ 2		1
		Color Wheel Speed	2X		2X
			3X		
		Film Mode	Off		Off
			On		
		Extreme Black	Off		Off
			On		
DynamicBlack™	Off		Off		
	On				
OUTPUT	Aspect Ratio	Auto		Auto	
		4:3			
		16:9			
		16:10			
		Native			
	Overscan	Off		By source set	
		Zoom			
		Crop			
	H Digital Zoom	50% ~ 400%		100	
	V Digital Zoom	50% ~ 400%		100	
	H Digital Shift	0 ~ 100		50	
	V Digital Shift	0 ~ 100		50	
	Image Warping	PC Mode	Off		Off
			On		
		H Keystone	0 ~ 40		20
		V Keystone	0 ~ 40		20
		H Pincushion	0 ~ 100		50
		V Pincushion	0 ~ 100		50
		4-Corner	Top Left Horz Adjust	0 ~ 120 (pixel)	0
			Top Left Vert Adjust	0 ~ 80	0
Top Right Horz Adjust			0 ~ 120	0	
Top Right Vert Adjust			0 ~ 80	0	
Bottom Left Horz Adjust			0 ~ 120	0	
Bottom Left Vert Adjust			0 ~ 80	0	
Bottom Right Horz Adjust			0 ~ 120	0	

MAIN MENU	SUB MENU / SETTINGS				DEFAULT	
OUTPUT	Image Warping	4-Corner	Bottom Right Vert Adjust	0 ~ 80	0	
	PIP/PBP	PIP/PBP Enable	Off		Off	
			On			
		Main Source	VGA		VGA	
			HDMI			
			DVI-D			
			HDBaseT			
			LAN			
		Sub Source	VGA			
			HDMI			
			DVI-D			
			HDBaseT			
			LAN			
		Swap				
		Size	Small		Large	
			Medium			
			Large			
		Main Layout	PBP, Main Left		PBP, Main Left	
	PBP, Main Top					
	PBP, Main Right					
PBP, Main Bottom						
PIP-Bottom Right						
PIP-Bottom Left						
PIP-Top Left						
PIP-Top Right						
SETUP	Language	English		English		
		French				
		Spanish				
		German				
		Italian				
		Russian				
		Chinese Simplified				
		Japanese				
		Korean				
		Portuguese				
		Indonesian				
		Dutch				
		Arabic				
	Ceiling Mount	Off		Auto		
On						
Auto						

MAIN MENU	SUB MENU / SETTINGS			DEFAULT	
SETUP	Rear Projection	Off		Off	
		On			
	Lens Function	Focus		Focus in - motor stop	
				Focus in - motor go step	
				Focus in - motor run	
				Focus out - motor stop	
				Focus out - motor go step	
				Focus out - motor run	
		Zoom		Zoom in - motor stop	
				Zoom in - motor go step	
				Zoom in - motor run	
				Zoom out - motor stop	
				Zoom out - motor go step	
				Zoom out - motor run	
		Lens Shift		Left shift up - motor stop	
				Left shift up - motor go step	
				Left shift up - motor run	
				Left shift down - motor stop	
				Left shift down - motor go step	
				Left shift down - motor run	
				Left shift right - motor stop	
				Left shift right - motor go step	
				Left shift right - motor run	
				Left shift left - motor stop	
				Left shift left - motor go step	
				Left shift left - motor run	
			Lens Calibration	Yes/No (Dialog box)	
		Lens Lock	No		No
			Yes		
	Menu Preferences	Menu Transparency	0 ~ 9	0	
		Show Messages	Off	On	
	On				
	Keypad LED Settings	Off	On		
		On			
	PIN	PIN Protect	Off	Off	
			On		
Change PIN					

MAIN MENU	SUB MENU / SETTINGS			DEFAULT		
SETUP	Communications	LAN	DHCP	Off	by set	
				On		
				IP Address		by set
				Subnet Mask		by set
				Default Gateway		by set
				MAC Address		by set
			Apply			
		WLAN	Enable		by set	
			Start IP		by set	
			End IP		by set	
			Subnet Mask		by set	
			Default Gateway		by set	
			MAC Address		by set	
		Network	SSID		by set	
			Projector Name		by set	
			Restart Network			
		Serial Port Baud Rate	Network Factory Reset			
			9600		19200	
			14400			
			19200			
38400						
57600						
115200						
Serial Port Path	RS232		RS232			
	HDBaseT					
	Projector Address	0 - 9	0			
OPTION	Auto Source	Off		On		
		On				
	High Altitude	Off		Off		
		On				
	Test Pattern	Off		Off		
		Grid				
		Red				
		Green				
		Blue				
		Yellow				
		Magenta				
		Cyan				
		White				
		Black				

MAIN MENU	SUB MENU / SETTINGS			DEFAULT
OPTION	Background Color	Logo		Logo
		Blue		
		Black		
		White		
	Hot-Key settings	Blank Screen		Blank Screen
		Aspect Ratio		
		Freeze Screen		
		Overscan		
	Power Settings	Standby Power Mode	0.5W mode	Communication mode
			Communication mode	
		Direct Power On	Off	Off
			On	
		Auto Power Off	No	20 Mins
			5 Mins	
			10 Mins	
			15 Mins	
			20 Mins	
			25 Mins	
		Sleep Timer	No	No
			2 Hours	
			4 Hours	
	6 Hours			
	Light Source Settings	Light Source Mode	Constant Power	Constant Power
			Constant Luminance	
			Eco Mode	
		Constant Power Settings	0 – 99	99
		Constant Luminance Settings	0 – 99	80
	Light Sensor	Total Projector Hours		
		Light Sensor Calibration		
	Information	Calibrated?	(Display Yes/No)	
		Model Name		
		Serial Number		
		Native Resolution		
Firmware				
Main Source				
- Resolution				
- Signal Format				
- Pixel Clock				
- Horz Refresh				
- Vert Refresh				

MAIN MENU	SUB MENU / SETTINGS			DEFAULT
OPTION	Information	Sub Source		
		- Resolution		
		- Signal Format		
		- Pixel Clock		
		- Horz Refresh		
		- Vert Refresh		
		Light Source Mode		
		Total Projector Hours		
		Standby Power Mode		
		IP Address		
		DHCP		
	Factory Reset	Yes/No (Dialog box)		
	Service			

Picture Menu

Press the **Menu** button to open the OSD menu. Press the arrow keys (▲▼) to select **PICTURE** and press the **Enter** button to enter the **PICTURE** menu. Press the arrow keys (▲▼) to select the menu option and press the **Enter** button to enter its submenu. Press the arrow keys (▲▼◀▶) to select or adjust the desired settings and press the **Enter** button to confirm.

PICTURE		PICTURE	
	Display Mode	Presentation	
	Brightness	50	
OUTPUT	Contrast	50	
	Sharpness	2	
SETUP	Color	50	
	Tint	50	
	Phase	50	
OPTION	Frequency	50	
	Horz Position	50	
	Vert Position	50	

ITEM	DESCRIPTION
Display Mode	Optimize the projector for displaying images under certain conditions, such as Presentation, Video, Bright, REC709, DICOM SIM, 2D High Speed, 3D, Blending, and user-definable preset.
Brightness	Adjust the intensity of the image.
Contrast	Adjust the degree of difference between the lightest and darkest parts of the picture and change the amount of black and white in the image.
Sharpness	Select the edge clarity of the image.
Color	Adjust a video image from black and white to fully saturated color. The color setting applies to video sources only.
Tint	Adjust the red-green color balance in the image of video images. The tint setting applies to video sources only.
Phase	Analog signals only. Adjust pixel phase when the image still shows shimmer or noise after pixel tracking is optimized. Pixel phase can adjust the phase of the pixel-sampling clock relative to the incoming signal.
Frequency	Analog signals only. Steady flickering or several soft vertical stripes or bands across the entire image indicates poor frequency. Proper frequency ensures that the image quality is consistent across the screen, the aspect ratio is maintained, and that the pixel phase can be optimized.
Horz Position	Move the image right or left within the area of available pixels.
Vert Position	Move the image up or down within the area of available pixels.
3D Display	Configure the 3D display settings. See "3D Display Menu" on page 32.
HSG Adjustment	Configure the color management settings. See "HSG Adjustment Menu" on page 33.
Advanced	Configure the advanced image settings. See "Advanced Menu" on page 34.

3D Display Menu

Press the **Menu** button to open the OSD menu. Press the arrow keys (▲▼) to select **PICTURE** and press the **Enter** button to enter the **PICTURE** menu. Press the arrow keys (▲▼) to select **3D Display** and press the **Enter** button to enter the **3D Display** menu. Press the arrow keys (▲▼) to select the menu option and press the **Enter** button to enter its submenu. Press the arrow keys (▲▼◀▶) to select or adjust the desired settings and press the **Enter** button to confirm.

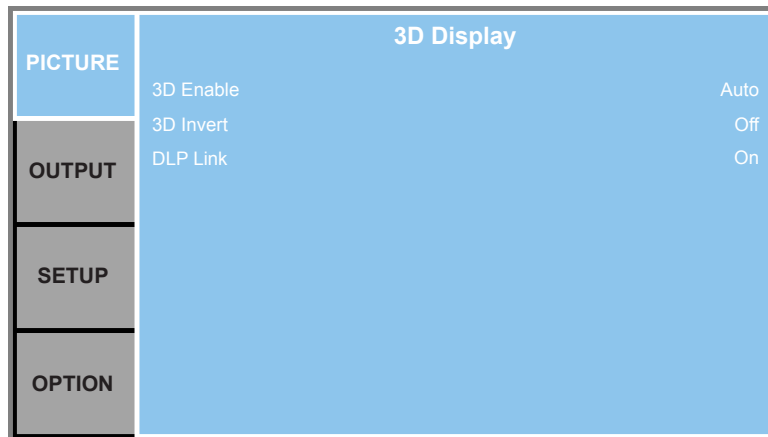

ITEM	DESCRIPTION
3D Enable	Set 3D format. Supports Mandatory 3D formats and frame sequential 3D@120Hz.
3D Invert	Invert 3D sync signal for the application of using single projector.
DLP Link	Select 3D Sync source: <ul style="list-style-type: none"> • On: 3D Sync type is DLP link. • Off: 3D Sync source is from the 3D Sync OUT port.

HSG Adjustment Menu

Press the **Menu** button to open the OSD menu. Press the arrow keys (▲▼) to select **PICTURE** and press the **Enter** button to enter the **PICTURE** menu. Press the arrow keys (▲▼) to select **HSG Adjustment** and press the **Enter** button to enter the **HSG Adjustment** menu. Press the arrow keys (▲▼) to select the menu option and press the **Enter** button to enter its submenu. Press the arrow keys (▲▼◀▶) to select or adjust the desired settings and press the **Enter** button to confirm.

PICTURE		HSG Adjustment	
		HSG Enable	On
		Auto Test Pattern	On
OUTPUT		Red H.	254
		Red S.	0
		Red G.	0
SETUP		Green H.	254
		Green S.	0
		Green G.	0
OPTION		Blue H.	254
		Blue S.	0

ITEM	DESCRIPTION
HSG Enable	Enable/Disable the HSG adjustment function.
Auto Test Pattern	Set to "On" to enable displaying a test pattern for the target color or set to "Off" to disable the auto test pattern.
Red H. / Green H. / Blue H. / Cyan H. / Magenta H. / Yellow H.	Adjust the hue of the red, green, blue, cyan, magenta, or yellow channel of the image.
Red S./ Green S./ Blue S./ Cyan S./ Magenta S./ Yellow S.	Adjust the saturation of the red, green, blue, cyan, magenta, or yellow channel of the image.
Red G. / Green G. / Blue G. / Cyan G. / Magenta G. / Yellow G.	Adjust the gain of the red, green, blue, cyan, magenta, or yellow channel of the image.
White R Gain / White G Gain / White B Gain	Adjust the white balance of the red, green, or blue channel of the image.
Reset to Default	Reset the hue, saturation, gain, and white balance adjustments to the factory defaults.

Advanced Menu

Press the **Menu** button to open the OSD menu. Press the arrow keys (▲▼) to select **PICTURE** and press the **Enter** button to enter the **PICTURE** menu. Press the arrow keys (▲▼) to select **Advanced** and press the **Enter** button to enter the **Advanced** menu. Press the arrow keys (▲▼) to select the menu option and press the **Enter** button to enter its submenu. Press the arrow keys (▲▼◀▶) to select or adjust the desired settings and press the **Enter** button to confirm.

Advanced	
PICTURE	White Peaking 100
	Gamma Bright
OUTPUT	Color Temperature Bright
	Color Space RGB
SETUP	Color Settings
	Color Enhancement 0
OPTION	Color Wheel Speed 2X
	Film Mode Off
	Extreme Black Off
	DynamicBlack™ Off

ITEM	DESCRIPTION
White Peaking	(Video source only) Increase the brightness of whites that are near 100%.
Gamma	Select the appropriate gamma from Video, Film, Bright, CRT, DICOM, and Gamma2.2.
Color Temperature	Change the intensity of the colors.
Color Space	Select a color space that has been specifically tuned for the input signal. Use only for analog signals and certain digital sources.
Color Settings	Adjust the gain of the red, green, or blue channel of the image. It will affect the black and white. Adjust the offset of the red, green, or blue channel of the image. It will affect the black and white. Reset RGB gain/offset to return the factory default settings for color adjustments.
Color Enhancement	The Color Enhancement control can improve the picture quality of pictures with a high saturation of color.
Color Wheel Speed	Higher speed will reduce the appearance of color artifacts seen by some people.
Film Mode	Control film mode detection and determine whether the original source of the input video was film or video.
Extreme Black	Analyze the current input image and calculate an offset value which is then added to the analog to digital converter black level value. This ensures optimum black level for each analog source.
DynamicBlack™	Enable or disable the dynamic black function. Enable this function raises the contrast ratio dynamically.

Output Menu

Press the **Menu** button to open the OSD menu. Press the arrow keys (▲▼) to select **OUTPUT** and press the **Enter** button to enter the **OUTPUT** menu. Press the arrow keys (▲▼) to select the menu option and press the **Enter** button to enter its submenu. Press the arrow keys (▲▼◀▶) to select or adjust the desired settings and press the **Enter** button to confirm.

PICTURE	OUTPUT	
	Aspect Ratio	Auto
	Overscan	Off
OUTPUT	H Digital Zoom	100
	V Digital Zoom	100
	H Digital Shift	50
	V Digital Shift	50
SETUP	Image Warping	
	PIP/PBP	
OPTION		

ITEM	DESCRIPTION
Aspect Ratio	Display an image with the detected size, or resize the image by maximizing either the height, width or both, or resize to the maximum size possible while keeping the original aspect ratio.
Overscan	Remove noise around the image. Overscan Zoom enlarges image 3% from original size. Overscan Crop cuts 3% of active pixels in four edges of original image.
H Digital Zoom	Change the size of projector's display area horizontally. If the display area has been resized by this setting, it can be moved by changing the H Digital Shift and V Digital Shift settings.
V Digital Zoom	Change the size of projector's display area vertically. If the display area has been resized by this setting, it can be moved by changing the H Digital Shift and V Digital Shift settings.
H Digital Shift	Move the display area horizontally if its size has been changed by the Digital Zoom setting.
V Digital Shift	Move the display area vertically if its size has been changed by the Digital Zoom setting.
Image Warping	Configure the image warping settings. See "Image Warping Menu" on page 36.
PIP/PBP	Configure the PIP/PBP settings. See "PIP/PBP Menu" on page 37.

Note:

When 16:9 Aspect Ratio is selected, the resolution of the input signal 1920x1200 or 1600x1200 will automatically be switched to 1600x900.

Image Warping Menu

Press the **Menu** button to open the OSD menu. Press the arrow keys (▲▼) to select **OUTPUT** and press the **Enter** button to enter the **OUTPUT** menu. Press the arrow keys (▲▼) to select **Image Warping** and press the **Enter** button to enter the **Image Warping** menu. Press the arrow keys (▲▼) to select the menu option and press the **Enter** button to enter its submenu. Press the arrow keys (▲▼◀▶) to select or adjust the desired settings and press the **Enter** button to confirm.

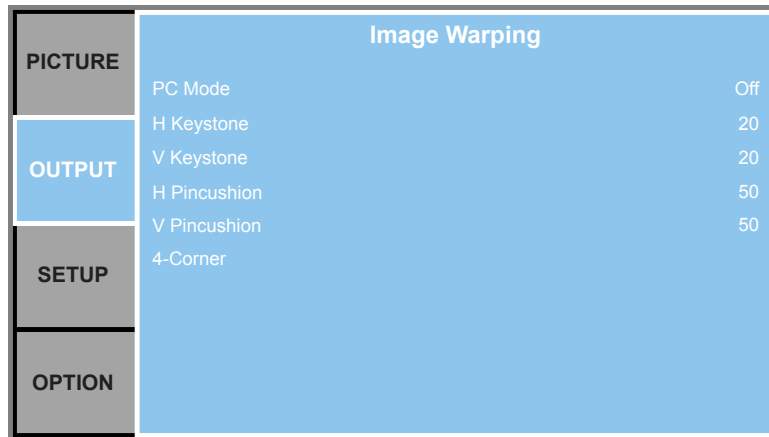

ITEM	DESCRIPTION
PC Mode	Enable PC software to control geometry.
H Keystone	Adjust the keystone horizontally and make a squarer image. Horizontal keystone is used to correct a keystone image shape in which the left and right borders of the image are unequal in length. This is intended for use with horizontally on-axis applications.
V Keystone	Adjust the keystone vertically and make a squarer image. Vertical keystone is used to correct a keystone image shape in which the top and bottom are slanted to one of the sides. This is intended when for use with vertically on-axis applications.
H Pincushion	Adjust the pincushion horizontally and make a more square image.
V Pincushion	Adjust the pincushion vertically and make a more square image.

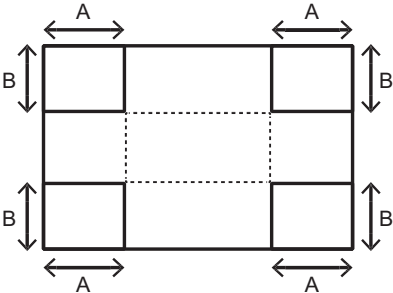
ITEM	DESCRIPTION
4-Corner	<p>Allow the image to be squeezed to fit an area defined by moving each of the four corners' x and y position.</p> 

PIP/PBP Menu

Press the **Menu** button to open the OSD menu. Press the arrow keys (▲▼) to select **OUTPUT** and press the **Enter** button to enter the **OUTPUT** menu. Press the arrow keys (▲▼) to select **PIP/PBP** and press the **Enter** button to enter the **PIP/PBP** menu. Press the arrow keys (▲▼) to select the menu option and press the **Enter** button to enter its submenu. Press the arrow keys (▲▼◀▶) to select or adjust the desired settings and press the **Enter** button to confirm.

















PIP/PBP	
PICTURE	PIP/PBP Enable On
OUTPUT	Main Source VGA
	Sub Source DVI-D
	Swap
	Size Large
SETUP	Main Layout PBP, Main Left
OPTION	

ITEM	DESCRIPTION
PIP/PBP Enable	Toggle between displaying two sources at once (Main and PIP/PBP images) or one source only.
Main Source	From the list of active inputs, select one to be used as the main image.
Sub Source	From the list of active inputs, select one to be used as the PIP/PBP.
Swap	Change the main image to PIP/PBP, and the PIP/PBP to main image. Swapping is available only when PIP/PBP is enabled.
Size	Select the PIP/PBP size. Available options: Small, Medium, or Large.
Main Layout	Set the location of the PIP/PBP image on the screen.

PIP/PBP layout and size table as described below.

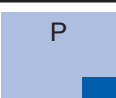
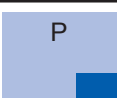
➤ P : indicates primary source region (lighter color).

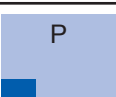
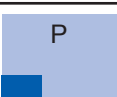
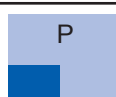
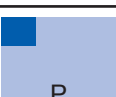
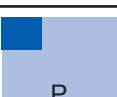
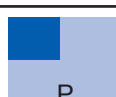
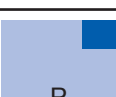
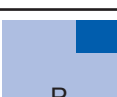
➤ * : Both source regions are the same size.

PIP/PBP MAIN LAYOUT	PIP/PBP SIZE		
	SMALL	MEDIUM	LARGE
PBP, Main Left			
PBP, Main Top			
PBP, Main Right			
PBP, Main Bottom			
PIP-Bottom Right			
PIP-Bottom Left			
PIP-Top Left			
PIP-Top Right			

Setup Menu

Press the **Menu** button to open the OSD menu. Press the arrow keys (▲▼) to select **SETUP** and press the **Enter** button to enter the **SETUP** menu. Press the arrow keys (▲▼) to select the menu option and press the **Enter** button to enter its submenu. Press the arrow keys (▲▼◀▶) to select or adjust the desired settings and press the **Enter** button to confirm.

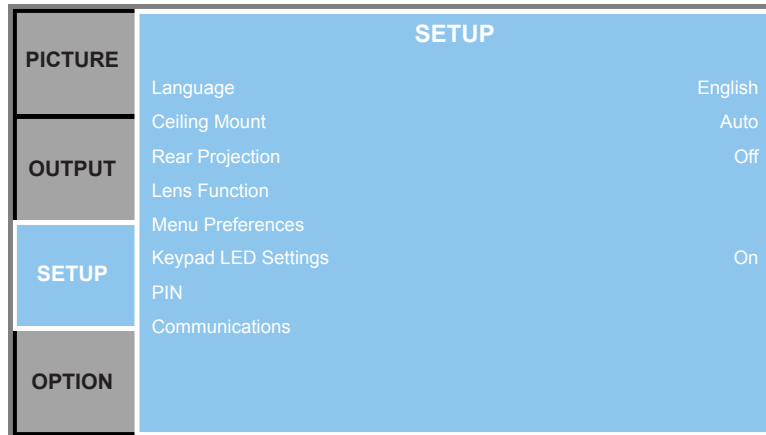

ITEM	DESCRIPTION
Language	This item allows you to select an available language for the OSD display.
Ceiling Mount	Turn the image upside down for ceiling-mounted projection.
Rear Projection	Reverse the image so you can project from behind a translucent screen.
Lens Function	Configure the lens function settings. See “Lens Function Menu” on page 40.
Menu Preferences	Configure the menu preferences settings. See “Menu Preferences Menu” on page 41.
Keypad LED Settings	Turn the backlight of keypad on/off.
PIN	Configure the PIN settings. See “PIN Menu” on page 42.
Communications	Configure the communications settings. See “Communications Menu” on page 43.

Lens Function Menu

Press the **Menu** button to open the OSD menu. Press the arrow keys (▲▼) to select **SETUP** and press the **Enter** button to enter the **SETUP** menu. Press the arrow keys (▲▼) to select **Lens Function** and press the **Enter** button to enter the **Lens Function** menu. Press the arrow keys (▲▼) to select the menu option and press the **Enter** button to enter its submenu. Press the arrow keys (▲▼◀▶) to select or adjust the desired settings and press the **Enter** button to confirm.

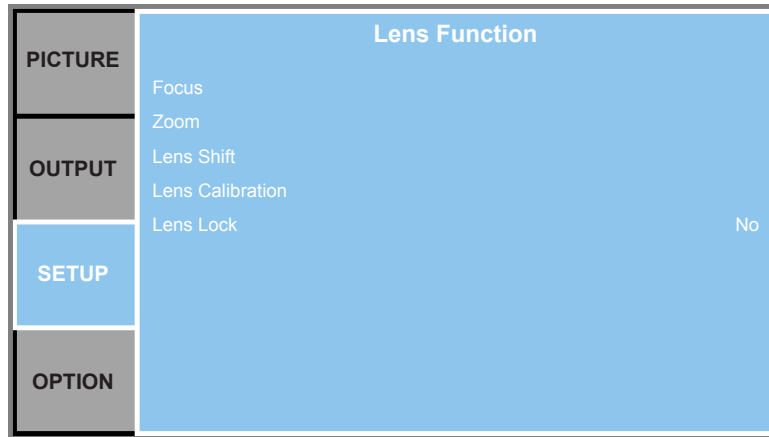

ITEM	DESCRIPTION
Focus	Adjust focus function on the projected image.
Zoom	Adjust zoom function on the projected image.
Lens Shift	Shift the projected image.
Lens Calibration	Perform calibration and return lens to the center position.
Lens Lock	Select this function to prevent all lens motors from moving. <ul style="list-style-type: none"> • Yes: Lens shift will be locked. • No: Lens shift can be used by user.

Menu Preferences Menu

Press the **Menu** button to open the OSD menu. Press the arrow keys (▲▼) to select **SETUP** and press the **Enter** button to enter the **SETUP** menu. Press the arrow keys (▲▼) to select **Menu Preferences** and press the **Enter** button to enter the **Menu Preferences** menu. Press the arrow keys (▲▼) to select the menu option and press the **Enter** button to enter its submenu. Press the arrow keys (▲▼◀▶) to select or adjust the desired settings and press the **Enter** button to confirm.

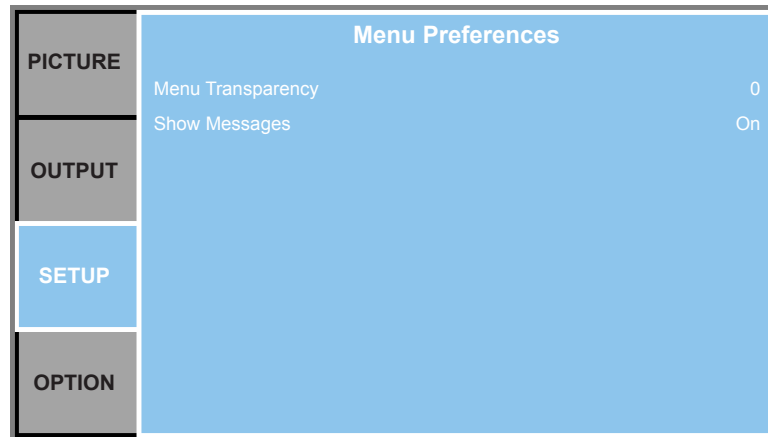

ITEM	DESCRIPTION
Menu Transparency	Change OSD menu background to be transparent.
Show Messages	Display status messages on the screen.

PIN Menu

Press the **Menu** button to open the OSD menu. Press the arrow keys (▲▼) to select **SETUP** and press the **Enter** button to enter the **SETUP** menu. Press the arrow keys (▲▼) to select **PIN** and press the **Enter** button to enter the **PIN** menu. Press the arrow keys (▲▼) to select the menu option and press the **Enter** button to enter its submenu. Press the arrow keys (▲▼◀▶) to select or adjust the desired settings and press the **Enter** button to confirm.

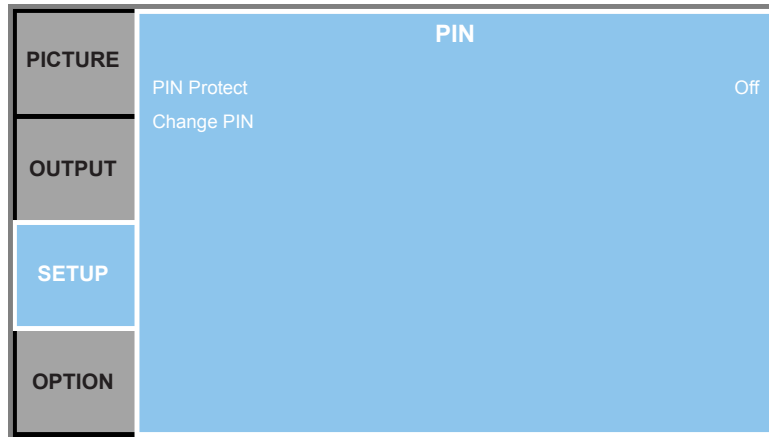

ITEM	DESCRIPTION
PIN Protect	The PIN (personal identification number) feature allows you to password protect your projector. Once you enable the PIN feature, you must enter the PIN before you can project an image. (PIN Default : 12345)
Change PIN	Change the PIN.

Communications Menu

Press the **Menu** button to open the OSD menu. Press the arrow keys (▲▼) to select **SETUP** and press the **Enter** button to enter the **SETUP** menu. Press the arrow keys (▲▼) to select **Communications** and press the **Enter** button to enter the **Communications** menu. Press the arrow keys (▲▼) to select the menu option and press the **Enter** button to enter its submenu. Press the arrow keys (▲▼◀▶) to select or adjust the desired settings and press the **Enter** button to confirm.

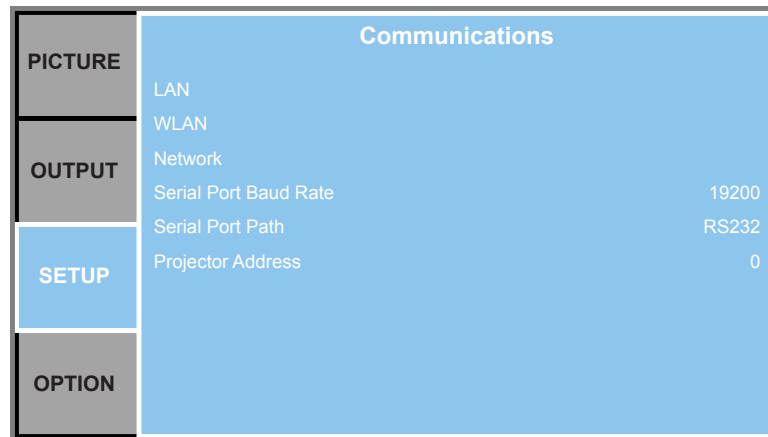

ITEM	DESCRIPTION
LAN	Configure the local area network (LAN) settings. <ul style="list-style-type: none"> • DHCP: Turn the DHCP ON/OFF. • IP Address: Assign Network IP Address. • Subnet Mask: Assign Network Subnet Mask. • Default Gateway: Assign Network Default Gateway. • MAC Address: Display the network MAC Address value. • Apply: Apply Network settings.
WLAN	Configure the wireless local area network (WLAN) settings. <ul style="list-style-type: none"> • Enable: Enable/Disable WLAN. • Start IP: Start of IP Address. • End IP: End of IP Address. • Subnet Mask: Assign Network Subnet Mask. • Default Gateway: Assign Network Default Gateway. • MAC Address: Display network MAC Address value. • SSID: Assign Network Service Set Identifier.
Network	Configure the general network settings. <ul style="list-style-type: none"> • Projector Name: Display the projector hostname for Network. • Restart Network: Restart the network. • Network Factory Reset: Perform factory reset on the network settings. The Projector Name and network configuration settings will be reset.
Serial Port Baud Rate	Select the serial port its baud rate.
Serial Port Path	Select the serial port path from either RS232 or HDBaseT.
Projector Address	Set the projector address. The projector will respond to IR remotes set either at the same address as the projector or to IR remotes set to address 0.

Option Menu

Press the **Menu** button to open the OSD menu. Press the arrow keys (▲▼) to select **OPTION** and press the **Enter** button to enter the **OPTION** menu. Press the arrow keys (▲▼) to select the menu option and press the **Enter** button to enter its submenu. Press the arrow keys (▲▼◀▶) to select or adjust the desired settings and press the **Enter** button to confirm.

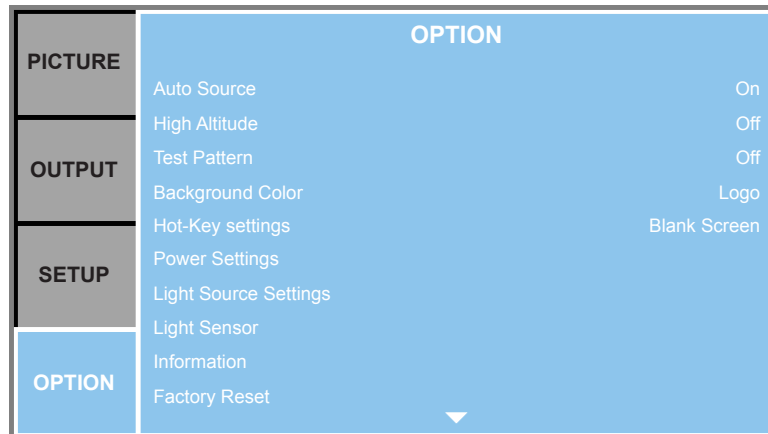

ITEM	DESCRIPTION
Auto Source	Select "On" to allow the projector to search for other signals if the current input signal is lost. When the setting is disabled, the projector will only search current input connection.
High Altitude	Set high altitude mode On/Off. When On, the fan will operate at high speed to ensure sufficient air flow for high altitudes.
Test Pattern	Choose the desired internal test pattern to display. Press the Pattern button to display next test pattern.
Background Color	Use this feature to display a "Logo", "Blue", "Black" or "White" screen when no signal is available.
Hot-Key settings	Assign a different function to the hot-key on the remote control by highlighting the function in the list and pressing the Enter button. Choose a function that does not already have a dedicated button, and assign the hot-key to that function, allowing you to quickly and easily use the chosen function.
Power Settings	Configure the power settings. See "Power Settings Menu" on page 45.
Light Source Settings	Configure the light source settings. See "Light Source Settings Menu" on page 46.
Light Sensor	Calibrate the Light Sensor for use with the Constant Luminance mode, which allows the projector to be set for constant brightness. If the Light Sensor has not been calibrated, Constant Luminance mode will be disabled.
Information	Display the projector information for source, resolution, and software version on the screen.
Factory Reset	Restore all settings to their default value. It will not reset network. WARNING: After resetting, lens calibration is necessary.
Service	For service only.

Power Settings Menu

Press the **Menu** button to open the OSD menu. Press the arrow keys (▲▼) to select **OPTION** and press the **Enter** button to enter the **OPTION** menu. Press the arrow keys (▲▼) to select **Power Settings** and press the **Enter** button to enter the **Power Settings** menu. Press the arrow keys (▲▼) to select the menu option and press the **Enter** button to enter its submenu. Press the arrow keys (▲▼◀▶) to select or adjust the desired settings and press the **Enter** button to confirm.

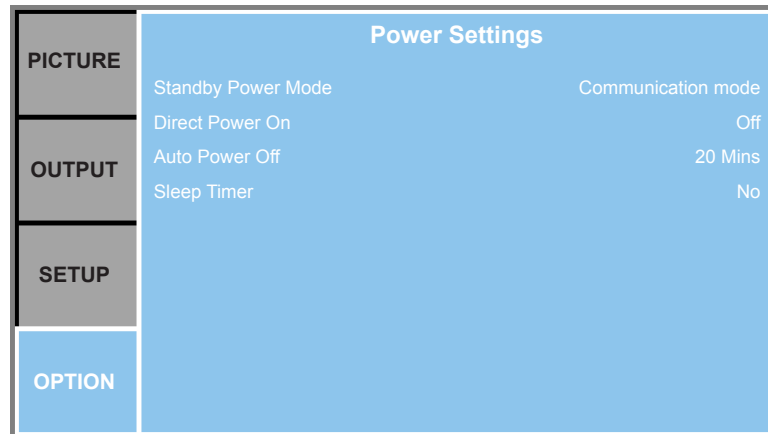

ITEM	DESCRIPTION
Standby Power Mode	Set the standby power mode. <ul style="list-style-type: none"> • 0.5W mode: The projector is in standby mode when connected to AC power. (<0.5W) • Communication mode: The projector could be controlled via the LAN terminal during power standby.
Direct Power On	The projector automatically turns on when electrical power is connected.
Auto Power Off	Automatically turns the projector off after no signals are detected for a preset number of minutes. If an active signal is received before the projector powers down, the image will be displayed.
Sleep Timer	This item allows the projector to automatically power off after it has been on for a specified amount of time.

Light Source Settings Menu

Press the **Menu** button to open the OSD menu. Press the arrow keys (▲▼) to select **OPTION** and press the **Enter** button to enter the **OPTION** menu. Press the arrow keys (▲▼) to select **Light Source Settings** and press the **Enter** button to enter the **Light Source Settings** menu. Press the arrow keys (▲▼) to select the menu option and press the **Enter** button to enter its submenu. Press the arrow keys (▲▼◀▶) to select or adjust the desired settings and press the **Enter** button to confirm.

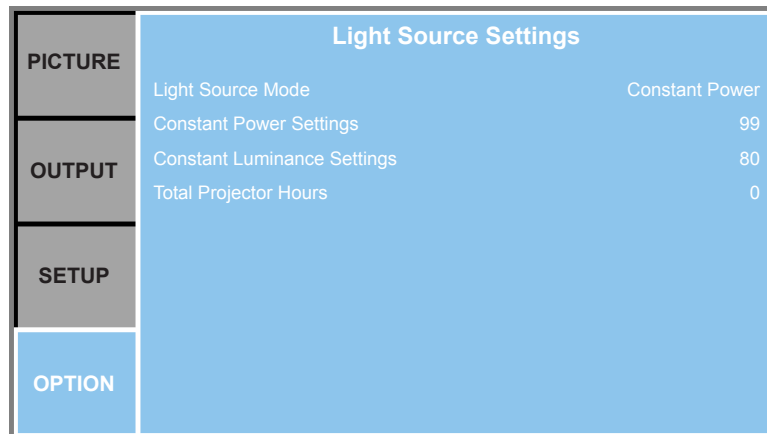

ITEM	DESCRIPTION
Light Source Mode	Select Constant Power , Constant Luminance , or Eco Mode . When in Eco Mode , the projector will adjust to the lowest fan speed and switch the light source power to the minimum setting.
Constant Power Settings	Set the value of the light source power (in Watts).
Constant Luminance Settings	Set the value for the Constant Luminance to maintain constant brightness. The light sensor will monitor the light level and will apply more power as the light source brightness decays naturally over time. When the light source setting reaches maximum power, it will remain at this setting. Note that the light sensor needs to be calibrated for Constant Luminance mode to work properly.
Total Projector Hours	Display the projection time.

Control Your Projector Using Web Browser

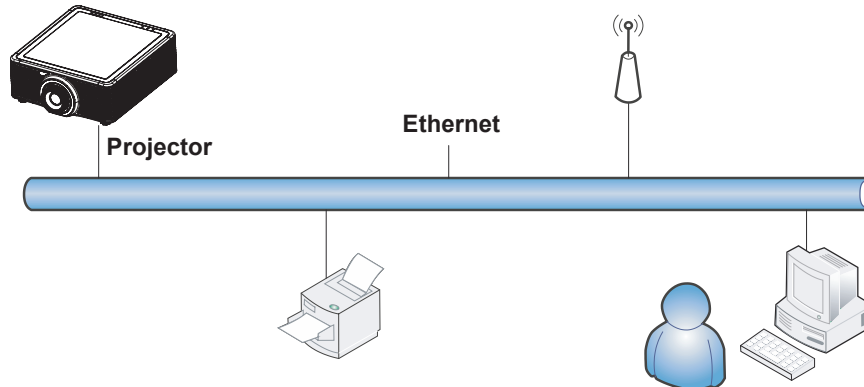

Wired LAN Terminal functionalities

Remote control and monitoring of a projector from a PC (or Laptop) via wired LAN is also possible. Compatibility with Crestron control boxes enables not only collective projector management on a network but also management from a control panel on a PC (or Laptop) browser screen.

- Crestron is a registered trademark of Crestron Electronics, Inc. of the United States.

Supported External Devices

This projector is supported by the specified commands of the Crestron Electronics controller and related software (ex, RoomView®).

<http://www.crestron.com/>

The projector supports AMX and PJ-Link as well.

<http://www.amx.com/>

<http://pjlink.jbmia.or.jp/>

For more detail of information about the diverse types of external devices which can be connected to the Ethernet port and remote/control the projector, as well as the related control commands supporting for each external device, kindly please get contact with the Support-Service team directly.

LAN_RJ45

1. Connect an RJ45 cable to Ethernet port on the projector and the PC (Laptop).

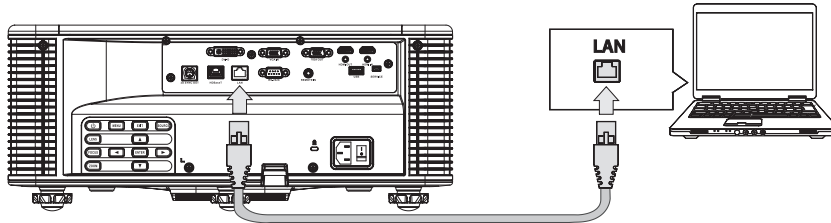

2. On the PC (Laptop), select **Start** → **Control Panel** → **Network and Internet**.

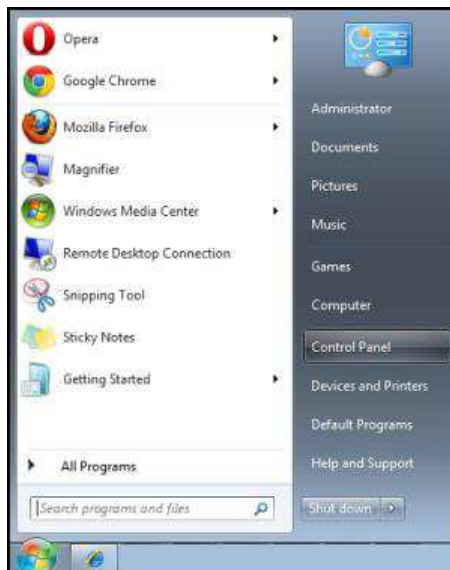

3. Right-click on **Local Area Connection**, and select **Properties**.

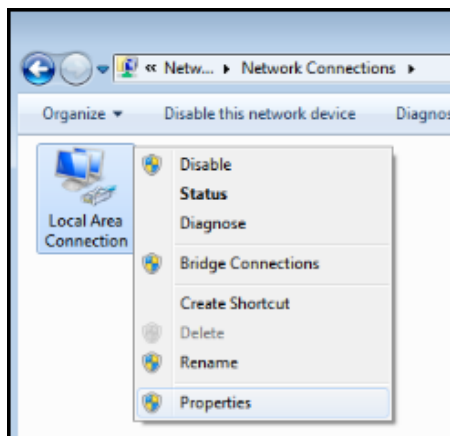

4. In the **Properties** window, select the **Networking** tab, and select **Internet Protocol Version 4 (TCP/IPv4)**.

5. Click **Properties**.

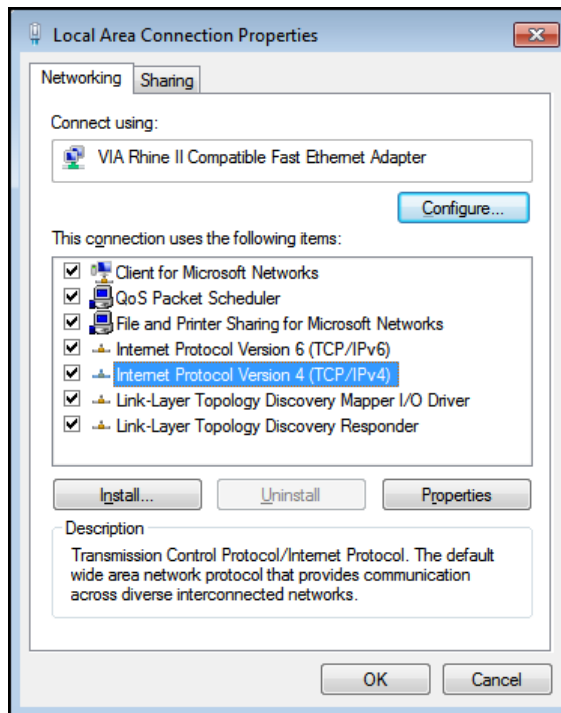

6. Click **Use the following IP address** and fill in the IP address and Subnet mask, then click **OK**.

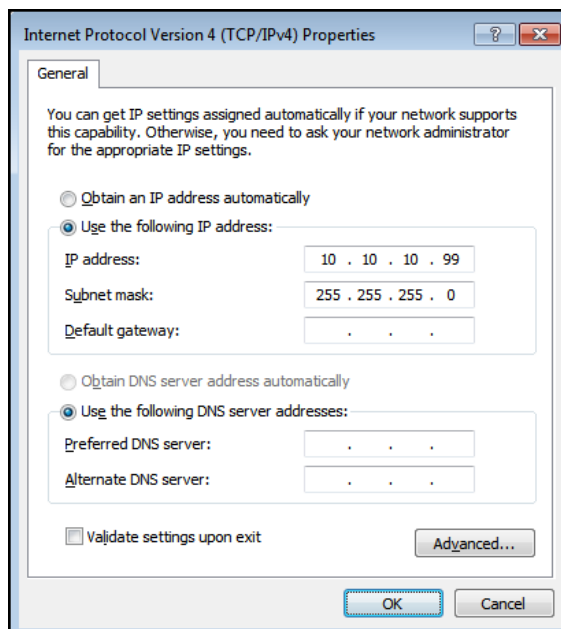

7. Press the **Menu** button on the projector.

8. Select **SETUP** → **Communications** → **LAN**.

9. After getting into **LAN**, input the following:

- DHCP: Off
- IP Address: 10.10.10.10
- Subnet Mask: 255.255.255.0
- Default Gateway: 0.0.0.0

10. Select the **Apply** → **Yes** to confirm the settings, and then wait until finished.

11. Open a web browser (for example, Microsoft Internet Explorer with Adobe Flash Player 9.0 or higher). In the Address bar, input the IP address: 10.10.10.10.

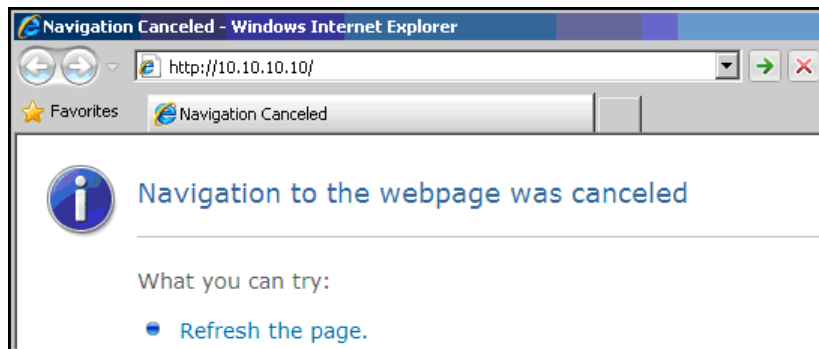

12. Press the **Enter** / ► button.

The projector is setup for remote management. The LAN/RJ45 function displays as follows.

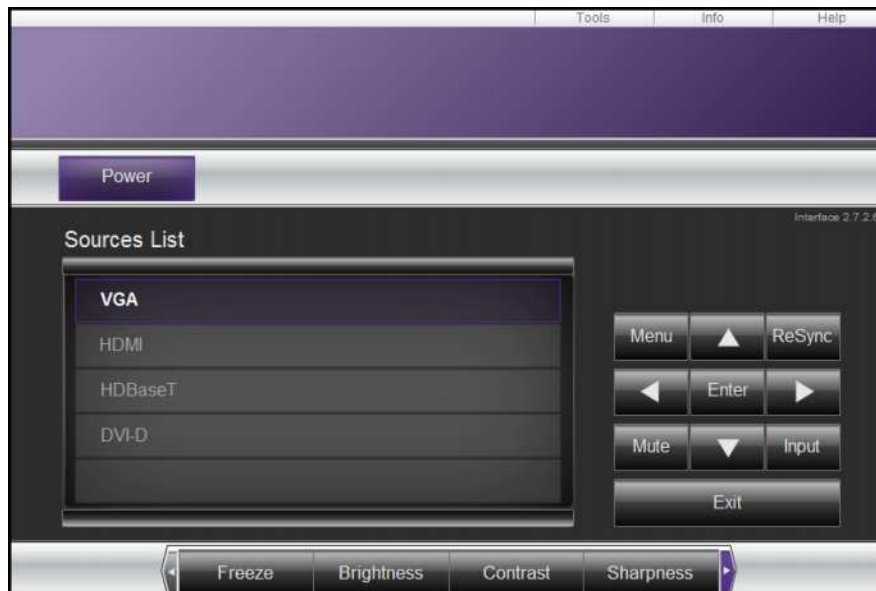

The screenshot shows a web-based configuration interface for a projector. It features a navigation bar at the top with 'Tools', 'Info', and 'Help' links. The main content area is divided into several sections:

- Crestron Control:** Includes input fields for IP Address (192.168.0.2), IP ID (5), and Port (41794), with a 'Send' button.
- Projector:** Includes input fields for Projector Name (SSID@800100574), Location (Room), and Assigned To (EK-620U), with a 'Send' button.
- Network Configuration:** Includes a 'DHCP' checkbox (unchecked), and input fields for IP Address (192.168.0.100), Subnet Mask (255.255.255.0), and Default Gateway (192.168.0.100), with a 'Send' button.
- User Password:** Includes an 'Enabled' checkbox (unchecked), and input fields for New Password and Confirm, with a 'Send' button.
- Admin Password:** Includes an 'Enabled' checkbox (unchecked), and input fields for New Password and Confirm, with a 'Send' button.

At the bottom center, there is a large 'Exit' button. The Crestron logo is visible in the bottom left corner, and 'Expansion Options' is in the bottom right corner.

CATEGORY	ITEM	INPUT-LENGTH
Crestron Control	IP Address	15
	IP ID	3
	Port	5
Projector	Projector Name	10
	Location	10
	Assigned To	10
Network Configuration	DHCP (Enabled)	(N/A)
	IP Address	15
	Subnet Mask	15
	Default Gateway	15
User Password	Enabled	(N/A)
	New Password	10
	Confirm	10
Admin Password	Enabled	(N/A)
	New Password	10
	Confirm	10

For more information, please visit <http://www.crestron.com>.

Warping & Blending function

The Warping & Blending application software and its manual can be downloaded from EIKI website.

Presentation function

The presenter application software and its manual can be downloaded from EIKI website.

URL: <http://www.eiki.com>

RS232 by Telnet Function

Besides projector connected to RS232 interface with “Hyper-Terminal” communication by dedicated RS232 command control, there is alternative RS232 command control way, so called “RS232 by TELNET” for LAN/RJ45 interface.

Quick Start-Guide for “RS232 by TELNET”

Check and get the IP-Address on OSD of the projector.

Make sure that laptop/PC can access the web-page of the projector.

Make sure that “Windows Firewall” setting to be disabled in case of “TELNET” function filtering out by laptop/PC.

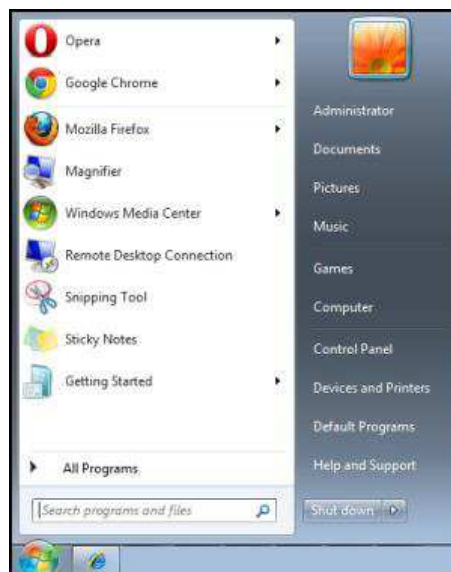

Start → All Programs → Accessories → Command Prompt

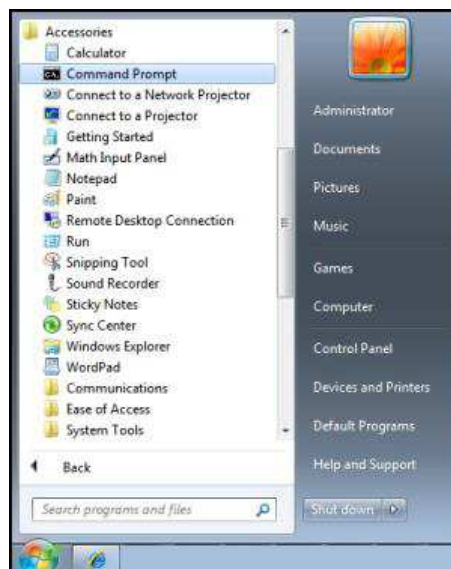

Input the command format like the below:

telnet ttt.xxx.yyy.zzz 3023 (the **Enter** button is pressed)

(**ttt.xxx.yyy.zzz**: IP-Address of the projector)

If Telnet-Connection ready, and user can have RS232 command input, then press the **Enter** button, the RS232 command will be workable.

How to have TELNET enabled in Windows VISTA / 7

By default installation for Windows VISTA, “TELNET” function is not included. But end-user can have it by way of “Turn Windows features On or Off” to be enabled.

1. Open “Control Panel” in Windows VISTA.



2. Open “Programs”.

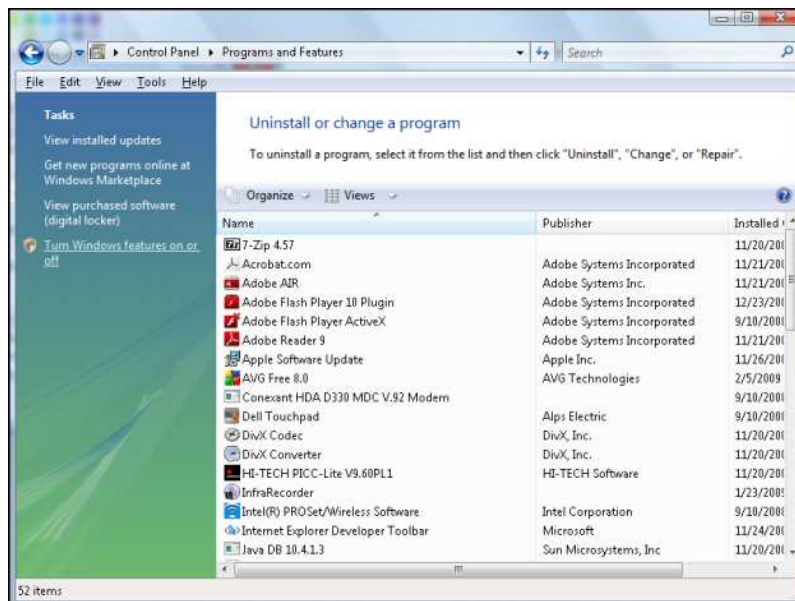

3. Select “Turn Windows features on or off” to open.

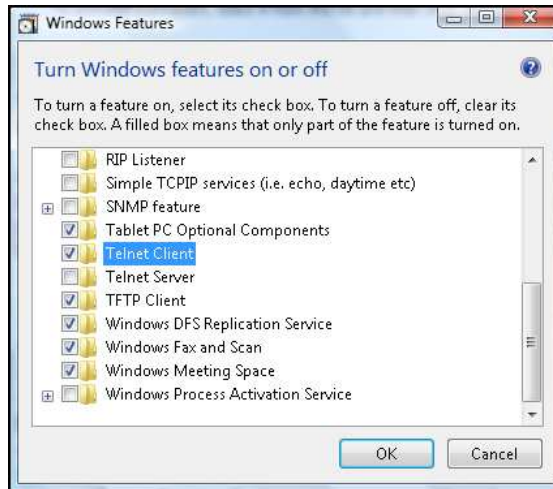

4. Have “Telnet Client” option checked, then click **OK**.

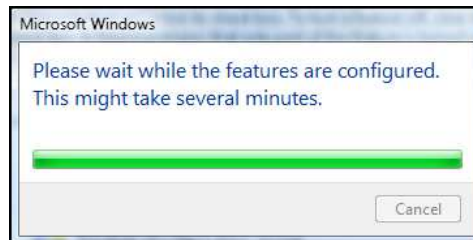

Specsheet for “RS232 by TELNET”:

1. Telnet: TCP
2. Telnet port: 3023
(for more detail, kindly please get contact with the service agent or team)
3. Telnet utility: Windows “TELNET.exe” (console mode)
4. Disconnection for RS232-by-Telnet control normally: Close Windows Telnet utility directly after TELNET connection ready.
5. Limitation 1 for Telnet-Control: there is less than 50 bytes for successive network payload for Telnet-Control application.
Limitation 2 for Telnet-Control: there is less than 31 bytes for one complete RS232 command for Telnet-Control.
Limitation 3 for Telnet-Control: Minimum delay for next RS232 command must be more than 200 (ms).
(* , In Windows built-in “TELNET.exe” utility, pressing the **Enter** button will create a “Carriage-Return” and “New-Line” code.)

MAINTENANCE AND SECURITY



Replacing the Projection Lens

Perform the following to replace the projection lens:

1. Center the lens. Use the **Lens H** or **Lens V** button (on the remote control) to adjust the lens at its center position.

Important:

- Ensure that the lens is at or near its center position.
- Attempting to remove the lens when at a large offset may cause damage to the lens assembly.

2. Press “” on the built-in keypad or press “” on the remote control twice to turn off the projector after cooling down.

3. Remove the lens cover from the lens.

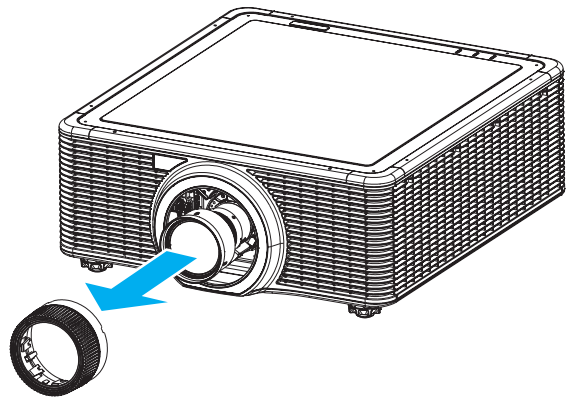

4. Rotate the lens counter-clockwise to disengage it from the lens mount.

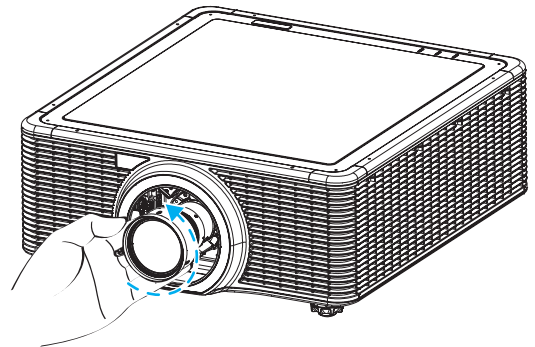

5. Remove the lens out of the lens mount.

6. With the label “TOP” on the lens assembly facing up, install the new lens. See “Installing the Projection Lens” on page 10.

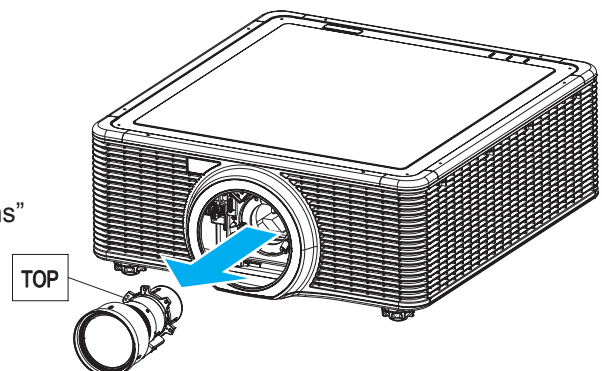

Cleaning the Projector

Cleaning the projector to remove dust and grime will help ensure trouble-free operation.

Warning:

- *Be sure to turn off and unplug the projector at least 30 minutes before cleaning. Failure to do so could result in a severe burn.*
- *Use only a dampened cloth when cleaning. Do not allow water to enter the ventilation openings on the projector.*
- *If a little water gets into the projector interior while cleaning, leave unplugged in a well-ventilated room for several hours before using.*
- *If a lot of water gets into the projector interior when cleaning, have the projector serviced.*

Cleaning the Lens

You can purchase Optical lens cleaner from most camera stores. Refer to the following to clean the projector lens.

- 1.** Apply a little Optical lens cleaner to a clean soft cloth. (Do not apply the cleaner directly to the lens.)
- 2.** Lightly wipe the lens in a circular motion.

Caution:

- *Do not use abrasive cleaners or solvents.*
- *To prevent discoloration or fading, avoid getting cleaner on the projector case.*

Cleaning the Case

Refer to the following to clean the projector case.

- 1.** Wipe off dust with a clean dampened cloth.
- 2.** Moisten the cloth with warm water and mild detergent (such as used to wash dishes), and then wipe the case.
- 3.** Rinse all detergent from the cloth and wipe the projector again.

Caution:

To prevent discoloration or fading of the case, do not use abrasive alcohol-based cleaners.

Using the Kensington® Lock

If you are concerned about security, attach the projector to a permanent object with the Kensington slot and a security cable.

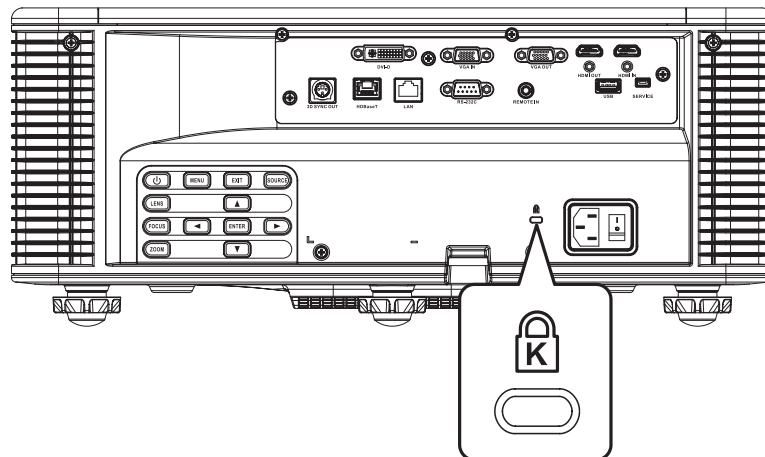

Note:

Contact your vendor for details on purchasing a suitable Kensington security cable.

The security lock corresponds to Kensington's MicroSaver Security System. If you have any comment, contact: Kensington, 2853 Campus Drive, San Mateo, CA 94403, U.S.A. Tel: 800-535-4242, <http://www.Kensington.com>.

Common Problems and Solutions

These guidelines provide tips to deal with problems you may encounter while using the projector. If the problem remains unsolved, contact your dealer for assistance.

Often after time spent troubleshooting, the problem is traced to something as simple as a loose connection. Check the following before proceeding to the problem-specific solutions.

- Use some other electrical device to confirm that the electrical outlet is working.
- Ensure the projector is turned on.
- Ensure all connections are securely attached.
- Ensure the attached device is turned on.
- Ensure a connected PC is not in suspending mode.
- Ensure a connected notebook computer is configured for an external display. (This is usually done by pressing an Fn-key combination on the notebook.)

Tips for Troubleshooting

- In each problem-specific section, try the steps in the order suggested. This may help you to solve the problem more quickly.
- Try to pin point the problem and thus avoid replacing non-defective parts. For example, if you replace batteries and the problem remains, put the original batteries back and go to the next step.
- Keep a record of the steps you take when troubleshooting: The information may be useful when calling for technical support or for passing on to service personnel.

LED Error Messages

The LED status indicators are located on the top of the projector. Each LED is defined below.

MESSAGE	LIGHT LED			STATUS LED			AV MUTE LED	
	GREEN	ORANGE	RED	GREEN	ORANGE	RED	GREEN	ORANGE
Standby State	-	-	-	Flashing	-	-	-	-
Power on (Warm up)	-	-	-	-	Flashing	-	-	-
Power on & Laser diode on	Steady	-	-	Steady	-	-	Steady	-
Power off (Cooling down)	-	-	-	-	Flashing	-	-	-
AV mute is off (Image is displayed)	Steady	-	-	Steady	-	-	Steady	-
AV mute is on (Image is black)	Steady	-	-	Steady	-	-	-	Steady
Projector communication	Steady	-	-	Flashing	-	-	Steady	-
Firmware upgrade	-	-	-	Flashing	Flashing	-	-	-
Error (Over temperature)	-	-	-	-	-	Steady	-	-
Error (Fan failure)	-	-	-	-	-	Flashing	-	-

Image Problems

Problem: No image appears on the screen

1. Verify the settings on your notebook or desktop PC.
2. Turn off all equipment and power on again in the correct order.

Problem: The image is blurred

1. Press the **Focus** button to adjust the focus on the projector.
2. Press the **Auto** button on the remote control to automatically optimize image.
3. Ensure the projector-to-screen distance is within the specified range.
4. Check that the projector lens is clean.

Problem: The image is wider at the top or bottom (trapezoid effect)

1. Position the projector so it is as perpendicular to the screen as possible.
2. Press the **Keystone H** or **Keystone V** button on the remote control to correct the problem.

Problem: The image is reversed

Check the **Rear Projection** on the **Setup** menu of the OSD.

Problem: The image is streaked

1. Set the **Phase** and **Frequency** settings on the **Picture** menu of the OSD to the default settings.
2. Ensure the problem is not caused by a connected PC's video card, connect to another computer.

Problem: The image is flat with no contrast

Adjust the **Contrast** setting on the **Picture** menu of the OSD.

Problem: The color of the projected image does not match the source image

Adjust the **Color Temperature** and **Gamma** settings on the **Picture > Advanced** menu of the OSD.

Laser Diode Problems

Problem: There is no light from the projector

1. Check that the power cable is securely connected.
2. Ensure the power source is good by testing with another electrical device.
3. Restart the projector in the correct order and check that the Light LED is in green.

Problem: The laser diode goes off

1. Power surges can cause the laser diode to turn off. Re-plug power cord. If the Light LED is in orange, this indicates that the laser diode time has expired. Then press “

Remote Control Problems

Problem: The projector does not respond to the remote control

1. Direct the remote control towards remote sensor on the projector.
2. Ensure the path between remote and sensor is not obstructed.
3. Turn off any fluorescent lights in the room.
4. Make sure that the batteries are installed with the correct polarity.
5. Replace the batteries.
6. Turn off other Infrared-enabled devices in the vicinity.
7. Have the remote control serviced.

Having the Projector Serviced

If you are unable to solve the problem, you should have the projector serviced. Pack the projector in the original carton. Include a description of the problem and a checklist of the steps you took when trying to fix the problem. The information may be useful to service personnel. For servicing, return the projector to the place you purchased it.

HDMI Q & A

Q. What is the difference between a “Standard” HDMI cable and a “High-Speed” HDMI cable?

Recently, HDMI Licensing, LLC announced that cables would be tested as Standard or High-Speed cables.

- Standard (or “category 1”) HDMI cables have been tested to perform at speeds of 75Mhz or up to 2.25Gbps, which is the equivalent of a 720p/1080i signal.
- High Speed (or “category 2”) HDMI cables have been tested to perform at speeds of 340Mhz or up to 10.2Gbps, which is the highest bandwidth currently available over an HDMI cable and can successfully handle 1080p signals including those at increased color depths and/or increased refresh rates from the Source. High-Speed cables are also able to accommodate higher resolution displays, such as WQXGA cinema monitors (resolution of 2560 x 1600).

Q. How do I run HDMI cables longer than 10 meters?

There are many HDMI Adapters working on HDMI solutions that extend a cable's effective distance from the typical 10 meter range to much longer lengths. These companies manufacture a variety of solutions that include active cables (active electronics built into cables that boost and extend the cable's signal), repeaters, amplifiers as well as CAT5/6 and fiber solutions.

Q. How can I tell if a cable is an HDMI certified cable?

All HDMI products are required to be certified by the manufacturer as part of the HDMI Compliance Test Specification. However, there may be instances where cables bearing the HDMI logo are available but have not been properly tested. HDMI Licensing, LLC actively investigates these instances to ensure that the HDMI trademark is properly used in the market. We recommend that consumers buy their cables from a reputable source and a company that is trusted.

For more detail information check <http://www.hdmi.org/learningcenter/faq.aspx#49>.

SPECIFICATIONS

Specifications

ITEM	DESCRIPTION
Display type	"TI" 0.67" WUXGA DMD, Type A, DC3
Resolution	WUXGA (1920 x 1200)
Zoom/focus	Motorized
Zoom ratio	Depend on Lens
Keystone correction	Vertical: +/- 20 degrees, Horizontal: +/- 20 degrees
Projection methods	Front, Rear, Desktop/Ceiling (Rear, Front)
Data compatibility	VGA, SVGA, XGA, WXGA, SXGA, SXGA+, UXGA, WUXGA, Mac
Video compatibility	1080 i/p, 720p, 576 i/p, 480 i/p
H-Sync	15, 31~91.4KHz
V-Sync	24~30Hz, 47~120Hz
Safety Certification	UL/cUL, FCC, CE, CB, CCC, KC/KCC
Operation temperature	5° ~ 40°C
Dimensions (W x H x D)	484 x 181 x 509 mm (without lens and elevators)
AC Input	AC 100 – 240 V @ 50/60 Hz
Power Consumption	370W (ECO brightness mode); 765W (Normal brightness mode)
Laser Diode Power	35W@3A (Normal Mode)
Laser Diode Life	20,000 Hours Standard @ 35W (Normal Mode)
Input Terminals	1 x HDMI (version1.4) (with locking screw) 1 x DVI-D (only support digital signal) 1 x VGA IN (D-Sub 15pin) (Computer In) 1 x HDBaseT
Output Terminals	1 x HDMI (version1.4) (with locking screw) 1 x VGA Out (Support VGA loops through to monitor) (Monitor Out) 1 x 3D SYNC Out
Control Terminals	1 x RS232 (D-sub 9 pin) (PC Control) 1 x Wired in (3.5mm phone jack) (Remote In) 1 x USB type A (for WiFi dongle purpose) 1 x Mini USB (for LAN FW upgrade only) (Service) 1 x RJ45 (LAN) 1 x IR Receiver (On the Front side and Top side)
Security	Kensington lock Security bar

Note:

For questions regarding product specifications, please contact your local distributor.

Projection Distance vs. Projection Size

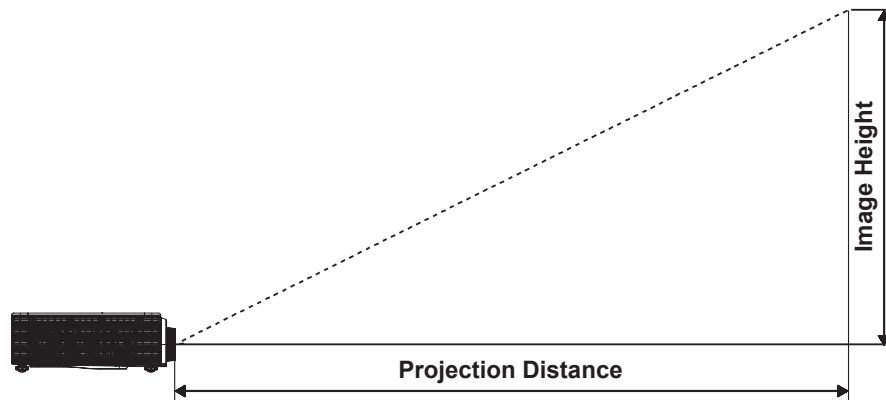

Projection Distance and Size Table

PLATFORM			EK-625U WUXGA (16:10)														
DMD			0.67"														
PROJECTION LENS			A16	A15		A01		A02		A05		A06		A03		A13	
THROW RATIO			0.361 (120")	0.75-0.95		0.95-1.22		1.22-1.53		1.22-1.53		1.22-1.52		1.53-2.92		2.90-5.50	
ZOOM RATIO			NA	1.26X		1.28X		1.25X		1.25X		1.25X		1.9X		1.9X	
THROW DISTANCE			0.96- 2.28M	0.81-6.13M		1.02-7.88M		1.31-9.89M		1.31-9.89M		1.32-9.82M		1.64-18.87M		3.12-35.54M	
PROJECTION SCREEN SIZE			PROJECTION DISTANCE (M)														
THROW RATIO			0.361	0.75	0.95	0.95	1.22	1.22	1.53	1.22	1.53	1.22	1.52	1.53	2.92	2.9	5.5
DIAGONAL (INCH)	HEIGHT (M)	WIDTH (M)		MIN (M)	MAX (M)	MIN (M)	MAX (M)	MIN (M)	MAX (M)	MIN (M)	MAX (M)	MIN (M)	MAX (M)	MIN (M)	MAX (M)	MIN (M)	MAX (M)
50	0.67	1.08	NA	0.81	1.03	1.02	1.32	1.31	1.65	1.31	1.65	1.32	1.64	1.65	3.14	3.13	5.94
60	0.81	1.29	NA	0.97	1.23	1.23	1.57	1.58	1.98	1.58	1.98	1.57	1.96	1.98	3.77	3.74	7.1
70	0.94	1.51	NA	1.13	1.43	1.43	1.84	1.84	2.31	1.84	2.31	1.84	2.30	2.31	4.4	4.38	8.31
80	1.08	1.72	NA	1.29	1.63	1.64	2.1	2.1	2.64	2.1	2.64	2.10	2.61	2.64	5.03	4.99	9.46
90	1.21	1.94	NA	1.46	1.84	1.84	2.36	2.36	2.97	2.36	2.97	2.37	2.95	2.97	5.66	5.63	10.67
100	1.35	2.15	NA	1.61	2.04	2.05	2.63	2.63	3.3	2.63	3.3	2.62	3.27	3.3	6.29	6.24	11.83
110	1.48	2.37	NA	1.78	2.25	2.25	2.89	2.89	3.62	2.89	3.62	2.89	3.60	3.62	6.92	6.87	13.04
120	1.62	2.58	0.96	1.94	2.45	2.46	3.15	3.15	3.95	3.15	3.95	3.15	3.92	3.95	7.55	7.48	14.19
130	1.75	2.8	1.04	2.1	2.66	2.66	3.42	3.42	4.28	3.42	4.28	3.42	4.26	4.28	8.18	8.12	15.4
140	1.88	3.02	1.11	2.27	2.87	2.86	3.68	3.68	4.61	3.68	4.61	3.68	4.59	4.61	8.8	8.76	16.61
150	2.02	3.23	1.18	2.42	3.07	3.07	3.94	3.94	4.94	3.94	4.94	3.94	4.91	4.94	9.43	9.37	17.77
160	2.15	3.45	1.26	2.59	3.28	3.27	4.2	4.2	5.27	4.2	5.27	4.21	5.24	5.27	10.06	10.01	18.98
170	2.29	3.66	1.33	2.75	3.48	3.48	4.47	4.47	5.6	4.47	5.6	4.47	5.56	5.6	10.69	10.61	20.13
180	2.42	3.88	1.40	2.91	3.69	3.68	4.73	4.73	5.93	4.73	5.93	4.73	5.90	5.93	11.32	11.25	21.34
190	2.56	4.09	1.47	3.07	3.89	3.89	4.99	4.99	6.26	4.99	6.26	4.99	6.22	6.26	11.95	11.86	22.5
200	2.69	4.31	1.55	3.23	4.09	4.09	5.25	5.25	6.59	5.25	6.59	5.26	6.55	6.59	12.58	12.5	23.71

250	3.37	5.38	1.91	4.04	5.11	5.11	6.57	6.57	8.24	6.57	8.24	6.56	8.18	8.24	15.72	15.6	29.59
300	4.04	6.46	2.28	4.85	6.13	6.14	7.88	7.88	9.89	7.88	9.89	7.88	9.82	9.89	18.87	18.73	35.53

Note:

- *The values in the tables are approximate and may be slightly different from the actual measurements.*
- *In case of ceiling mount, it is necessary to match at the spot.*

Timing Mode Table

SIGNAL TYPE	RESOLUTION	FRAME RATE (Hz)	QD881	VGA	HDMI	DVI	HDBASET
PC	640x480	60	DMT0660	V	V	V	V
	640x480	72	DMT0672	V	V	V	V
	640x480	75	DMT0675	V	V	V	V
	640x480	85	DMT0685	V	V	V	V
	640x480	66.6	APP0667	—	V	V	V
	720x400	70	IBM0770H	V	V	V	V
	800x600	60	DMT0860	V	V	V	V
	800x600	72	DMT0872	V	V	V	V
	800x600	75	DMT0875	V	V	V	V
	800x600	85	DMT0885	V	V	V	V
	800x600	120	CVR0812	V	V	V	V
	832x624	75	8362A75	V	V	V	V
	848x480	50	CVT0850H	—	V	V	V
	848x480	60	CVT0860H	—	V	V	V
	848x480	75	CVT0875H	—	V	V	V
	848x480	85	CVT0885H	—	V	V	V
	1024x768	60	DMT1060	V	V	V	V
	1024x768	75	DMT1075	V	V	V	V
	1024x768	85	DMT1085	V	V	V	V
	1024x768	120	CVR1012	V	V	V	V
	1152x720	50	CVT1150D	—	V	V	V
	1152x720	60	CVT1160D	—	V	V	V
	1152x720	75	CVT1175D	—	V	V	V
	1152x720	85	CVT1185D	—	V	V	V
	1152x864	60	CVT1160	V	V	V	V
	1152x864	70	DMT1170	V	V	V	V
	1152x864	75	DMT1175	V	V	V	V
	1152x864	85	DMT1185	V	V	V	V
	1152x870	75	APP1175	—	V	V	V
	1280x720	50	CVT1250H	—	V	V	V
	1280x720	60	CVT1260H	V	V	V	V
	1280x720	75	CVT1275H	V	V	V	V
	1280x720	85	CVT1285H	V	V	V	V
	1280x720	120		V	V	V	V
	1280x768	60	CVT1260E	V	V	V	V
	1280x768	75	CVT1275E	V	V	V	V
	1280x768	85	CVT1285E	V	V	V	V
	1280x800	50	CVT1250_	V	V	V	V
	1280x800	60	DMT1260D	V	V	V	V
	1280x800	75	CVT1275_	V	V	V	V
1280x800	85	CVT1285_	V	V	V	V	

SIGNAL TYPE	RESOLUTION	FRAME RATE (Hz)	QD881	VGA	HDMI	DVI	HDBASET
PC	1280x960	50	CVT1250	—	V	V	V
	1280x960	60	CVT1260	V	V	V	V
	1280x960	75	CVT1275	V	V	V	V
	1280x960	85	CVT1285	V	V	V	V
	1280x1024	50	CVT1250G	—	V	V	V
	1280x1024	60	DMT1260G	V	V	V	V
	1280x1024	75	DMT1275G	V	V	V	V
	1280x1024	85	DMT1285G	V	V	V	V
	1360x768	50	CVT1350H	—	V	V	V
	1360x768	60	DMT1360H	—	V	V	V
	1360x768	75	CVT1375H	—	V	V	V
	1360x768	85	CVT1385H	—	V	V	V
	1366x768	60	DMR1360H	V	V	V	V
	1400x1050	50	CVT1450	—	V	V	V
	1400x1050	60	CVT1460	—	V	V	V
	1400x1050	75	CVT1475	V	V	V	V
	1440x900	60	CVT1460D	V	V	V	V
	1440x900	75	CVT1475D	—	V	V	V
	1600x900	60	DMR1660H	—	V	V	V
	1600x1200	60	DMT1660	V	V	V	V
	1680x1050	60	CVT1660D	V	V	V	V
	1920X1080	50	CVT1950H	—	V	V	V
	1920X1080	60	CVR1960H	V	V	V	V
	1920X1200RB	60	CVR1960D	V	V	V	V
1920X1200RB	50	CVT1950D	V	V	V	V	
NTSC	NTSC (M, 4.43)	60		—	—	—	—
PAL	PAL (B,G,H,I)	50		—	—	—	—
	PAL (N)	50		—	—	—	—
	PAL (M)	60		—	—	—	—
SECAM	SECAM (M)	50		—	—	—	—
SDTV	480i	60		V	V	V	V
	576i	50		V	V	V	V
EDTV	480p	60		V	V	V	V
	576p	50		V	V	V	V
HDTV	1080i	25		V	V	V	V
	1080i	29		V	V	V	V
	1080i	30		V	V	V	V
	720p	50		V	V	V	V
	720p	59		V	V	V	V
	720p	60		V	V	V	V
	1080p	23		V	V	V	V
	1080p	24		V	V	V	V
	1080p	25		V	V	V	V
1080p	29		V	V	V	V	

SIGNAL TYPE	RESOLUTION	FRAME RATE (Hz)	QD881	VGA	HDMI	DVI	HDBaseT
HDTV	1080p	30		V	V	V	V
	1080p	50		V	V	V	V
	1080p	59		V	V	V	V
	1080p	60		V	V	V	V
Mandatory 3D	Frame Packing 1080p	24		—	V	—	V
	Frame Packing 720p	50		—	V	—	V
	Frame Packing 720p	60		—	V	—	V
	Side by Side 1080i	50		—	V	—	V
	Side by Side 1080i	60		—	V	—	V
	Top and Bottom 720p	50		—	V	—	V
	Top and Bottom 720p	60		—	V	—	V
	Top and Bottom 1080p	24		—	V	—	V
Frame sequential 3D	800x600	120		—	V	—	V
	1024x768	120		—	V	—	V
	1280x720	120		—	V	—	V

V : Frequency supported

— : Frequency not supported

Projector Dimensions

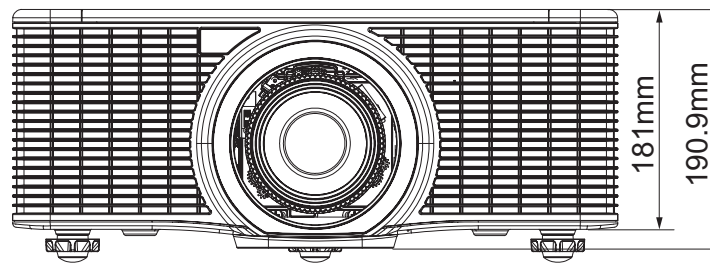
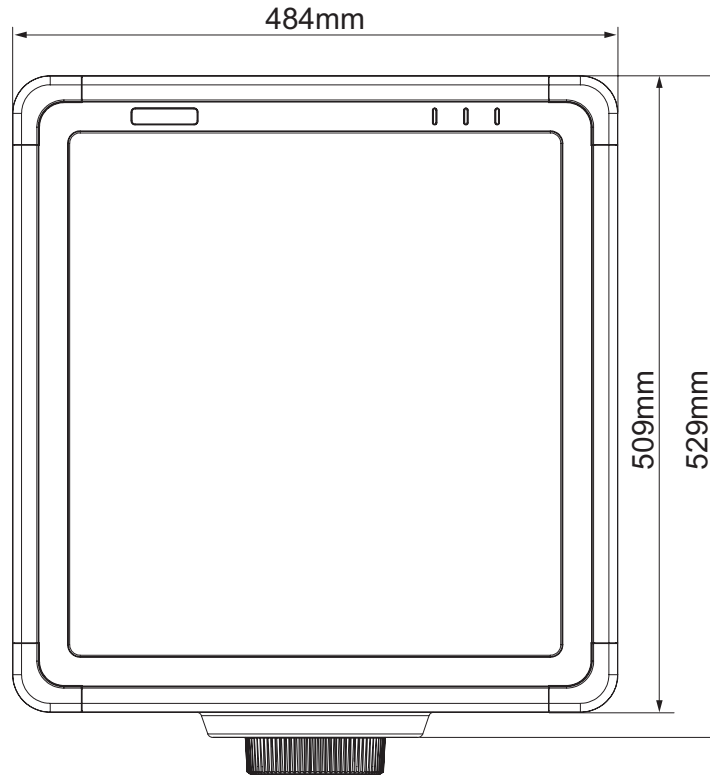

FCC Warning

This equipment has been tested and found to comply with the limits for a Class A digital device pursuant to Part 15 of the FCC Rules. These limits are designed to provide reasonable protection against harmful interference when the equipment is operated in a commercial environment.

This equipment generates, uses, and can radiate radio frequency energy and, if not installed and used in accordance with the instruction manual, may cause harmful interference to radio communications. Operation of this equipment in a residential area is likely to cause harmful interference in which case the user will be required to correct the interference at his/her own expense.

Changes or modifications not expressly approved by the parties responsible for compliance could void the user's authority to operate the equipment.

Canada

This class A digital apparatus complies with Canadian ICES-003.

Safety Certifications

UL/cUL, FCC, CE, CB, CCC, KC/KCC

EIKI

U.S.A.

EIKI International, Inc.
30251 Esperanza
Rancho Santa Margarita
CA 92688-2132
U.S.A.
Tel: +1 800-242-3454 +1 949-457-0200
Fax: +1 800-457-3454 +1 949-457-7878
E-Mail: usa@eiki.com

Deutschland & Österreich

EIKI Deutschland GmbH
Am Frauwald 12
65510 Idstein
Deutschland
Tel: +49 6126-9371-0
Fax: +49 6126-9371-11
E-Mail: info@eiki.de

South East Asia

EIKI Industrial (M) Sdn Bhd
No. 11, Nouvelle Industrial Park,
Lorong Teknologi B, Taman Sains
Selangor 1, Kota Damansara PJU5,
47810 Petaling Jaya, Selangor Darul Ehsan,
Malaysia
Tel: +60 3-6157-9330
Fax: +60 3-6157-1320
E-Mail: sales@eiki.my

China

EIKI (Shanghai) Co., Ltd.
LAKESIDE OASIS MIDDLE RING
BUSINESS CENTRE
Block 1, Room 606,
1628, Jin Sha Jiang Road
Shanghai, 200333
CHINA
Tel: +86 21-3251-3993
Service Hot line: +86 21-3251-3995
Fax: +86 21-3251-3997
E-mail: info@eiki-china.com

Canada

EIKI CANADA - Eiki International, Inc.
9170 County Road 93, Suite 304,
Midland, ON, L4R 4K4, Canada
Tel: +1 800-563-3454
+1 705-527-4084
E-Mail: canada@eiki.com

Eastern Europe

EIKI CZECH SPOL. s.r.o.
Nad Cementárnou 1163/4a
Praha 4, Podolí
147 00
Czech Republic
Tel: +420 241-410-928
+420 241-403-095
Fax: +420 241-409-435
E-Mail: info@eiki.cz

Oceania

EIKI AUSTRALIA PTY LTD
Level 5, 11 Queens Road,
Melbourne, Victoria 3004
Tel: +61 03-8530-7048
Fax: +61 03-9820-5834
E-Mail: sales@eiki.net.au

Japan & Worldwide

EIKI Industrial Company Limited.
6-23 Teramoto, Itami-shi, Hyogo,
664-0026 JAPAN
Tel: +81 72-782-7492
Fax: +81 72-781-5435

WorldWide Website <http://www.eiki.com>