

# Video Projector

## Operating Instructions

Before operating the unit, please read this manual and supplied Quick Reference Manual thoroughly and retain them for future reference.

VPL-HW45 **ES**

**SXRD** **HDMI**  
Silicon X-tal Reflective Display

---

# Table of Contents

---

## **Location of Controls**

Front/Right Side .....	3
Rear/Bottom .....	4
Remote Control .....	5

---

## **Connections and Preparations**

Installing the Unit .....	6
Adjusting the Picture Position .....	7
Connecting to Video Equipment or a Computer .....	11

---

## **Projecting**

Projecting the Picture .....	13
Turning Off the Power .....	13
Watching 3D Video Images .....	14
Using the 3D Glasses .....	14
Selecting the Aspect Ratio According to the Video Signal .....	16
Selecting the Picture Viewing Mode .....	18

---

## **Using the Menus**

Operation through the Menus .....	19
Picture Menu .....	21
Screen Menu .....	26
Setup Menu .....	28
Function Menu .....	29
Items Locked by Settings	
Lock .....	31
Installation Menu .....	32
Information Menu .....	34
About the Preset Memory .....	34

---

## **Error Handling**

Troubleshooting .....	35
Warning Indicators .....	38
Message Lists .....	39

---

## **Others**

Updating the Software .....	40
About the x.v.Color .....	40
About the simulated 3D feature .....	40
Replacing the Lamp and the Air Filter and Cleaning the Ventilation Holes (intake) .....	41
Cleaning the Air Filter .....	44
Fitting the Lens Cap .....	45
Cleaning .....	45
Specifications .....	46
Preset Signals .....	47
Input Signals and Adjustable/Setting Items .....	49
Compatible 3D Signals .....	50
3D Signals and Adjustable/Setting Items .....	50
Aspect Mode .....	51
Motionflow .....	52
Storage Conditions of Adjustable/Setting Items .....	53
Projection Distance and Lens Shift Range .....	55
Dimensions .....	57
NOTICES AND LICENCES FOR SOFTWARE USED IN THIS PRODUCT .....	60
Index .....	76

# Location of Controls

## Front/Right Side

The buttons on the control panel have the same names as those on the remote control.

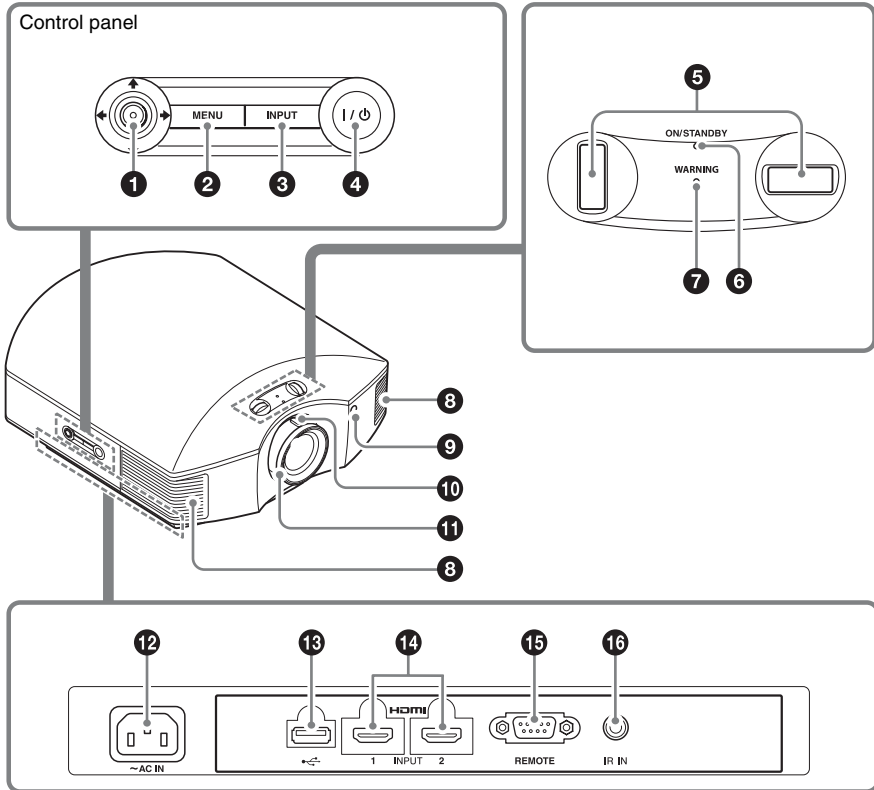

- ① ↑/↓/←/→ (arrow)/⊙ (enter) button (page 19)
- ② MENU button (page 19)
- ③ INPUT button (page 13)
- ④ I/⏻ (ON/STANDBY) button (page 7)
- ⑤ Lens shift dials (page 8)
- ⑥ ON/STANDBY indicator (page 38)
- ⑦ WARNING indicator (page 38)
- ⑧ Ventilation holes (exhaust)
- ⑨ Remote control detector (page 7)
- ⑩ Zoom lever (page 9)
- ⑪ Focus ring (page 10)
- ⑫ AC IN socket (page 7)
- ⑬ USB connector (page 40)
- ⑭ HDMI 1/HDMI 2 connector (page 11)

**15 REMOTE connector**

Connects to a computer, etc. for remote control.

**16 IR IN connector**

Inputs signals to control the unit.

---

## Rear/Bottom

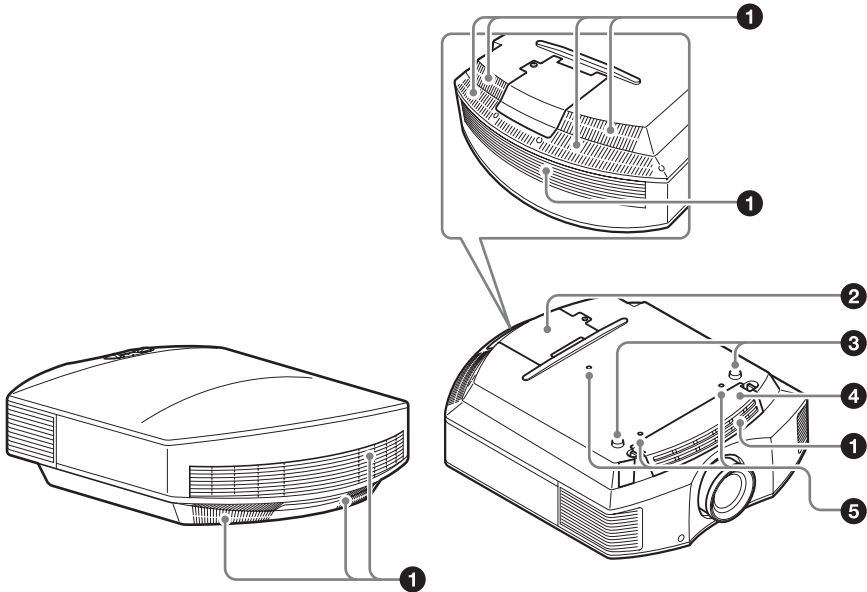

- 1 Ventilation holes (intake) (page 43)**
- 2 Lamp cover (page 42)**
- 3 Front feet (adjustable) (page 10)**
- 4 Filter holder (page 43)**
- 5 Projector suspension support attaching hole (page 58)**

# Remote Control

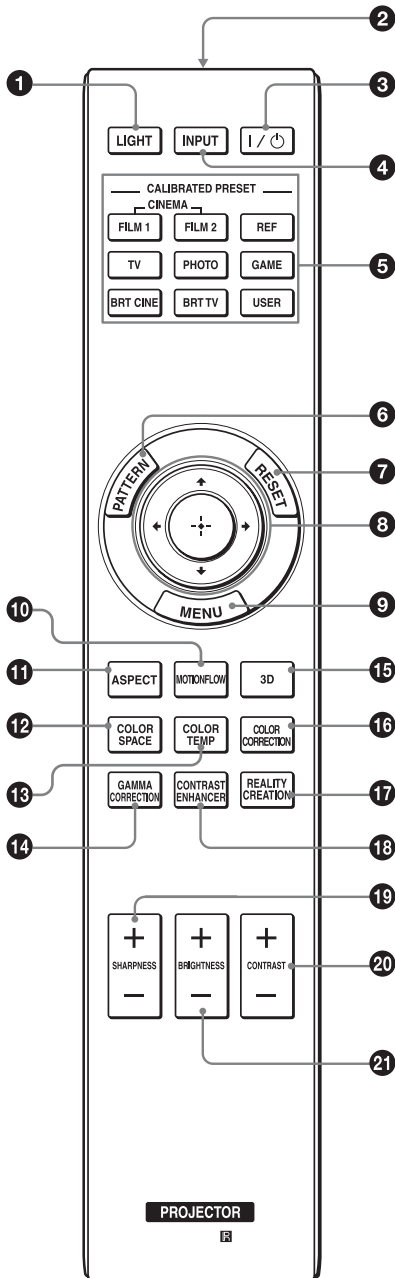

- 1 LIGHT button**  
Illuminates the buttons on the remote control.
- 2 Infrared transmitter**
- 3 I/⏻ (ON/STANDBY) button**  
(page 7)
- 4 INPUT button** (page 13)
- 5 CALIBRATED PRESET buttons**  
(page 18)
- 6 PATTERN button** (page 7)
- 7 RESET button** (page 20)
- 8 ↑/↓/←/→ (arrow)/ ⊕ (enter) buttons** (page 19)
- 9 MENU button** (page 19)
- 10 MOTIONFLOW button** (page 22)
- 11 ASPECT button** (page 16)
- 12 COLOR SPACE button** (page 25)
- 13 COLOR TEMP button** (page 23)
- 14 GAMMA CORRECTION button**  
(page 24)
- 15 3D button** (page 14)
- 16 COLOR CORRECTION button**  
(page 24)
- 17 REALITY CREATION button**  
(page 22)
- 18 CONTRAST ENHANCER button**  
(page 22)
- 19 SHARPNESS +/- button**  
(page 23)
- 20 CONTRAST +/- button** (page 22)
- 21 BRIGHTNESS +/- button**  
(page 22)

# Connections and Preparations

This section describes how to install the unit and screen, how to connect the equipment from which you want to project the picture, etc.

## Installing the Unit

The lens shift allows you to have broader options for placing the unit and viewing pictures easily.

The installation distance between the unit and a screen varies depending on the size of the screen or whether or not you use the lens shift features. Install this unit so that it fits the size of your screen. For details on the distance between the unit and the screen (the projection distance) and the size of projected video, see “Projection Distance and Lens Shift Range” (page 55).

- 1 Position the unit so that the lens is parallel to the screen.

### Top view

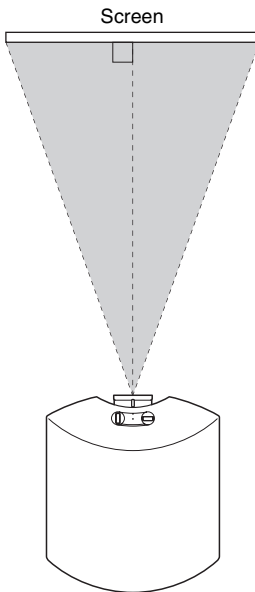

- 2 Project an image on the screen and adjust the picture so that it fits the screen (page 7).

### Note

When using a screen with an uneven surface, stripes pattern may rarely appear on the screen depending on the distance between the screen and the unit or the zooming magnifications. This is not a malfunction of the unit.

# Adjusting the Picture Position

Project an image on the screen and then adjust the picture position.

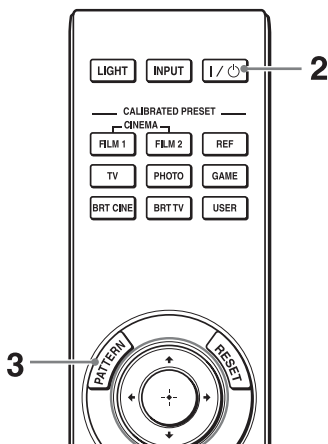
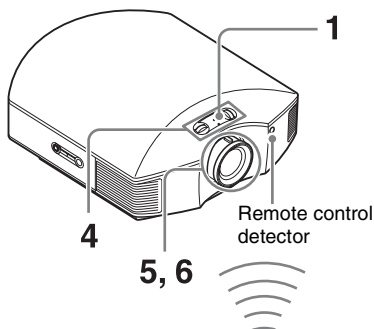

## Tip

The I/ON (ON/STANDBY), INPUT, MENU, and  $\uparrow/\downarrow/\leftarrow/\rightarrow/\odot$  (joystick) buttons on the side panel of the unit function the same as those on the remote control.

## Note

Depending on the installation location of the unit, you may not be able to control it with the remote control. In this case, point the remote control to the screen instead of the projector.

- 1 After connecting the AC power cord to the unit, plug the AC power cord into a wall outlet.

The ON/STANDBY indicator lights in red and the unit goes into standby mode.

## ON/STANDBY



Lights in red.

- 2 Press the I/ON (ON/STANDBY) button to turn on the unit.

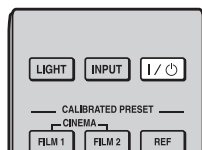

The ON/STANDBY indicator flashes in green, and then lights in green.

## ON/STANDBY



Flashes in green for a while (tens of seconds) and then lights in green.

- 3 Display a test signal for performing adjustments.

Press the PATTERN button on the remote control to display the test signal.

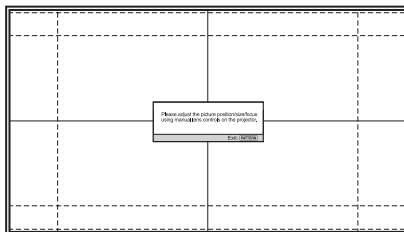
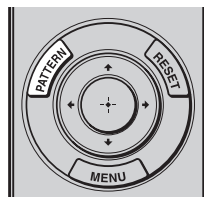

## Tip

Press the PATTERN button to clear the test signal display.

- 4** Move both lens shift dials to adjust the picture position.

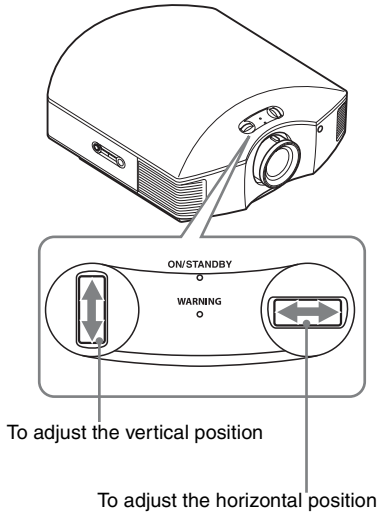



---

### To adjust the horizontal position

Turn the lens shift dial right or left.  
The picture projected on the screen moves right or left by a maximum of 25% of the screen width from the center of the lens.

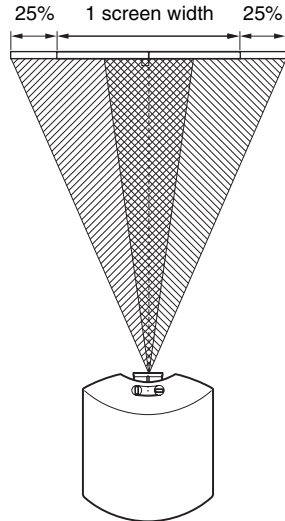
#### Top view



-  : Picture position when moving the picture to the left at maximum
-  : Picture position when moving the picture to the right at maximum



## To adjust the vertical position

Turn the lens shift dial up or down.  
The picture projected on the screen moves up or down by a maximum of 71% of the screen height from the center of the lens.

### Side view

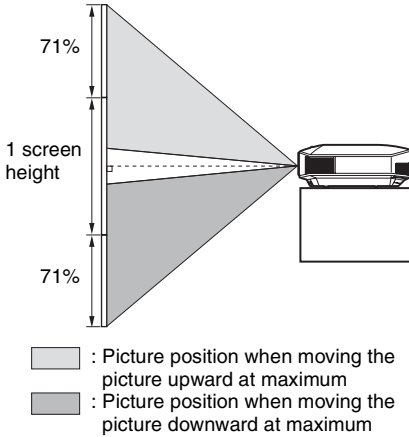

## Range of movement of the projected picture

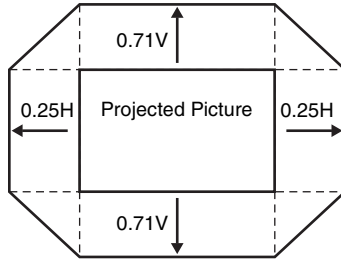

H: Width of the projected picture  
V: Height of the projected picture

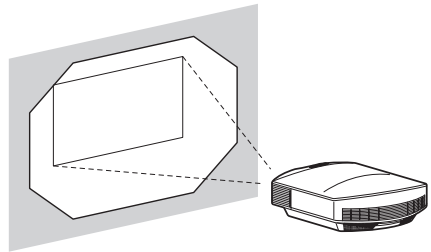

### Notes

- The range to move the picture projected on the screen can be adjusted only within the octagon area illustrated below. For details, see “Projection Distance and Lens Shift Range” (page 55).
- When you use both the horizontal and vertical lens shift features at the same time, the distance the picture projected on the screen moves differ depending on how much the lens shift is adjusted.

## 5 Adjust the picture size using the zoom lever.

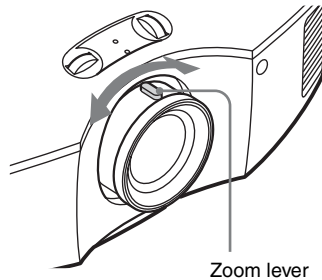

## 6 Adjust the focus using the focus ring.

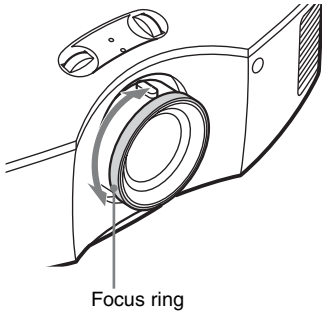

---

### To adjust the tilt of the installation surface

If the unit is installed on an uneven surface, use the front feet (adjustable) to keep the unit level.

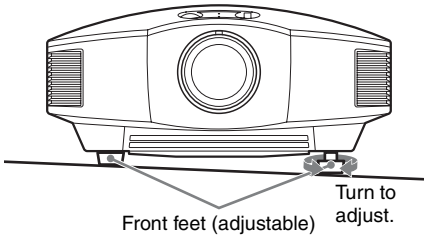

### Notes

- If the unit is tilted up or down, the projected image may be trapezoidal.
- Be careful not to catch your finger when turning the front feet (adjustable).

---

### Lens adjustment window (test pattern)

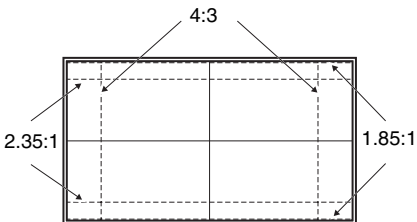

The dashed lines show the screen sizes of each aspect ratio.

# Connecting to Video Equipment or a Computer

You can enjoy high picture quality by connecting a DVD player/recorder, Blu-ray Disc player/recorder, or PlayStation® equipped with HDMI output to the HDMI input of the unit.

## When making connections, be sure to do the following:

- Turn off all equipment before making any connections.
- Use the proper cables for each connection.
- Insert the cable plugs properly; poor connection at the plugs may cause a malfunction or poor picture quality. When pulling out a cable, be sure to pull it out from the plug, not the cable itself.
- Refer to the operating instructions of the connected equipment.

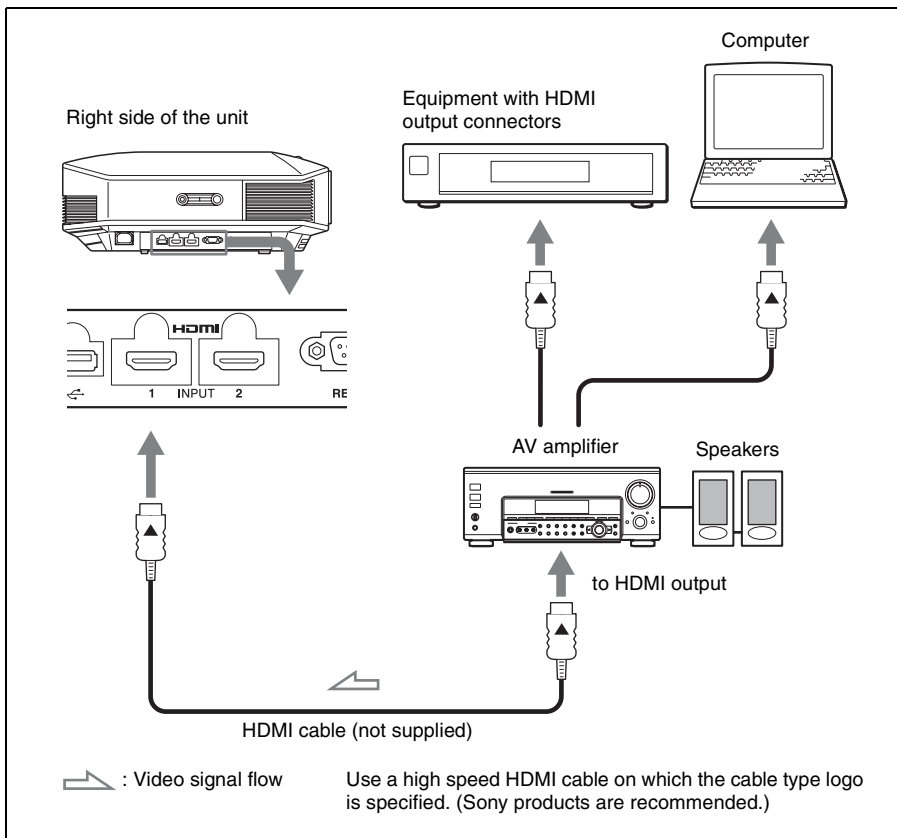

**Notes**

- Use a high-speed HDMI cable. With a standard HDMI cable, images of 1080p, DeepColor, and 3D video may not be displayed properly.
- When connecting an HDMI cable to the unit, make sure the ▼ mark on the upper part of the HDMI input of the unit and the ▲ mark on the connector of the cable is set at the same position.
- If the picture from equipment connected to the unit with an HDMI cable is not correct, check the settings of the connected equipment.
- If you set your computer, such as a notebook type, to output the signal to both computer's display and this equipment, the picture of the equipment may not appear properly. Set your computer to output the signal to only the external monitor. For details, refer to the computer's operating instructions supplied with your computer. For settings of the computer, consult with the manufacturer of the computer.

# Projecting

This section describes how to operate the unit to view the picture from the equipment connected to the unit. It also describes how to adjust the quality of the picture to suit your taste.

## Projecting the Picture

- 1 Turn on both the unit and the equipment connected to the unit.
- 2 Press INPUT to display the input palette on the screen.

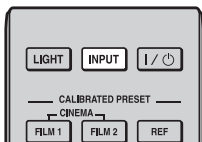

- 3 Select the equipment from which you want to display images.

Press INPUT repeatedly or press  $\uparrow/\downarrow$  /  $\odot$  (enter) to select the equipment from which to project.

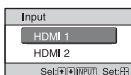

Example: To view the picture from the video equipment connected to the HDMI 1 connector of this unit.

To view the picture from	Press INPUT to display
Equipment connected to the HDMI 1 connector	HDMI 1
Equipment connected to the HDMI 2 connector	HDMI 2

### Tip

When “Status” is set to “Off” on the Setup  menu, the input palette does not appear. Press the INPUT button to switch between input terminals in sequence.

## Turning Off the Power

- 1 Press the I/ON (ON/STANDBY) button.

A message “POWER OFF?” appears on the screen.

- 2 Press the I/ON (ON/STANDBY) button again before the message disappears. The ON/STANDBY indicator flashes in green and the fan continues to run to reduce the internal heat.

The fan stops and the ON/STANDBY indicator changes from flashing green to remaining red.

The power is turned off completely, and you can disconnect the AC power cord.

### Note

Never disconnect the AC power cord while the indicator is flashing.

You can turn off the unit by holding the I/ON (ON/STANDBY) button for about 1 second, instead of performing the above steps.

---

# Watching 3D Video Images

You can enjoy powerful 3D video images, such as from 3D games and 3D Blu-ray Discs, using the optional Active 3D Glasses (TDG-BT500A).

- 1 Turn on the HDMI equipment for 3D compatibility connected to the unit, then play the 3D content.  
For details on how to play 3D content, refer to the operating instructions for the connected equipment.
- 2 Turn on the unit and project the 3D video image onto the screen.  
For details on how to project the image, see “Projecting the Picture” (page 13).
- 3 Turn on the 3D glasses, and then put them on so that they fit comfortably.  
For details on how to use the 3D glasses, see “Using the 3D Glasses” (page 14).

## Tips

- The factory default setting for “2D-3D Display Sel.” is “Auto” to allow projecting 3D video images automatically when the unit detects 3D signals.
- To convert 3D video images to 2D video images, set “2D-3D Display Sel.” to “2D” (page 29).

## Notes

- It may not be possible to display 3D video image, depending on the type of signal. Set the “2D-3D Display Sel.” to “3D,” and “3D Format” to “Side-by-Side” or “Over-Under” to suit the format of the 3D content you want to watch (page 29).
- Use the 3D glasses within the communication range (page 14).
- There are differences in perception of 3D video images among individuals.
- When the temperature of the usage environment is low, the 3D effect may be diminished.

---

## Adjusting/Setting the 3D functions

You can adjust/set the 3D functions by pressing the 3D button on the remote control or with the “3D Settings” of the Function  menu. For details, see “3D Settings” (page 29).

## Using the 3D Glasses

- 1 Turn on the 3D glasses, and register them on the unit.  
For details on how to register the 3D glasses, refer to the operating instructions supplied with the 3D glasses.
- 2 Put on the 3D glasses.
- 3 Turn toward the screen.

## Precautions for use

Misoperation may occur if:

- The viewing position is too far from the projector
- There are other communication devices, such as a wireless LAN (IEEE802.11 b/g/n) or a microwave with a bandwidth of 2.4 GHz, near the unit

---

## 3D glasses communication range

Figure below indicate the communication range of the 3D glasses. If you try to watch 3D video images from a distance greater than the communication range or install the unit outside the communication range, the 3D glasses may not be able to display the images properly. Also, the distance varies depending on the environment of the room and installation environment of the unit.

**Top or side view**

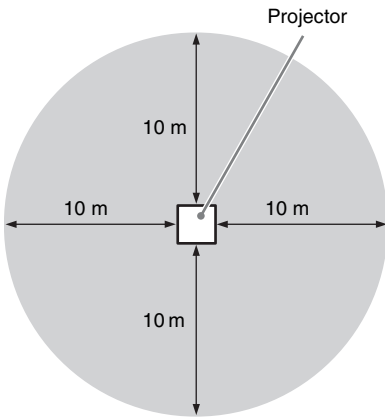

# Selecting the Aspect Ratio According to the Video Signal

You can select an aspect ratio best suited for the video signal received.

Press ASPECT.

Each time you press the button, you can select the “Aspect” setting. You can also select it using the menu (page 26).

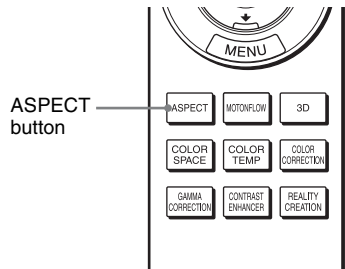

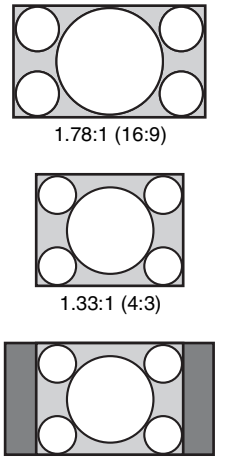
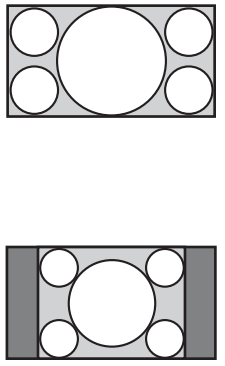
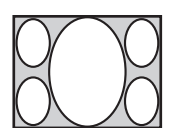
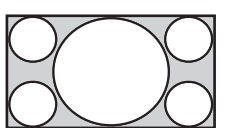
Original image	Recommended setting and resultant images
 <p>1.78:1 (16:9)</p> <p>1.33:1 (4:3)</p> <p>1.33:1 (4:3) with side panels</p>	<p>Normal</p> 
 <p>Squeezed</p>	<p>Stretch</p> 

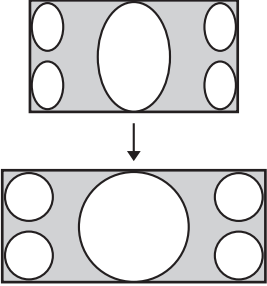
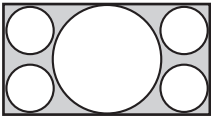
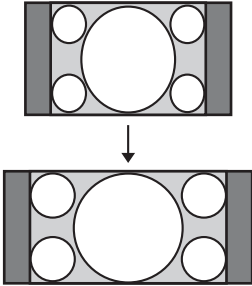

Original image	Recommended setting and resultant images
 <p data-bbox="303 288 361 309">2.35:1</p>	<p data-bbox="740 129 826 150">V Stretch</p>  <p data-bbox="639 459 928 480">When using an anamorphic lens</p>
 <p data-bbox="311 671 353 692">16:9</p>	<p data-bbox="740 512 826 533">Squeeze</p>  <p data-bbox="639 842 928 863">When using an anamorphic lens</p>

**Note**

Selectable aspect modes vary depending on the input signal (page 51).

**Notes on switching the “Aspect” setting**

- Select the aspect mode taking into account that changing the aspect ratio of the original picture will provide a different look from that of the original image.
- Note that if the unit is used for profit or for public viewing, modifying the original picture by switching the aspect may constitute an infringement of the rights of authors or producers, which are legally protected.

# Selecting the Picture Viewing Mode

You can select the picture viewing mode that best suits the type of video source or room conditions.

You can save and use different preset modes for 2D/3D respectively.

Press one of the CALIBRATED PRESET buttons.

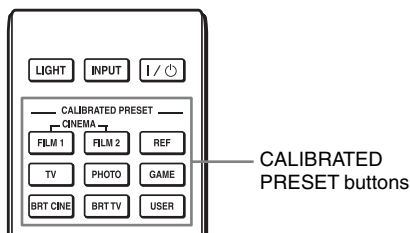

Setting items	Description
CINEMA FILM 1	Picture quality suited to reproducing the highly dynamic and clear images typical of master positive film.
CINEMA FILM 2	Picture quality suited to reproducing the rich tone and color typical of a movie theater, based on the tones changed for FILM 1.
REF	A picture quality setup suitable for when you want to reproduce faithfully the original image quality, or for enjoying image quality, without any adjustment.
TV	Picture quality suited for watching TV programs, sports, concerts, and other video images.
PHOTO	Ideal for projecting still images taken with a digital camera.
GAME	Picture quality suited to gaming, with well-modulated colors and fast response.
BRT CINE	Picture quality suited for watching movies in a bright environment, such as a living room.
BRT TV	Picture quality suited for watching TV programs, sports, concerts, and other video images in a bright environment, such as a living room.
USER	Adjusts the picture quality to suit your taste then saves the setting. The factory default setting is the same as "REF."

# Using the Menu

This section describes how to make various adjustments and settings using the menu.

## Note

The menu displays used for the explanation may be different from the actual menu display.

## Operation through the Menu

The unit is equipped with an on-screen menu for making various adjustments and settings. If you select an item name followed by an arrow (▶), the next menu window with setting items appears.

### 1 Press MENU.

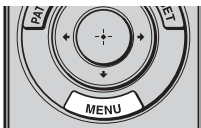

The menu window appears.

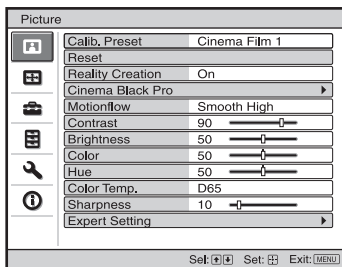

### 2 Press ↑/↓ to select a menu item, and press → or ◂.

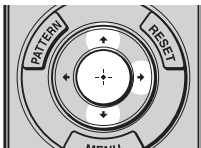

The items that can be set or adjusted with the selected menu appear. The item presently selected is shown in white.

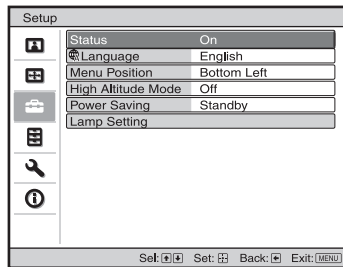

### 3 Press ↑/↓ to select an item you want to set or adjust and press → or ◂.

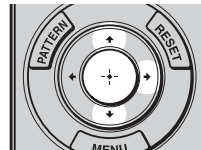

The setting items are displayed in a pop-up menu, in a setting menu, in an adjustment menu or in the next menu window.

### Pop-up menu

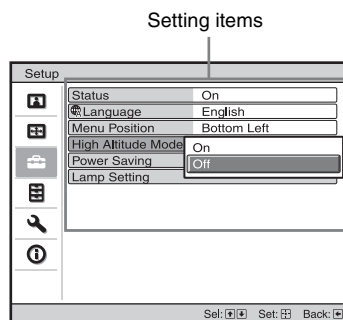

## Setting menu

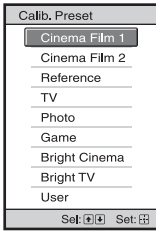

## Adjustment menu

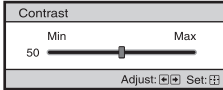

## Next menu window

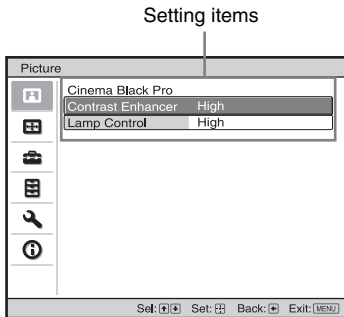

- 4 Make the setting or adjustment of an item.

### When changing the adjustment level

To increase the value, press  $\uparrow/\rightarrow$ .  
To decrease the value, press  $\downarrow/\leftarrow$ .  
Press  $\odot$  to store the setting and restore the original menu screen.

### When changing the setting

Press  $\uparrow/\downarrow$  to change the setting.  
Press  $\odot$  to restore the original screen.  
You can restore the original screen using  $\leftarrow$  depending on the selected item.

## To clear the menu

Press MENU.

## To reset the picture that has been adjusted

Select "Reset" from the Picture  $\text{Picture}$  menu.

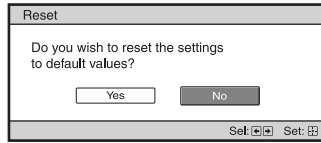

When the screen display appears, select "Yes" using  $\leftarrow$  and press  $\odot$ . All of the following settings are reset to its factory preset value:  
"Reality Creation," "Cinema Black Pro," "Motionflow," "Contrast," "Brightness," "Color," "Hue," "Color Temp.," "Sharpness," and "Expert Setting" on the Picture  $\text{Picture}$  menu

## To reset the items that have been adjusted

Select an item in the menu screen, and display the pop-up menu, the setting menu, or the adjustment menu.  
Press RESET on the remote control to reset only the selected settings to its factory preset value.

### Note

The RESET button on the remote control is available only when the adjustment menu or the setting menu is selected.

# Picture Menu

The Picture menu is used for adjusting the picture.

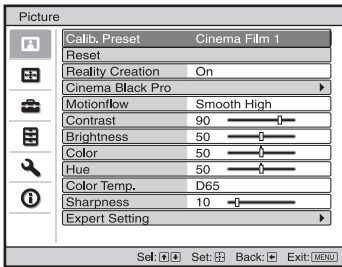

## Note

These items may not be available, depending on the type of input signal. For details, see “Input Signals and Adjustable/Setting Items” (page 49).

Item names in brackets represent those printed on the remote control.

Setting items	Description
Calib. Preset [CALIBRATED PRESET]	<p>You can select the picture viewing mode that best suits the type of video source or the environment.</p> <p>You can save and use different preset modes for 2D/3D respectively.</p> <p><b>Cinema Film 1:</b> Picture quality suited to reproducing the highly dynamic and clear images typical of master positive film.</p> <p><b>Cinema Film 2:</b> Picture quality suited to reproducing the rich tone and color typical of a movie theater, based on the tones changed for Cinema Film 1.</p> <p><b>Reference:</b> A picture quality setup suitable for when you want to reproduce faithfully the original image quality, or for enjoying image quality, without any adjustment.</p> <p><b>TV:</b> Picture quality suited for watching TV programs, sports, concerts, and other video images.</p> <p><b>Photo:</b> Ideal for projecting still images taken with a digital camera.</p> <p><b>Game:</b> Picture quality suited to gaming, with well-modulated colors and fast response.</p> <p><b>Bright Cinema:</b> Picture quality suited for watching movies in a bright environment, such as a living room.</p> <p><b>Bright TV:</b> Picture quality suited for watching TV programs, sports, concerts, and other video images in a bright environment, such as a living room.</p> <p><b>User:</b> You can adjust the picture quality to suit your taste, and save the setting. The factory default setting is the same as “Reference.”</p> <p><b>Tip</b> Any adjustments to picture quality settings are saved for each input.</p>
Reset	<p>Resets all currently selected Calib. Preset mode settings to their default values (page 20).</p> <p><b>Tip</b> Reset does not affect settings saved for items of “Color Temp.”</p>

Setting items	Description
Reality Creation [REALITY CREATION]	<p>Adjusts the detail and noise processing of images. (Super-resolution function)</p> <p><b>On:</b> Adjusts the settings of “Reality Creation.”</p> <p><b>Resolution:</b> When you increase the setting value, the texture and detail of the picture become sharper.</p> <p><b>Noise Filtering:</b> When you increase the setting value, the noise (picture roughness) becomes less prominent.</p> <p><b>Test: On/Off:</b> Changes “On” and “Off” at a certain frequency to check the effect of “Reality Creation.”</p> <p><b>Tip</b> The display position of status during the test works together with the “Menu Position” setting (page 28).</p> <p><b>Off:</b> The “Reality Creation” function is not applied.</p>
Cinema Black Pro	
Contrast Enhancer [CONTRAST ENHANCER]	<p>Corrects the level of bright and dark parts automatically to optimize contrast according to a scene.</p> <p>Increases image sharpness and makes image dynamic.</p> <p><b>High/Middle/Low:</b> You can adjust the contrast enhancer.</p> <p><b>Off:</b> The contrast enhancer function is not applied.</p>
Lamp Control	<p>Switches the lamp output.</p> <p><b>High:</b> Increases the brightness, and projects brighter images.</p> <p><b>Low:</b> Decreases the brightness, and enhances blacks by minimizing brightness.</p> <p><b>Tip</b> Setting “Low” reduces fan noise, while also reducing energy consumption for longer lamp life.</p>
Motionflow [MOTIONFLOW]	<p><b>Impulse:</b> Reproduces original picture quality. Provides cinema-like picture, which may flicker.</p> <p><b>Combination:</b> Reduces motion blur while maintaining brightness for high-speed picture content.</p> <p><b>Smooth High:</b> Provides smoother picture movement; especially effective for film-based content.</p> <p><b>Smooth Low:</b> Provides smoother picture movement for standard use.</p> <p><b>True Cinema:</b> Images, such as a movie created in 24 frames per second, are reproduced at the original framerate.</p> <p><b>Off:</b> The “Motionflow” function is not applied.</p> <p><b>Tips</b></p> <ul style="list-style-type: none"> <li>• Select “Off” if the selected “Smooth High,” “Smooth Low,” “Impulse,” “Combination,” or “True Cinema” results in a distorted picture.</li> <li>• Depending on the picture content, you may not see the effect visually even if you have changed the settings.</li> </ul>
Contrast [CONTRAST]	<p>Adjusts the contrast.</p> <p>Higher values increase the sharpness in images, while lower values decrease the sharpness.</p> <p>You can make adjustments by pressing the CONTRAST +/- on the remote control.</p>
Brightness [BRIGHTNESS]	<p>Adjusts the brightness of the picture.</p> <p>The higher the setting, the brighter the picture. The lower the setting, the darker the picture.</p> <p>You can make adjustments by pressing the BRIGHTNESS +/- on the remote control.</p>

Setting items	Description
Color	Adjusts the color density. The higher the setting, the greater the intensity. The lower the setting, the lower the intensity.
Hue	Adjusts the color tone. The higher the setting, the more greenish the picture becomes. The lower the setting, the more reddish the picture becomes.
Color Temp. [COLOR TEMP]	Adjusts the color temperature. <b>D93:</b> Equivalent to 9,300 K color temperature normally used in TVs. Gives white colors a blue tint. <b>D75:</b> Equivalent to 7,500 K color temperature used as an ancillary standard illuminant. Gives a neutral tint between “D93” and “D65.” <b>D65:</b> Equivalent to 6,500 K color temperature used as a standard illuminant. Gives white colors a red tint. <b>D55:</b> Equivalent to 5,500 K color temperature used as an ancillary standard illuminant. Gives white colors an even redder tint. <b>Custom 5:</b> Setting that prioritizes brightness.  <b>Tip</b> You can adjust each item to a color temperature according to your preference.
Sharpness [SHARPNESS]	Sharpens the outline of the picture, or reduces the noise. The higher the setting, the sharper the picture. The lower the setting, the softer the picture, thus reducing the noise. You can make adjustments by pressing the SHARPNESS +/- on the remote control.
Expert Setting	
NR (Noise Reduction)	Reduces the roughness or noise of the picture. <b>Auto:</b> Detects the noise level to reduce the roughness or noise of the picture automatically. <b>High/Middle/Low:</b> Select a setting according to the roughness or noise of the input signal source. <b>Off:</b> The NR (noise reduction) function is not applied.  <b>Tip</b> The noise level may not be detected accurately with “Auto” depending on the input signal source. If the picture is unacceptable with “Auto,” select a setting from among “High;” “Middle;” “Low” or “Off.”
MPEG NR (MPEG Noise Reduction)	Reduces block noise and mosquito noise, in particular in digital signals. <b>Auto:</b> Detects the noise level to reduce the block noise and mosquito noise of the picture automatically. <b>High/Middle/Low:</b> Select a setting according to the block noise and mosquito noise of the input signal source. <b>Off:</b> The MPEG NR (MPEG noise reduction) function is not applied.  <b>Tip</b> The noise level may not be detected accurately with “Auto” depending on the input signal source. If the picture is unacceptable with “Auto,” select a setting from among “High;” “Middle;” “Low” or “Off.”
Smooth Gradation	Smooths the gradation of the flat parts of images. <b>High/Middle/Low:</b> You can adjust the smooth gradation effect. <b>Off:</b> The smooth gradation function is not applied.

Setting items	Description
Film Mode	<p>According to the film source you have selected, make a setting for playback.</p> <p><b>Auto:</b> Suitable for reproducing the original picture movement. Normally, set this to "Auto."</p> <p><b>Off:</b> Plays back the picture in progressive format without detecting video signals automatically.</p>
Gamma Correction [GAMMA CORRECTION]	<p>Adjusts the response characteristics of the tone of the picture. Select a favorite tone from 6 options.</p> <p><b>2.0:</b> Bright Produces a brighter picture overall.</p> <p><b>2.2</b> ↓</p> <p><b>2.4:</b> Dark Produces a darker picture overall.</p> <p><b>Gamma 8:</b> Increases the sharpness in images. Select this when you watch in a bright environment, such as a living room.</p> <p><b>Gamma 9:</b> Produces a brighter picture than Gamma 8.</p> <p><b>Gamma 10:</b> Increases the sharpness in images. Select this when you watch TV programs, etc., in a bright environment, such as a living room.</p> <p><b>Off:</b> The "Gamma Correction" function is not applied.</p>
Color Correction [COLOR CORRECTION]	<p><b>On:</b> Adjusts Hue, Saturation or Brightness of the selected colors. Repeat steps ① and ② described below to specify the target color.</p> <p>① Press ↑/↓ to select "Color Select," then press ←/→ to select the color you want to adjust among "Red," "Yellow," "Green," "Cyan," "Blue" and "Magenta."</p> <div data-bbox="530 671 801 799" data-label="Image"> </div> <p>② Press ↑/↓ to select "Hue," "Saturation" or "Brightness," then adjust them to suit your taste using ←/→ while watching the projected picture.</p> <p><b>Off:</b> The "Color Correction" effect is not applied.</p>
Clear White	<p>Emphasizes vivid whites.</p> <p><b>High/Low:</b> You can adjust the "Clear White" effect.</p> <p><b>Off:</b> The "Clear White" effect is not applied.</p>
x.v.Color	<p>Set this item when connecting the unit with equipment that supports x.v.Color and playing back an x.v.Color video signal.</p> <p><b>On:</b> You can play back an x.v.Color video signal.</p> <p><b>Off:</b> The "x.v.Color" function is not applied.</p> <p>For details on x.v.Color, see "About the x.v.Color" (page 40).</p> <p><b>Tip</b> Setting x.v.Color to "On" disables gamma adjustment.</p>

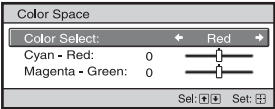

Setting items	Description
Color Space [COLOR SPACE]	<p>Converts the color space.</p> <p><b>BT.709:</b> An ITU-R BT.709 color space, which is used for high-definition television broadcast or Blu-ray Disc. The color space is equivalent to sRGB.</p> <p><b>Color Space 1:</b> The color space suited for watching TV programs and video images, such as sport, concerts, etc.</p> <p><b>Color Space 2:</b> The color space suited for watching TV programs, sport, concerts, and other video images in a bright environment, such as a living room.</p> <p><b>Color Space 3:</b> The color space suited for watching movies in a bright environment, such as a living room.</p> 
	<p><b>Tip</b> You can adjust each item to a color space according to your preference.</p>
Input Lag Reduction	<p>Reduces the delay of the display for a video.</p> <p><b>On:</b> Reproduces a smooth fast-moving video image with a reduced sense of afterimage.</p> <p><b>Off:</b> Turns the Input Lag Reduction function off.</p> <p><b>Tip</b> When “Input Lag Reduction” is set to “On,” Motionflow, NR, and MPEG NR cannot be set.</p>

# Screen Menu

You can set the picture size, aspect mode, etc.

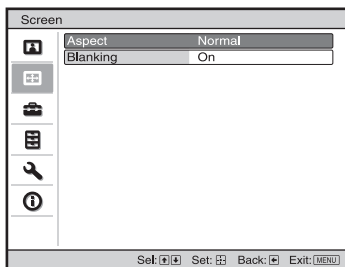

## Note

These items may not be available, depending on the type of input signal. For details, see “Input Signals and Adjustable/Setting Items” (page 49).

Item names in brackets represent those printed on the remote control.

Setting items	Description
Aspect [ASPECT]	<p>You can set the aspect ratio of the picture to be displayed for the current input signal (page 16).</p> <p>You can set the function only when a video signal is input.</p> <p><b>Normal:</b> Input video is displayed in its original aspect ratio, enlarged to fill the screen. This mode is suitable for viewing 1.78:1 (16:9) and 1.33:1 (4:3) video.</p> <p><b>V Stretch:</b> This is the most suitable mode for using a 2.35:1 screen to view 2.35:1 video with a commercially available anamorphic lens.</p> <p><b>Squeeze:</b> With this setting, 1.78:1 (16:9) and 1.33:1 (4:3) video will be displayed in their correct aspect ratios when you use a commercially available anamorphic lens.</p> <p><b>Stretch:</b> Displays video that has been squeezed to 1.33:1 (4:3) as 1.78:1 (16:9) aspect ratio.</p> <p><b>Tips</b></p> <ul style="list-style-type: none"><li>• Selectable aspect modes vary depending on the input signal (page 51).</li><li>• The aspect cannot be selected for an input signal from a computer (pages 47, 48, 51).</li></ul>

---

**Setting items****Description**

---

Blanking

This feature allows you to adjust the displayable region within the four directions of the screen.

**On:** Select the edge to adjust by highlighting Left, Right, Top, or Bottom using the **↑/↓** buttons.

Adjust the amount of blanking using the **←/→** buttons.

Blanking	
Left:	2
Right:	3
Top:	2
Bottom:	3

Set: [ ] Adjust: [ ] Set: [ ]

**Off:** Turns off the Blanking function.

**Tip**

Depending on the aspect ratio setting, right/left blanking may not be available.

---

# Setup Menu

The Setup menu is used to change the factory preset settings, etc.

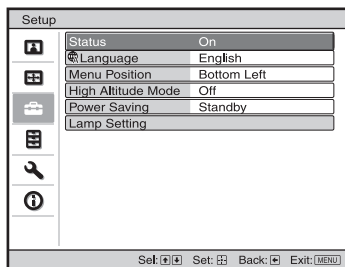

Setting items	Description
Status	Sets whether or not the on-screen display is displayed. Set to “Off” to turn off the on-screen displays except for certain menus, message when turning off the power, and warning messages.
Language	Selects the language used in the menu and on-screen displays.
Menu Position	You can change the position to display the menu on the screen. <b>Bottom Left:</b> Displays the menu on the bottom left area of the screen. <b>Center:</b> Displays the menu on the center of the screen.
High Altitude Mode	Sets the unit to operate at the prevailing atmospheric pressure. <b>On:</b> Use this setting when using the unit at an altitude of 1,500 m (approx. 4,900 ft) or higher. <b>Off:</b> Use this setting when using the unit at normal altitudes.  <b>Tip</b> When this item is set to “On,” the fan noise becomes slightly louder since the fan speed increases.
Power Saving	Sets the power saving mode. <b>Standby:</b> If no signal is input for 10 minutes, power is turned off automatically and the projector goes into standby mode. <b>Off:</b> Disables the power saving function.
Lamp Setting	When replacing the lamps, set the desired lamp setting (page 41).

# Function Menu

The Function menu is used for changing the settings of the various functions of the unit.

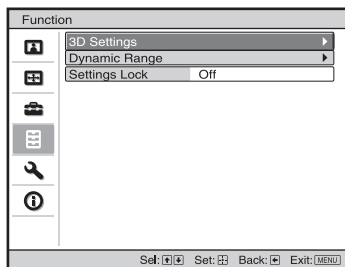

Setting items	Description
3D Settings	You can change the settings of the 3D function.
2D-3D Display Sel.	<p>For Switching the video images to “2D” or “3D.”</p> <p><b>Auto:</b> Displays 3D video images when HDMI signals with 3D information* are input. Displays 2D video images when other signals are input.</p> <p><b>3D:</b> Displays 3D video images according to the 3D system selected in “3D Format.” However, when HDMI signals with 3D information are input to the unit, displays 3D video images according to the 3D system of those HDMI signals.</p> <p><b>2D:</b> Displays 2D video images.</p> <p>* The 3D information is additional information to discriminate 3D. Some HDMI signals have additional information to discriminate 3D and some HDMI signals have none.</p> <p><b>3D Format:</b> Set the 3D system when the input HDMI signals do not include 3D information.</p> <p><b>Simulated 3D:</b> Converts 2D video images to 3D video images. The setting can be made only for input the HD signals. The simulated 3D feature may have limited effect, depending on the video source. There are differences in perception of 3D video images among individuals.</p> <p><b>Side-by-Side:</b> Select this to display 3D images as two similar images, side-by-side.</p> <p><b>Over-Under:</b> Select this to display 3D images as two similar images, one above the other.</p> <p><b>Tips</b></p> <ul style="list-style-type: none"><li>• “2D-3D Display Sel.” cannot be set to “3D” for some video sources. For available 3D signals, see “Compatible 3D Signals” (page 50).</li><li>• The simulated 3D feature may have limited effect, depending on the screen size (100 to 120 inches recommended) and the video source.</li><li>• The menu display has a ghost while a 3D video image is displayed and is best viewed with the 3D glasses.</li></ul>

Setting items	Description
3D Glasses Brightness	For adjusting the brightness of the picture when watching 3D video images. You can select the brightness from among “High,” “Medium,” and “Low.”
3D Depth Adjust	For adjusting the depth of the 3D video images on the screen. The setting can be made only when a 3D Format other than “Simulated 3D” is selected.  Depth    -2    -1    0    +1    +2 Front ←    Normal    → Depth  We recommend that “3D Depth Adjust” be set to “0.” The 3D video images may be difficult to perceive, depending on the setting of “3D Depth Adjust.”
Simulated 3D Effect	For adjusting the 3D effect when 2D content is converted to 3D video images. You can select the effect from among “High,” “Middle,” and “Low.”  <b>Tip</b> There are differences in perception of 3D video images converted by the simulated 3D function among individuals.
Dynamic Range	Sets the video input level for HDMI 1 and HDMI 2 connectors. <b>Auto:</b> Sets the video input level automatically. <b>Limited:</b> The video input level is set for signals of 16-235. <b>Full:</b> The video input level is set for signals of 0-255.  <b>Note</b> If the video output setting of the connected HDMI device is not set correctly, light and dark parts of the video may appear too light or too dark.
Settings Lock	Locks menu item settings to prevent operational error (page 31). <b>Off:</b> Cancels the Settings Lock. <b>Level A:</b> Group 1 items (below) are not displayed on the menu, and are not available. <b>Level B:</b> Group 1 and Group 2 items (below) are not displayed on the menus, and are not available.

## Items Locked by Settings Lock

### Group 1

---

#### Picture menu

---

Reset  
Reality Creation  
Contrast Enhancer  
Lamp Control  
Motionflow  
Contrast  
Brightness  
Color  
Hue  
Color Temp.  
Sharpness  
NR  
MPEG NR  
Smooth Gradation  
Film Mode  
Gamma Correction  
Color Correction  
Clear White  
x.v.Color  
Color Space

---

### Group 2

---

#### Setup menu

---

Status  
Language  
Menu Position  
High Altitude Mode  
Lamp Setting

---

#### Function menu

---

Dynamic Range

---

#### Installation menu

---

Image Flip  
Panel Alignment

---

---

# 🔧 Installation Menu

The Installation menu is used for changing the installation settings.

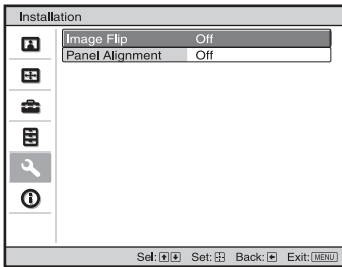

---

Setting items	Description
Image Flip	Flips the picture on the screen horizontally and/or vertically. <b>HV:</b> Flips the picture horizontally and vertically. <b>H:</b> Flips the picture horizontally. <b>V:</b> Flips the picture vertically. <b>Off:</b> The picture does not flip. Use this item for installation for the backside projection or ceiling installation.

---



**Setting items****Description**

## Panel Alignment

This feature allows you to adjust the gaps in the color of characters or the picture on the screen.

**On:** Adjusts the gaps in the colors selecting “Adjust Color” or “Adjust Item.”

**Adjust Item:** Selects how to make adjustments from below.

**Shift:** Shifts the whole picture and makes adjustments.

**Zone:** Selects the desired range and makes adjustments.

**Adjust Color:** Assigns the desired color to adjust the gaps in color. Select “R” (Red) or “B” (Blue) to make adjustments based on “G” (Green).

**Pattern Color:** Select “R/G” (Red and Green) or “R/G/B” (White, all colors) when “Adjust Color” is “R” (Red). Select “B/G” (Blue and Green) or “R/G/B” (White, all colors) when the “Adjust Color” is “B” (Blue).

**Adjust:** The shift adjustment and zone adjustment of the color selected in “Adjust Color” can be made with ←/→, ↑/↓ buttons.

When “Shift” is selected: Assign the settings of the horizontal direction (H) with ←/→ buttons and the vertical direction (V) with ↑/↓ buttons on the shift adjustment screen.

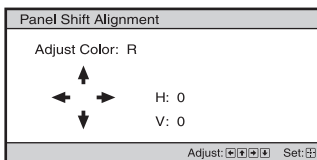

When “Zone” is selected: Select the position to adjust with ←/→ buttons for the horizontal position (H position) and ↑/↓ buttons for the vertical position (V position), then press (↕).

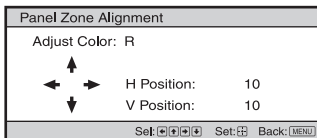

Set the amount to adjust with ←/→ buttons for the horizontal direction (H direction) and with ↑/↓ buttons for the vertical direction (V direction). You can select the position to adjust again by pressing (↕).

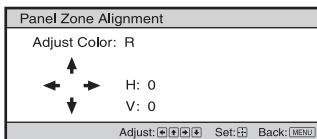

**Reset:** Returns to the factory settings.

**Off:** The optimized data has been preset.

**Note**

Depending on the adjustments made above, colors may become uneven or the resolution may change.

# Information Menu

The Information menu displays the model name, serial number, input signal type, software version and the cumulated hours of usage of the lamp.

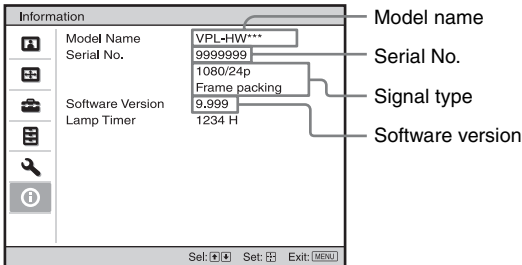

Items	Description
Model Name	Displays the model name
Serial No.	Displays the serial number.
Signal type	Displays the type of the input signal. When input signals with 3D information are input, the type of input signals and the 3D format are displayed.
Software Version	Displays the software version.
Lamp Timer	Indicates how long the lamp has been turned on (total usage).

## Note

You cannot adjust or change the displays listed above.

## About the Preset Memory

This unit has default image data to adjust preset data for input signals appropriately according to the signals shown in “Preset Signals” (page 47) (the preset memory). When the preset signal is input, the unit automatically detects the signal type and recalls the data for the signal from the preset memory to adjust it to an optimum picture. The signal type is displayed in the Information  menu.

## Note

Depending on the computer input signal, parts of screen may be hidden or displayed incorrectly.



## Troubleshooting

If the unit appears to be operating erratically, try to diagnose and correct the problem using the following instructions. If the problem persists, consult with qualified Sony personnel.

### Power

Symptom	Cause and Remedy	Page
The power is not turned on.	The power may not turn on if you turn the power off with I/⏻ (ON/STANDBY) button and turn it on again in a short time. After about 1 minute, turn the power on.	–
	Close the lamp cover securely, then tighten the screws securely.	42
	Close the filter holder securely.	43
	Check warning indicators.	38
The power is suddenly turned off.	Check that “Power Saving” in the Setup  menu is set to “Standby.”	28
	Set “Power Saving” to “Off.”	28

### Picture

Symptom	Cause and Remedy	Page
No picture.	Check that the connecting cable is connected to the external equipment properly.	11
	Select the input source correctly using the INPUT button.	13
	Check that the computer signal is set for output to an external monitor. If the notebook computer, etc., signal is output to its display and an external monitor, the external monitor’s image may not be displayed correctly. Set your computer to output the signal to only an external monitor.	–
The picture has ghosts.	Video images are displayed in 3D. Watch the 3D video images using the 3D glasses, or set “2D-3D Display Sel.” to “2D.”	14, 29
Bright or dark area of the video appears too bright or too dark.	This symptom may occur when signal level other than those of HDMI standard is input. Switch the output level of the connected equipment, or switch the Dynamic Range on the Function  menu of the unit.	30
The picture is too dark.	Adjust “Contrast” or “Brightness” on the Picture  menu properly.	22
The picture is not clear.	Adjust the focus.	10
	Condensation has accumulated on the lens. Leave the unit for about 2 hours with the power on.	–
The color of characters or the picture is not appropriate.	Select the desired color registration in “Panel Alignment” of the Installation  menu.	33

Symptom	Cause and Remedy	Page
Image is left on the screen. (image retention)	When high contrast non-moving images are displayed for a long period of time, there may be some image retention on the screen. This is only a temporary condition. Turning off the power for a while will eliminate the retained image.	–

### On-screen display

Symptom	Cause and Remedy	Page
On-screen display does not appear.	Set “Status” on the Setup  menu to “On.”	28
	Check if the ON/STANDBY indicator should light in green. When the ON/STANDBY indicator blinks in green, the unit is starting up. Wait until it stops blinking and remains lit in green.	7
The model name does not disappear from the screen.	The display mode of the unit may be set at the time of purchase. Consult with your local dealer or qualified Sony personnel.	–

### Remote control

Symptom	Cause and Remedy	Page
The remote control does not work.	Batteries could be weak. Replace them with new batteries.	–
	Insert the batteries with the correct polarities.	–
	If there is a fluorescent lamp near the remote control detector, the unit may work improperly or inadvertently.	–
	Confirm the position of the remote control detector on the unit.	3

### 3D video images

Symptom	Cause and Remedy	Page
The video image does not seem like 3D video images.	Check if the 3D glasses are turned on.	14
	Make sure that the battery in the 3D glasses could be weak or is sufficiently charged.	–
	Set “2D-3D Display Sel.” to “Auto” or “3D.”	29
	Check if the input signals are compatible 3D signals.	50
	The 3D signals may not be input depending on the specifications of the connected AV selector/AV amplifier/external equipment. If the 3D signal is not input, confirm the specifications and/or settings of the AV selector/AV amplifier/external equipment.	–
	When the viewing position is too far from the unit, the 3D glasses may not be able to display the images properly.	14
	The screen size is not appropriate. Set the zooming magnification to low or watch the image from farther away from the screen.	55
	For details, see “Precautions for use” of “Using the 3D Glasses.”	14

## Others

Symptom	Cause and Remedy	Page
The fan is noisy.	Check the setting of “High Altitude Mode” on the Setup  menu.	28
	Make sure that the room temperature is not too high.	–
	Check the installation requirements of the unit. Fan speed increases to maintain the product reliability of the projector’s components in a room, where the temperature is higher than normal. The fan noise becomes slightly louder. The approximate normal temperature is 25°C (77°F).	–
The lens shift cannot be adjusted.	The lens shift cannot be adjusted over the range of movement. Adjust the lens shift within the range of movement.	9, 55

# Warning Indicators

The ON/STANDBY or WARNING indicator lights up or flashes if there is any trouble with your projector.

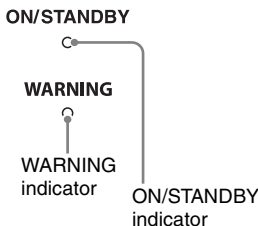

Flashing/Lighting indicators	The number of flashes	Cause and Remedy
ON/STANDBY ○	Twice	Close the lamp cover securely, then tighten the screws securely (page 42). Close the filter holder securely (page 43).
WARNING ☀ (Flashes in red)	Three times	The temperature of lamp is unusually high. Turn off the power and wait for the lamp to cool, then turn on the power again. If the symptom persists, the lamp may be at the end of its service life. In this case, replace the lamp with a new one (page 41).
ON/STANDBY ☀ (Flashes in red)	Twice	The internal temperature is unusually high. Check to ensure that if nothing is blocking the ventilation holes or whether or not the unit is being used at high altitudes.
WARNING ☀ (Flashes in red) Both indicators flash	Three times	The fan is broken. Consult with qualified Sony personnel.

## Note

When a warning indicator other than the above starts flashing, and the symptom persists even after carrying out the above methods, consult with qualified Sony personnel.

# Message Lists

## Warning messages

Symptom	Cause and Remedy	Page
High temp.! Lamp off in 1 min.	Turn off the power.	–
	Check to ensure that nothing is blocking the ventilation holes.	3, 4
Frequency is out of range!	Frequency is out of range. Input a signal that is within the acceptable frequency range of the unit.	47
Please replace the Lamp/Filter.	It is time to replace the lamp. Replace the lamp. Also, replace the air filter too. Restart cleaning the ventilation holes (intake). If this message appears again after you replace the lamp and filter, the lamp replacement process is not complete. Check the lamp replacement process.	41
<b>Note</b>		
To clear this message, press any button either on the remote control or the control panel of the unit once.		
Please clean the filter.	It is time to clean the air filter. Clean the air filter.	44
<b>Note</b>		
To clear this message, press any button either on the remote control or the control panel of the unit once.		
Please clean the filter.	It is time to clean the air filter. Clean the air filter.	44
Have you finished? Yes/No	If you cleaned the air filter, select “Yes.” If you did not clean the air filter, select “No.”	
Projector temperature is high. High Altitude Mode should be “On” if projector is being used at high altitude.	Check to ensure that nothing is blocking the ventilation holes.	3, 4
	When using the unit at high altitude, set “High Altitude Mode” to “On.”	28
<b>Note</b>		
When temperature inside the unit remains high, “High Altitude Mode” is switched to “On” in 1 minute, then the fan speed increases.		
Power Saving Mode is set. Projector will automatically enter Standby Mode in 1 minute.	“Power Saving” is set to “Standby.”	28
<b>Note</b>		
If no signal is input, the power turns off after 1 minute, and the projector goes into standby mode.		

## Caution messages

Symptom	Cause and Remedy	Page
	No signal is input in the selected input. Check connections.	11
Not applicable!	Press the appropriate button. The operation to be activated by the button is currently prohibited.	–
Settings Lock enabled.	“Settings Lock” is set to “Level A” or “Level B.”	30

---

### Updating the Software

You can download files to update the software of the unit. Copy the downloaded files to your USB memory, insert the USB memory to the USB terminal of the unit, then perform the update.

To use the features updated, insert a USB memory device into a PC connected to the internet.

Download the update files from the following Sony website:

<http://www.pro.sony.eu/>

The website also explains how to install the update.

#### Note

Some USB memories may not be supported for use. For details, refer to the website above.

---

### About the x.v.Color

- “x.v.Color” is a promotion name given to the products that have the capability to realize a wide color space based on the xvYCC specifications and is a trademark of Sony Corporation.
- xvYCC is an international standard of the technical specifications of the extended-gamut color space for video signals. The color gamut of xvYCC is wider than the one of sRGB that is used with the current television system.

---

### About the simulated 3D feature

- Use the simulated 3D function taking into account that the picture will provide a different look from the original images, because this function converts the video images.
- Note that if the unit is used for profit or for public viewing, displaying 2D video images as 3D video images by converting to the simulated 3D may constitute an infringement of the rights of authors or producers, which are legally protected.



# Replacing the Lamp and the Air Filter and Cleaning the Ventilation Holes (intake)

## Tools you need to get started:

- Projector Lamp LMP-H210 (optional)
- Standard Phillips screwdriver
- Cloth (for scratch protection)

The lamp used for the light source has a certain lifespan. When the lamp dims, the color balance of the picture becomes strange, or “Please replace the Lamp/Filter.” appears on the screen, the lamp may be exhausted. Replace the lamp with a new one without delay.

Use an LMP-H210 Projector Lamp as the replacement lamp.

The air filter is supplied with the LMP-H210 Projector Lamp. When you replace the lamp, it is also time to replace the air filter.

Whenever you replace the lamp, be sure to replace the air filter with a new one. Also clean the ventilation holes (intake).

## Tip

The lifespan of the lamp used for the light source changes depending on the installation environment or use conditions. You can use the lamp longer by avoiding turning the lamp off until several minutes pass after turning the lamp on.

## Caution

- The lamp remains hot after the unit is turned off with the I/⏻ (ON/STANDBY) button. If you touch the lamp, you may burn your fingers. When you replace the lamp, wait for at least 1 hour for the lamp to cool.
- Do not touch the surface of the lamp. If you touch it, wipe off the fingerprints with a soft cloth.
- Pay special attention to replacing the lamp when the unit is installed on the ceiling.
- When removing the lamp unit, make sure it remains horizontal, then pull straight up.

Do not tilt the lamp unit. If you pull out the lamp unit while tilted and if the lamp breaks, the pieces may scatter, causing injury.

- When you remove the air filter, be careful not to let any dust fall into the projector.
- Replacing the air filter is crucial to maintain the good performance of the projector or to prevent malfunction to it. When a warning message for replacing the air filter appears, replace the air filter immediately.

## Notes

- Be sure to use an LMP-H210 Projector Lamp for replacement. If you use lamps other than the LMP-H210, the unit may malfunction.
- Be sure to turn off the unit and unplug the power cord before replacing the lamp, then check the ON/STANDBY indicator has already been turned off.

**1** Turn off the projector and unplug the AC power cord.

**2** When setting the projector on a flat surface such as a desk etc., put a cloth to prevent the surface from being scratched. Reverse the projector as illustrated, then place it on the cloth.

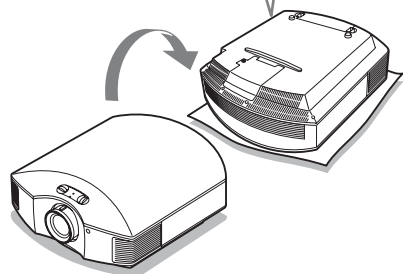
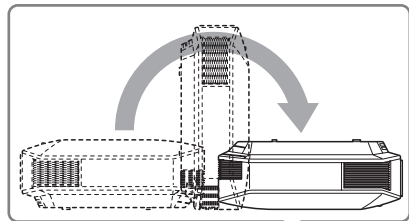

## Notes

- When the lamp is damaged the broken pieces of the lamp may become

scattered, if you do not reverse the projector. This may cause injury.

- Be sure that the projector is placed on a stable surface.

- 3** Loosen the screw on the lamp cover with a Philips screwdriver, and then open the lamp cover.

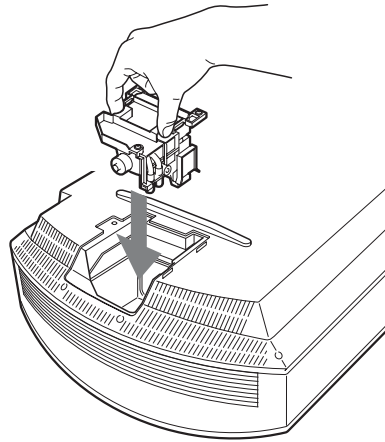
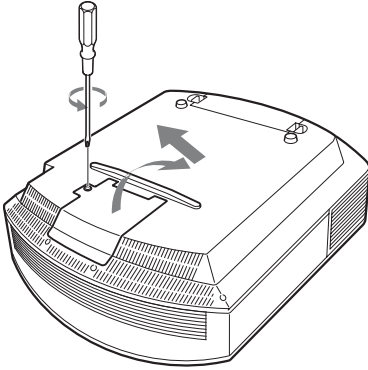

**Note**

Be careful not to touch the optical block inside the unit.

- 4** Loosen the 3 screws on the lamp with the Phillips screwdriver. Hold up the handle, then pull the lamp straight out.

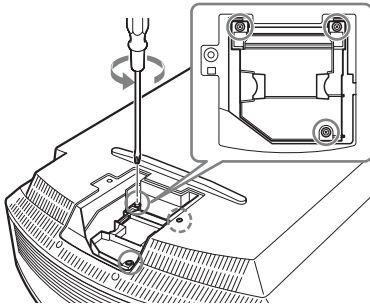

- 6** Close the lamp cover, then tighten the screws.

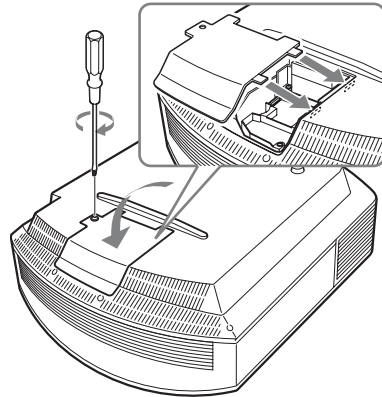

- 5** Hold the handle of the new lamp and push it in securely until it reaches the end, and then tighten the 3 screws.

**7** Remove the filter holder.

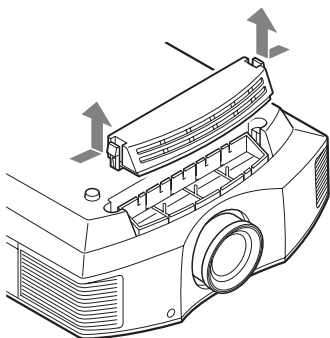

**8** Remove the air filter.

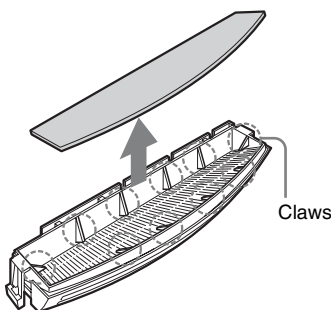

**9** Attach the new air filter so that it fits into each claws (10 positions) on the filter holder.

**Note**

Attach the air filter aligning it with the shape of the filter holder. Also, do not touch the fan after removing the air filter that is set deep inside the projector.

**10** Attach the filter holder.

**Note**

The projector will not turn on unless the filter holder is securely closed.

**11** Wipe dust off the ventilation holes (intake) with a soft cloth.

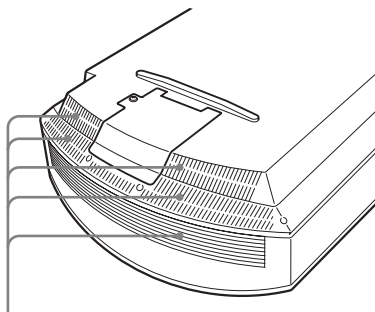

Ventilation holes (intake)

**12** Place the unit back on its original position.

**13** Turn on the unit, then select the lamp setting item on the Setup  menu. The menu screen below will be appeared.

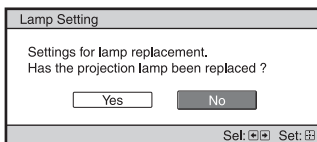

**Tip**

If “Settings Lock” is set to “Level B,” set to “Off” once (page 30).

**14** Select “Yes.”

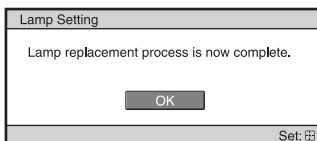

**Caution**

Do not put your hands into the lamp replacement slot, and do not allow any liquid or other objects into the slot to avoid electrical shock or fire.

**Notes**

- The unit will not turn on unless the lamp is securely installed in place.

- The unit will not turn on unless the lamp cover are securely closed.
- To clear a message displayed on the screen, press any button either on the remote control or the control panel of the unit once.

**Note**

The lamp contains mercury. The disposal rules for used fluorescent tubes depend on where you live. Follow the waste disposal policy in your area.

**Disposal of the used lamp****For the customers in the U.S.A. and Canada**

**(Hg)** Lamp contains mercury. Dispose according to applicable local, state/province and federal laws.

For additional information, see [www.sony.com/mercury](http://www.sony.com/mercury)

---

## Cleaning the Air Filter

When “Please clean the filter.” appears on the screen, you should clean the air filter. The air filter should be cleaned every 1,500 hours. This value varies depending on the environment or how the projector is used. 1,500 hours are approximate.

After washing the air filter with a mild detergent solution, dry it in a shaded place.

**Notes**

- When you clean the air filter, make sure you do not damage it.  
For details on how to attach and remove the air filter, see “Replacing the Lamp and the Air Filter and Cleaning the Ventilation Holes (intake)” Steps 7 to 10 (page 43).
- When you remove the air filter, be careful not to let any dust fall into the projector.
- Cleaning the air filter is crucial to maintain the good performance of the projector or to prevent malfunction to it. When a warning message for cleaning the air filter appears, clean the air filter immediately.

---

## Fitting the Lens Cap

When fitting the lens cap onto the lens, position the lens cap so that the concave on the side of the lens cap will fit the zoom lever, as shown in the illustration.

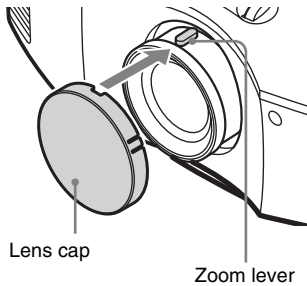

---

## Cleaning

### Cleaning the lens

The lens surface is especially treated to reduce reflection of light.

As incorrect maintenance may impair the performance of the projector, take care with respect to the following:

- Wipe the lens gently with a soft cloth such as a cleaning cloth or glass cleaning cloth.
- Stubborn stains may be removed with a soft cloth such as a cleaning cloth or glass cleaning cloth lightly dampened with water.
- Never use solvent such as alcohol, benzene or thinner, or acid, alkaline or abrasive detergent, or chemical cleaning cloth, as they will damage the lens surface.

### Cleaning the cabinet

- To remove dust from the cabinet, wipe gently with a soft cloth. If dust is persistent, wipe with a soft cloth slightly moistened with a diluted mild detergent solution.
- Never use any type of abrasive pad, alkaline/acid cleaner, scouring powder, or volatile solvent, such as alcohol, benzene, thinner or insecticide.
- Clean the unit with a cleaning cloth. Wiping with a dirty cloth may scratch the unit.
- Using such materials or maintaining prolonged contact with rubber or vinyl materials may result in damage to the screen surface and cabinet material.

# Specifications

Item	Description
Display system	SXRD panel, 1 lens, projection system
Display device	Size of effective display area
	Number of pixels
Projection lens	1.6 times zoom lens (manual) f = 18.7 mm to 29.7 mm F2.52 to F3.02
Light source	Ultra High Pressure Lamp 215 W type
Screen size	40 inches to 300 inches (1,016 mm to 7,620 mm) (measured diagonally)
Acceptable video signals	480/60p, 576/50p, 720/60p, 720/50p, 1080/60i, 1080/50i, 1080/60p, 1080/50p, 1080/24p
Acceptable computer signals	fH: 19 kHz to 72 kHz fV: 48 Hz to 92 Hz Maximum resolution 1,920 × 1,080 For details, see “Preset Signals” (page 47).
HDMI (2 inputs), HDCP compliant	Digital RGB/Y Pb/Cb Pr/Cr
Other inputs/ outputs	REMOTE
	IR IN
	USB
Outside dimensions (w/h/d)	407.4 mm × 179.2 mm × 463.9 mm (16 <sup>1</sup> / <sub>8</sub> × 7 <sup>1</sup> / <sub>8</sub> × 18 <sup>3</sup> / <sub>8</sub> inches)
Mass	Approx. 9 kg (20 lb)
Power requirements	AC 100 V to 240 V, 3.1 A to 1.3 A, 50/60 Hz
Power consumption	Max. 310 W
Power consumption (Standby)	0.4 W
Operating temperature	5°C to 35°C (41°F to 95°F)
Operating humidity	35% to 85% (no condensation)
Storage temperature	-20°C to +60°C (-4°F to +140°F)
Storage humidity	10% to 90%
Supplied accessories	See “Checking the Supplied Accessories” in the supplied Quick Reference Manual.
Optional accessories	<b>Projector Lamp:</b> LMP-H210 (for replacement) <b>Projector Suspension Support:</b> PSS-H10 <b>Active 3D Glasses:</b> TDG-BT500A*

\* The 3D Glasses communicate with the projector via Bluetooth technology to display 3D signals.

## Notes

- The values for mass and dimensions are approximate.
- Not all optional accessories are available in all countries and area. Please check with your local Sony Authorized Dealer.
- Information on accessories in this manual is current as of April 2016.

Design and specifications of this unit and its optional accessories are subject to change without notice.

## Preset Signals

The following table shows the signals and video formats which you can project using this unit. When a signal other than the preset signal shown below is input, the picture may not be displayed properly.

Preset memory no.	Preset signal (resolution)		fH (kHz)	fV (Hz)	Sync
5	480/60p	480/60p (Progressive NTSC) (720 × 480p)	31.470	60.000	–
6	576/50p	576/50p (Progressive PAL) (720 × 576p)	31.250	50.000	–
7	1080/60i	1080/60i (1920 × 1080i)	33.750	60.000	–
8	1080/50i	1080/50i (1920 × 1080i)	28.130	50.000	–
10	720/60p	720/60p (1280 × 720p)	45.000	60.000	–
11	720/50p	720/50p (1280 × 720p)	37.500	50.000	–
12	1080/60p	1080/60p (1920 × 1080p)	67.500	60.000	–
13	1080/50p	1080/50p (1920 × 1080p)	56.260	50.000	–
14	1080/24p	1080/24p (1920 × 1080p)	26.973	23.976	–
18	720/60p (Frame packing)	720/60p (1280 × 720p)	90.000	60.000	–
19	720/50p (Frame packing)	720/50p (1280 × 720p)	75.000	50.000	–
20	1080/24p (Frame packing)	1080/24p (1920 × 1080p)	53.946	23.976	–
26	640 × 480	VESA 60	31.469	59.940	H-NEG, V-NEG
32	800 × 600	VESA 60	37.879	60.317	H-POS, V-POS
37	1024 × 768	VESA 60	48.363	60.004	H-NEG, V-NEG
45	1280 × 960	VESA 60	60.000	60.000	H-POS, V-POS
47	1280 × 1024	VESA 60	63.974	60.013	H-POS, V-POS
50	1400 × 1050	SXGA+	65.317	59.978	H-NEG, V-POS
55	1280 × 768	1280 × 768/60	47.776	59.87	H-NEG, V-POS
71	1920 × 1080/60i (Frame packing)	1080/60i (1920 × 1080i)	67.500	60.000	–

Preset memory no.	Preset signal (resolution)		fH (kHz)	fV (Hz)	Sync
72	1920 × 1080/50i (Frame packing)	1080/50i (1920 × 1080i)	56.250	50.000	–

## Preset memory numbers for each input signal

### Digital signal

Signal	Preset memory number
Component signal (HDMI 1, 2 connectors)	5 to 8, 10 to 14, 18 to 20, 71, 72
Video GBR signal (HDMI 1, 2 connectors)	5 to 8, 10 to 14, 18 to 20, 71, 72
Computer signal (HDMI 1, 2 connectors)	10 to 13*, 26, 32, 37, 45, 47, 50, 55

\* Some digital signals input from computers may be displayed as preset memory number of Component or Video GBR signal.



## Input Signals and Adjustable/Setting Items

The items in the menus available to adjust differ depending on the input signal. The following tables indicate them. The items that cannot be adjusted/set are not displayed in the menu.

### Picture menu

Item	Input signal		
	Component signal	Video GBR signal	Computer signal
Reality Creation	●	●	–
Contrast Enhancer	●	●	–
Lamp Control	●	●	●
Motionflow* <sup>1</sup>	● (excluding preset memory number 19)	● (excluding preset memory number 19)	–
Contrast	●	●	●
Brightness	●	●	●
Color	●	●	–
Hue	●	●	–
Color Temp.	●	●	●
Sharpness	●	●	–
NR	●	●	–
MPEG NR	●	●	●
Smooth Gradation	●	●	–
Film Mode	● (excluding preset memory number 14)	● (excluding preset memory number 14)	–
Gamma Correction* <sup>2</sup>	●	●	●
Color Correction	●	●	●
Clear White	●	●	●
x.v.Color	●	–	–
Color Space	●	●	●

●: Adjustable/can be set

–: Not adjustable/cannot be set

\*1: For further details, refer to the tables in “Motionflow” (page 52).

\*2: The setting can be made only when “x.v.Color” is set to “Off”.

### Screen menu

Item	Input signal		
	Component signal	Video GBR signal	Computer signal
Aspect	●	●	●* <sup>1</sup>

●: Adjustable/can be set

–: Not adjustable/cannot be set

\*1: If the input signal is from a computer, the setting cannot be made when the aspect ratio is 16:9 or wider (fixed at “Normal”).

**Note**

When connecting a cable such as an HDMI cable, etc., check the type of the signal in the Information **i** menu (page 34) and “Digital signal” (page 48), and check items that are adjustable/can be set.

## Compatible 3D Signals

This unit accepts the following types of 3D signals.

Resolution	3D signal format
720/60p, 720/50p	Side-by-Side format
	Over-Under format*
	Frame packing*
1080/60i, 1080/50i	Side-by-Side format
	Frame packing
1080/24p	Side-by-Side format
	Over-Under format*
	Frame packing*
1080/60p, 1080/50p	Side-by-Side format
	Over-Under format

\*: Mandatory 3D format of the HDMI standards.

## 3D Signals and Adjustable/Setting Items

Some items on the menus may not be available to adjust/set, depending on the 3D signals. The items that cannot be adjusted are not displayed on the menu. The following tables indicate those items.

Item	3D signals			
	720/60p, 720/50p	1080/60i, 1080/50i	1080/24p	1080/60p, 1080/50p
Reality Creation	●	●	●	●
Lamp Control	●	●	●	●
Motionflow* <sup>1</sup>	●	●	●	●
NR	–	–	–	–
MPEG NR	–	–	–	–
Smooth Gradation	–	–	–	–
Film Mode	–	●	–	–
x.v.Color	●	●	●	●
Aspect* <sup>2</sup>	●	●	●	●

●: Adjustable/can be set

–: Not adjustable/cannot be set

\*1: The item is not available for Frame Packing/Over-Under on 720/60p, or Over-Under on 1080/60p.

\*2: For further details, refer to the tables in “Aspect Mode” (page 51).

When the unit is set to convert 2D video images to 3D video images, some items on the menus may be not available to adjust/set, depending on the “3D Format” settings on the Function  menu. The items that cannot be adjusted are not displayed on the menu. The following tables indicate these items.

Item	3D signals		
	Over-Under	Side-by-Side	Simulated 3D
Reality Creation	●	●	●
Lamp Control	●	●	●
Motionflow* <sup>1</sup>	●	●	●
NR	–	–	●
MPEG NR	–	–	●
Smooth Gradation	–	–	●
Film Mode* <sup>2</sup>	–	●	●
x.v.Color	●	●	●
Aspect* <sup>3</sup>	●	●	●

●: Adjustable/can be set

–: Not adjustable/cannot be set

\*1: The item is not available for Over-Under on 720/60p, or Over-Under on 1080/60p.

\*2: The item is not available for 720/60p, or Over-Under on 1080/60p.

\*3: For further details, refer to the tables in “Aspect Mode” (page 51).

## Aspect Mode

Selectable items vary depending on the type of input signal or 3D format.

For details, see the tables below. Items that cannot be selected are not displayed in the menu.

### 2D

Acceptable signals	1920 × 1080 1280 × 720	720 × 480 720 × 576	Others
Preset memory number (page 47)	7, 8, 10 to 14	5, 6	26, 32, 37, 45, 47, 50, 55
Normal	●	●	●* <sup>1</sup>
V Stretch	●	●	–
Squeeze	●	●	–
Stretch	–	●	–

\*1: Not displayed in the menu as fixed at Normal.

### 3D

Acceptable signals	1920 × 1080, 1280 × 720			
3D format	Side-by-Side	Over-Under	Frame packing	Simulated 3D
Preset memory number (page 47)	7, 8, 10 to 14	10 to 14	18 to 20, 71, 72	7, 8, 10 to 14
Normal	●	●	●	●
V Stretch	●	●	●	●
Squeeze	●	●	●	●
Stretch	–	–	–	–

### Motionflow

Selectable items vary depending on the type of input signal or 3D format.  
For details, see the tables below. Items that cannot be selected are not displayed in the menu.

### 2D

Acceptable signals	1920 × 1080 1280 × 720 720 × 480 720 × 576	Others
Preset memory number (page 47)	5 to 8, 10 to 13	26, 32, 37, 45, 47, 50, 55
Impulse	●	–
Combination	●	–
Smooth High	●	–
Smooth Low	●	–
True Cinema	●	–

### 3D

Acceptable signals	1920 × 1080, 1280 × 720							
3D format	Frame packing			Over-Under			Side-by-Side	Simulated 3D
Preset memory number (page 47)	18	19	20, 71, 72	10, 12	11, 13	14	7, 8, 10 to 14	7, 8, 10 to 14
Impulse	–	–	–	–	–	–	–	–
Combination	–	–	–	–	–	–	–	–
Smooth High	–	–	●	–	–	●	●	●
Smooth Low	–	●	●	–	●	●	●	●
True Cinema	–	–	–	–	–	–	–	–

## Storage Conditions of Adjustable/Setting Items

Each adjustable/setting item is individually stored for each input connector. For further details, see the tables below.

### Preset memory numbers for each input signal

Input	Preset memory numbers
HDMI 1 (2D)	5 to 8, 10 to 14, 26, 32, 37, 45, 47, 50, 55
HDMI 2 (2D)	
HDMI 1 (3D)	7, 8, 10 to 14, 18 to 20, 71, 72
HDMI 2 (3D)	

### Picture menu

Item	Storage conditions
Calib. Preset	For each input connector and Calib. Preset
Reset	
Reality Creation	
Contrast Enhancer	
Lamp Control	
Motionflow	
Contrast	
Brightness	
Color	
Hue	
Color Temp.	
D93-D55	
Custom 5	
Gain R	
Gain G	
Gain B	
Bias R	
Bias G	
Bias B	

Item	Storage conditions
Sharpness	For each input connector and Calib. Preset
NR	
MPEG NR	
Smooth Gradation	
Film Mode	
Gamma Correction	
Color Correction	
Clear White	
x.v.Color	
Color Space	

# Projection Distance and Lens Shift Range

The projection distance refers to the distance between the front of the lens and the projected surface.

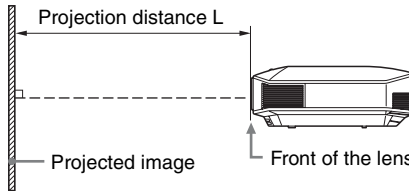

The lens shift range represents the distance in percent (%) by which the lens can be shifted from the center of the projected image. The lens shift range is regarded as 0% when the point **(A)** in the illustration (point where a line drawn from the center of the lens and the projected image cross at right angles) is aligned with the center of the projected image and full width or full height of the projected image is regarded as 100%.

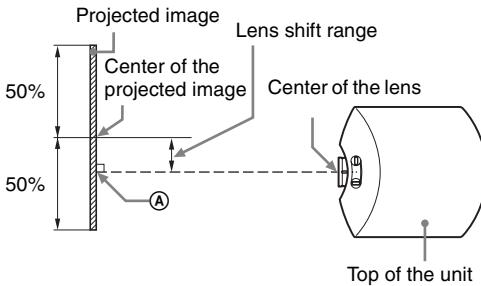
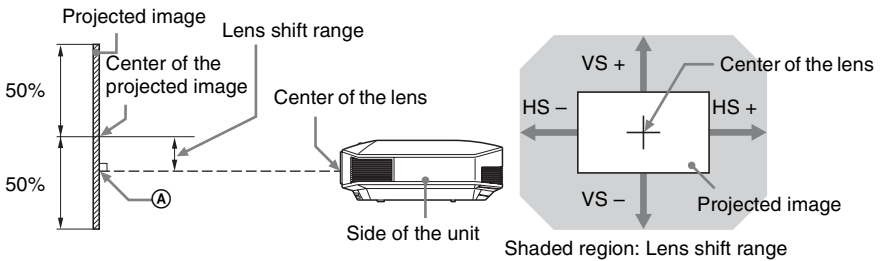

- VS +: Vertical lens shift range (up) [%]
- VS -: Vertical lens shift range (down) [%]
- HS +: Horizontal lens shift range (right) [%]
- HS -: Horizontal lens shift range (left) [%]

## When projecting in 1.78:1 (16:9) format

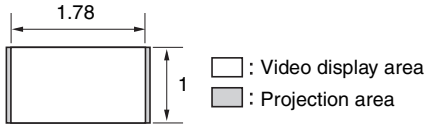

### Projection distance

Unit: m (inches)

Projection image size		Projection distance L
Diagonal	Width × Height	
80" (2.03 m)	1.77 × 1.00 (70 × 39)	2.40 – 3.83 (95 – 150)
100" (2.54 m)	2.21 × 1.25 (87 × 49)	3.00 – 4.79 (119 – 188)
120" (3.05 m)	2.66 × 1.49 (105 × 59)	3.61 – 5.76 (142 – 226)
150" (3.81 m)	3.32 × 1.87 (131 × 74)	4.52 – 7.20 (178 – 283)
200" (5.08 m)	4.43 × 2.49 (174 × 98)	6.04 – 9.61 (238 – 378)

### Projection distance formula

D: Projected image size (Diagonal)

Unit: m (inches)

Projection distance L (minimal length)	Projection distance L (maximal length)
$L = 0.030349 \times D - 0.0354$ $(L = 1.194837 \times D - 1.3915)$	$L = 0.048191 \times D - 0.0212$ $(L = 1.897302 \times D - 0.8329)$

### Lens shift range

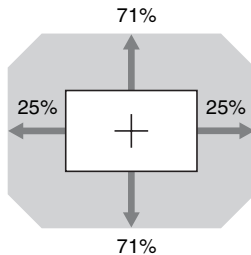

$$\begin{aligned}
 VS + &= VS - = 71 - 2.840 \times (HS + \text{ or } HS -) [\%] \\
 HS + &= HS - = 25 - 0.352 \times (VS + \text{ or } VS -) [\%]
 \end{aligned}$$



# Dimensions

## Front

Unit: mm (inches)

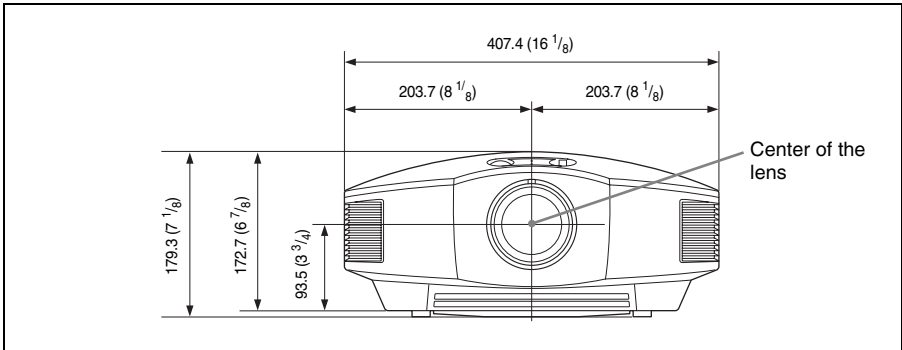

## Bottom

Unit: mm (inches)

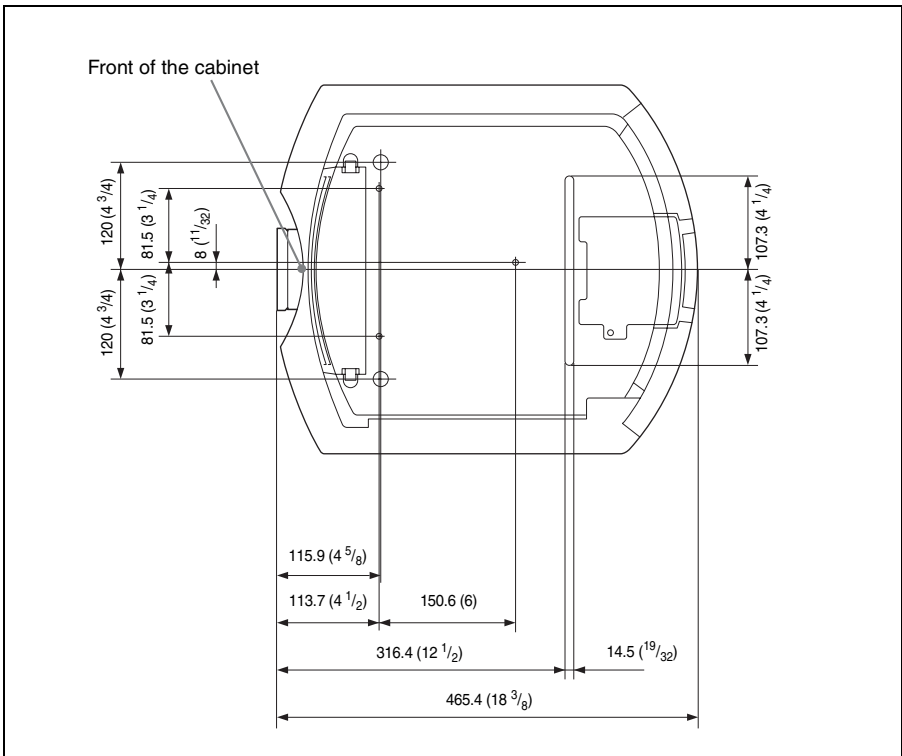

# Attaching the PSS-H10 projector suspension support

## Front view

Unit: mm (inches)

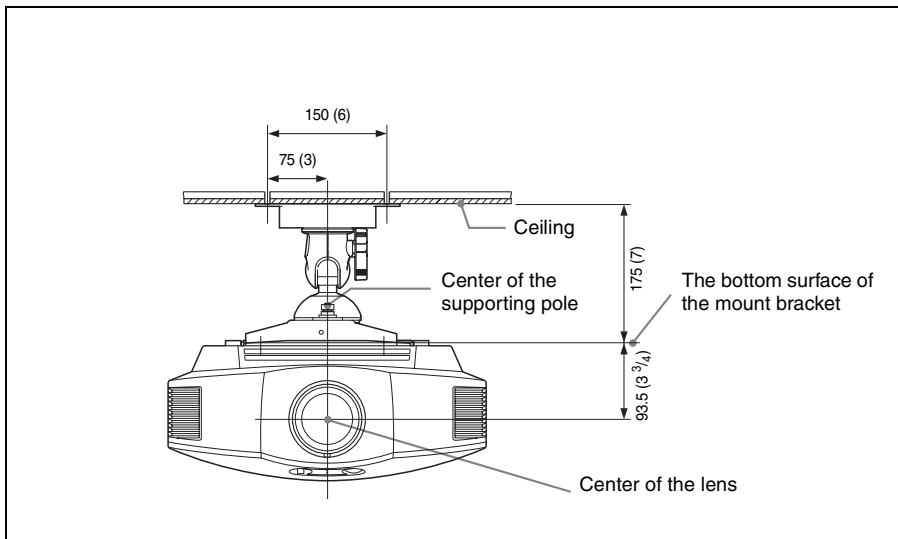

## Side view

Unit: mm (inches)

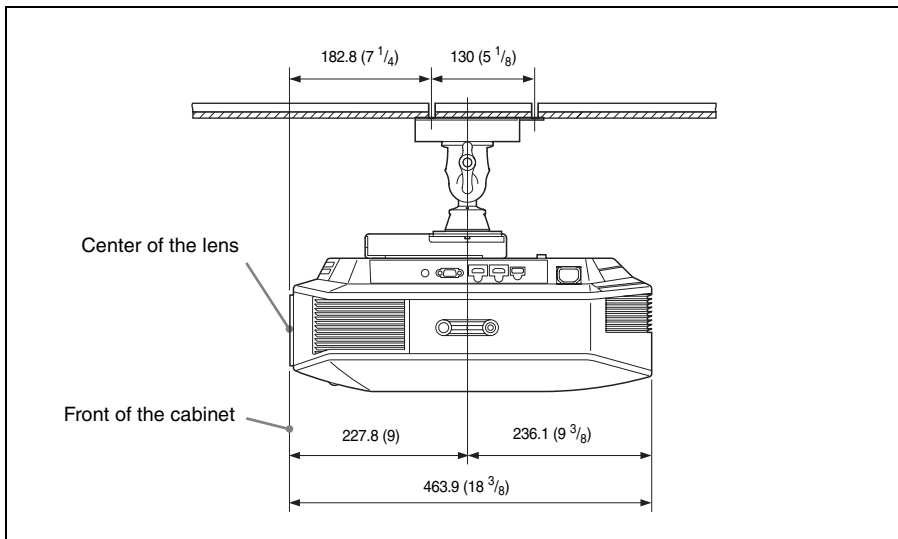

**Top view**

Unit: mm (inches)

